



DIGITAL Semiconductor 21143 PCI/CardBus 10/100-Mb/s Ethernet LAN Controller

Hardware Reference Manual

Order Number: EC-QWC4F-TE

Revision/Update Information: This is a revised document. It supersedes the *DIGITAL Semiconductor 21143 PCI/CardBus 10/100-Mb/s Ethernet LAN Controller Hardware Reference Manual*, EC-QWC4E-TE.

Hardware Version: This document describes the 21143-PB, 21143-TB, 21143-PC, 21143-TC, 21143-PD, and the 21143-TD.

Digital Equipment Corporation
Maynard, Massachusetts

<http://www.digital.com/semiconductor>

Important Notice

As of May 17, 1998, Digital Equipment Corporation's StrongARM, PCI Bridge, and Networking component businesses, along with the chip fabrication facility in Hudson, Massachusetts, were acquired by Intel Corporation and transferred to Intel Massachusetts, Inc. As a result of this transaction, certain references to web sites, telephone numbers, and fax numbers have changed in the documentation. This information will be updated in the next version of this manual. Copies of documents that have an ordering number and are referenced in this document, or other Intel literature may be obtained by calling **1-800-332-2717** or by visiting Intel's website for developers at:

<http://developer.intel.com>

The Intel Massachusetts Customer Technology Center continues to service your StrongARM Product, Bridge Product, and Network Product technical inquiries. Please use the following information lines for support:

For documentation and general information:

Intel Massachusetts Information Line

United States:	1-800-332-2717
Outside United States:	1-303-675-2148
Electronic mail address:	techdoc@intel.com

For technical support:

Intel Massachusetts Customer Technology Center

Phone (U.S. and international):	1-978-568-7474
Fax:	1-978-568-6698
Electronic mail address:	techsup@intel.com

December 1997

While DIGITAL believes the information included in this publication is correct as of the date of publication, it is subject to change without notice.

Please read the Support, Products, and Documentation section in this document to determine how to obtain current product update and errata information.

Digital Equipment Corporation makes no representations that the use of its products in the manner described in this publication will not infringe on existing or future patent rights, nor do the descriptions contained in this publication imply the granting of licenses to make, use, or sell equipment or software in accordance with the description.

©Digital Equipment Corporation 1997. All rights reserved.
Printed in U.S.A.

DIGITAL, DIGITAL Semiconductor, SecureON, and the DIGITAL logo are trademarks of Digital Equipment Corporation.

DIGITAL Semiconductor is a Digital Equipment Corporation business.

CardBus is a trademark of Personal Computer Memory Card International Association.

IEEE is a registered trademark of The Institute of Electrical and Electronics Engineers, Inc.

Magic Packet is a trademark of Advanced Micro Devices, Inc.

Microsoft is a registered trademark of Microsoft Corporation.

MicroWire is a registered trademark of BankAmerica Corporation.

All other trademarks and registered trademarks are the property of their respective owners.

Contents

Preface

1 Introduction

1.1	General Description	1–1
1.2	Features	1–3
1.3	Microarchitecture	1–6

2 Signal Descriptions

2.1	21143 Pinout	2–1
2.2	Signal Descriptions	2–3

3 Registers

3.1	Configuration Operation	3–3
3.1.1	Configuration Register Mapping	3–4
3.1.2	Standard Configuration Registers	3–6
3.1.2.1	Configuration ID Register (CFID–Offset 00H)	3–6
3.1.2.2	Command and Status Configuration Register (CFCS–Offset 04H)	3–7
3.1.2.3	Configuration Revision Register (CFRV–Offset 08H)	3–10
3.1.2.4	Configuration Latency Timer Register (CFLT–Offset 0CH)	3–11
3.1.2.5	Configuration Base I/O Address Register (CBIO–Offset 10H)	3–12
3.1.2.6	Configuration Base Memory Address Register (CBMA–Offset 14H)	3–13
3.1.2.7	Configuration Card Information Structure Register (CCIS–Offset 28H)	3–14
3.1.2.8	Subsystem ID Register (CSID–Offset 2CH)	3–16
3.1.2.9	Expansion ROM Base Address Register (CBER–Offset 30H)	3–17
3.1.2.10	Capabilities Pointer (CCAP–Offset 34H)	3–18
3.1.2.11	Configuration Interrupt Register (CFIT–Offset 3CH)	3–19
3.1.2.12	Capability ID Register (CCID–Offset DCH)	3–20
3.1.2.13	Power-Management Control and Status Register (CPMC–Offset E0H)	3–23

3.1.3	21143-Specific Configuration Registers	3–24
3.1.3.1	Configuration Device and Driver Area Register (CFDD–Offset 40H) . . .	3–24
3.1.3.2	Configuration Wake-Up-LAN IEEE Address Registers (CWUA0–Offset 44H, CWUA1–Offset 48H)	3–26
3.1.3.3	SecureON™ Password Registers (SOP0–Offset 4CH, SOP1–Offset 50H)	3–28
3.1.3.4	Configuration Wake-Up Command Register (CWUC–Offset 54H)	3–30
3.2	CSR Operation	3–33
3.2.1	Control and Status Register Mapping	3–34
3.2.2	Host CSRs	3–35
3.2.2.1	Bus Mode Register (CSR0–Offset 00H)	3–35
3.2.2.2	Transmit Poll Demand Register (CSR1–Offset 08H)	3–39
3.2.2.3	Wake-Up Frame Filter Register (CSR1-PM–Offset 08H)	3–40
3.2.2.4	Wake-Up Frame Filter Register	3–41
3.2.2.4.1	Filter i Byte Mask	3–41
3.2.2.4.2	Filter i Command	3–42
3.2.2.4.3	Filter i Offset	3–44
3.2.2.4.4	Filter i CRC-16	3–44
3.2.2.5	Receive Poll Demand Register (CSR2–Offset 10H)	3–46
3.2.2.6	Wake-Up Events Control and Status (CSR2-PM–Offset 10H)	3–47
3.2.2.7	Descriptor List Base Address Registers (CSR3–Offset 18H and CSR4–Offset 20H)	3–49
3.2.2.8	Status Register (CSR5–Offset 28H)	3–51
3.2.2.9	Operation Mode Register (CSR6–Offset 30H)	3–58
3.2.2.10	Interrupt Enable Register (CSR7–Offset 38H)	3–67
3.2.2.11	Missed Frames and Overflow Counter Register (CSR8–Offset 40H) . . .	3–71
3.2.2.12	Boot ROM, Serial ROM, and MII Management Register (CSR9–Offset 48H)	3–72
3.2.2.13	Boot ROM Programming Address Register (CSR10–Offset 50H)	3–75
3.2.2.14	General-Purpose Timer and Interrupt Mitigation Control Register (CSR11–Offset 58H)	3–76
3.2.2.15	SIA Status Register (CSR12–Offset 60H)	3–78
3.2.2.16	SIA Connectivity Register (CSR13–Offset 68H)	3–81
3.2.2.17	SIA Transmit and Receive Register (CSR14–Offset 70H)	3–82
3.2.2.18	SIA and General-Purpose Port Register (CSR15–Offset 78H)	3–87
3.2.2.19	SIA and MII Operating Modes	3–92
3.3	CardBus Status Changed Registers	3–96
3.3.1	Function Event Register (FER–Offset 80H)	3–96
3.3.2	Function Event Mask Register (FEMR–Offset 84H)	3–98
3.3.3	Function Present State Register (FPSR–Offset 88H)	3–99
3.3.4	Function Force Event Register (FFER–Offset 8CH)	3–100

4 Host Communication

4.1	Data Communication	4–1
4.2	Descriptor Lists and Data Buffers	4–1

4.2.1	Receive Descriptors	4-3
4.2.1.1	Receive Descriptor 0 (RDES0)	4-5
4.2.1.2	Receive Descriptor 1 (RDES1)	4-9
4.2.1.3	Receive Descriptor 2 (RDES2)	4-10
4.2.1.4	Receive Descriptor 3 (RDES3)	4-11
4.2.1.5	Receive Descriptor Status Validity	4-12
4.2.2	Transmit Descriptors	4-12
4.2.2.1	Transmit Descriptor 0 (TDES0)	4-13
4.2.2.2	Transmit Descriptor 1 (TDES1)	4-16
4.2.2.3	Transmit Descriptor 2 (TDES2)	4-19
4.2.2.4	Transmit Descriptor 3 (TDES3)	4-19
4.2.2.5	Transmit Descriptor Status Validity	4-20
4.2.3	Setup Frame	4-20
4.2.3.1	First Setup Frame	4-21
4.2.3.2	Subsequent Setup Frames	4-21
4.2.3.3	Perfect Filtering Setup Frame Buffer	4-21
4.2.3.4	Imperfect Filtering Setup Frame Buffer	4-23
4.3	Functional Description	4-25
4.3.1	Reset Commands	4-25
4.3.2	DMA Arbitration Scheme	4-26
4.3.3	Interrupts	4-27
4.3.3.1	Receive and Transmit Interrupt Mitigation	4-29
4.3.4	Initialization Procedure	4-30
4.3.5	Receive Process	4-31
4.3.5.1	Descriptor Acquisition	4-31
4.3.5.2	Frame Processing	4-31
4.3.5.3	Receive Process Suspended	4-32
4.3.5.4	Receive Process State Transitions	4-33
4.3.6	Transmit Process	4-34
4.3.6.1	Frame Processing	4-34
4.3.6.2	Transmit Polling Suspended	4-35
4.3.6.3	Transmit Process State Transitions	4-36
4.3.7	Card Information Structure	4-37

5 Host Bus Operation

5.1	Overview	5-1
5.2	Bus Commands	5-2
5.3	Bus Slave Operation	5-2
5.3.1	Slave Read Cycle (I/O or Memory Target)	5-3
5.3.2	Slave Write Cycle (I/O or Memory Target)	5-4
5.3.3	Configuration Read and Write Cycles	5-5
5.4	Bus Master Operation	5-6
5.4.1	Bus Arbitration	5-7
5.4.2	Memory Read Cycle	5-8

5.4.3	Memory Write Cycle	5-9
5.5	Termination Cycles	5-11
5.5.1	Slave-Initiated Termination	5-11
5.5.1.1	Disconnect Termination	5-11
5.5.1.2	Retry Termination	5-12
5.5.2	Master-Initiated Termination	5-13
5.5.2.1	21143-Initiated Termination	5-13
5.5.2.2	Memory-Controller-Initiated Termination	5-15
5.6	Parity	5-18
5.7	Parking	5-19
5.8	PCI/CardBus Clock Control through Clkrun	5-19

6 Network Interface Operation

6.1	MII/SYM Port.	6-1
6.1.1	100BASE-T Terminology	6-1
6.1.2	Interface Description	6-2
6.1.2.1	Signal Standards	6-2
6.1.2.2	Operating Modes	6-4
6.2	10BASE-T and AUI Functions	6-5
6.2.1	Receivers and Drivers	6-6
6.2.2	Manchester Decoder	6-6
6.2.3	Manchester Encoder	6-6
6.2.4	Oscillator Circuitry	6-6
6.2.5	Smart Squelch	6-7
6.2.6	Autopolarity Detector	6-7
6.2.7	Network Port Autosensing	6-8
6.2.8	10BASE-T Link Integrity Test	6-9
6.3	Media Access Control Operation	6-9
6.3.1	MAC Frame Format	6-9
6.3.1.1	Ethernet and IEEE 802.3 Frames	6-10
6.3.1.2	Ethernet Frame Format Description	6-10
6.3.2	Ethernet Reception Addressing	6-12
6.3.3	Detailed Transmit Operation	6-13
6.3.3.1	Transmit Initiation	6-13
6.3.3.2	Frame Encapsulation	6-13
6.3.3.3	Initial Deferral	6-14
6.3.3.4	Collision	6-14
6.3.3.5	Terminating Transmission	6-15
6.3.3.6	Transmit Parameter Values	6-16
6.3.4	Detailed Receive Operation	6-16
6.3.4.1	Receive Initiation	6-16
6.3.4.2	Preamble Processing	6-16
6.3.4.2.1	MII/SYM, 10BASE-T, or AUI Mode Preambles	6-17
6.3.4.2.2	100BASE-TX or 100BASE-FX Mode Preambles	6-18

6.3.4.3	Address Matching	6-18
6.3.4.4	Frame Decapsulation	6-18
6.3.4.5	Terminating Reception	6-19
6.3.4.6	Frame Reception Status	6-19
6.4	Loopback Operations	6-20
6.4.1	Internal Loopback Mode	6-20
6.4.2	External Loopback Mode	6-21
6.4.3	Driver Entering Loopback Mode	6-21
6.4.4	Driver Restoring Normal Operation	6-22
6.5	Full-Duplex Operation	6-22
6.6	Autonegotiation	6-23
6.7	Capture Effect—A Value-Added Feature	6-25
6.7.1	What Is Capture Effect?	6-25
6.7.2	Resolving Capture Effect	6-26
6.7.3	Enhanced Resolution for Capture Effect	6-27
6.8	Jabber and Watchdog Timers	6-27

7 Power-Management and Power-Saving Support

7.1	Overview	7-1
7.2	OnNow and ACPI Power-Management Mechanism	7-2
7.2.1	Advanced Configuration and Power Interface (ACPI) Specification	7-2
7.2.1.1	PCI Power Management	7-2
7.2.2	OnNow Network Device Class Power Management Specification	7-3
7.2.3	The 21143 Support for OnNow and ACPI	7-4
7.2.3.1	Software Procedure for Power States Transitions	7-7
7.3	Remote Wake-Up LAN Mode Operation	7-8
7.3.1	Remote Wake-Up-LAN Mode with Main System Power Off	7-9
7.3.2	Remote Wake-Up-LAN Mode with Main System Power On	7-10
7.3.3	Invalid Password Limiter	7-11
7.4	Power-Saving Modes	7-12
7.4.1	Sleep Power-Saving Mode	7-12
7.4.2	Snooze Power-Saving Mode	7-13
7.5	Power-Management and Power-Saving Modes	7-14

8 External Ports

8.1	Overview	8-1
8.2	Boot ROM and Serial ROM Connection	8-1
8.2.1	Boot ROM Size	8-2
8.3	Boot ROM Operations	8-3
8.3.1	Byte Read	8-3
8.3.2	Byte Write	8-4
8.3.3	Dword Read	8-5

8.4	Serial ROM	8-6
8.4.1	Read Operation	8-8
8.4.2	Write Operation	8-11
8.5	External Register Operation	8-14
8.6	General-Purpose Port and LEDs	8-15

A Joint Test Action Group—Test Logic

A.1	General Description	A-1
A.2	Registers	A-2
A.2.1	Instruction Register	A-2
A.2.2	Bypass Register	A-3
A.2.3	Boundary-Scan Register	A-3
A.2.4	Test Access Port Controller	A-5

B DNA CSMA/CD Counters and Events Support

B.1	CSMA/CD Counters	B-1
-----	----------------------------	-----

C Hash C Routine

C.1	Little Endian Architecture Hash C Routine	C-1
C.2	Big Endian Architecture Hash C Routine	C-2

D Port Selection Procedure

D.1	MII Port Selection	D-1
D.2	SYM Port Selection	D-2
D.3	10BASE-T Port Selection	D-2
D.4	AUI Port Selection	D-3

E General-Purpose Port and LED Programming

E.1	Input Port Selection with Interrupt	E-2
E.2	Input Port Selection Without Interrupt	E-2
E.3	Output Port Selection	E-2
E.4	LED/Control Selection	E-2

F 21143 Magic Packet Format

G Filtering Setup Frame Buffer Examples

H Wake-Up Frame Filter Register Block Programming Examples

I Support, Products, and Documentation

Index

Examples

F-1	21143 Magic Packet Fields.....	F-3
G-1	Perfect Filtering Buffer	G-1
G-2	Imperfect Filtering Buffer.....	G-2
H-1	Wake-Up upon Unicast IP, Ethernet Frame Format	H-1
H-2	Filter Formats for Frames.....	H-2
H-3	Filter Formats for Frames.....	H-6

Figures

1-1	21143 Block Diagram	1-8
2-1	21143 Pinout Diagram (Top View)	2-2
3-1	21143 Memory Map	3-2
3-2	Configuration Register Structure.	3-5
3-3	CFID Register Bit Fields	3-6
3-4	CFCS Register Bit Fields	3-7
3-5	21143 CFRV Register Bit Fields.	3-10
3-6	CFLT Configuration Latency Timer Register.	3-11
3-7	CBIO Register Bit Fields	3-13
3-8	CBMA Register Bit Fields	3-14
3-9	CCIS Register Bit Fields	3-15
3-10	CSID Register Bit Fields	3-16
3-11	CBER Register Bit Fields	3-17
3-12	CCAP Register Bit Fields	3-18
3-13	CFIT Register Bit Fields	3-19
3-14	CCID Register Bit Fields	3-21
3-15	CPMC Register Bit Fields	3-23
3-16	CFDD Register Bit Fields	3-25
3-17	CWUA0 Register Bit Fields.	3-26
3-18	CWUA1 Register Bit Fields.	3-27
3-19	SOP0 Register Bit Fields	3-28
3-20	SOP1 Register Bit Fields	3-29
3-21	CWUC Register Bit Fields.	3-31
3-22	CSR0 Bus Mode Register.	3-35
3-23	CSR1 Register Bit Field	3-39
3-24	CSR1-PM Register Bit Field	3-40
3-25	Wake-Up Frame Filter Register Structure.	3-41
3-26	Filter i Byte Mask Bit Fields.	3-41
3-27	Filter i Command Bit Fields	3-42
3-28	Filter i Offset Bit Fields.	3-44
3-29	Filter i CRC-16 Bit Fields	3-44
3-30	CSR2 Register Bit Field	3-46
3-31	CSR2-PM Register Bit Field	3-47
3-32	CSR3 Register Bit Field	3-49
3-33	CSR4 Register Bit Field	3-50
3-34	CSR5 Register Bit Fields	3-52
3-35	CSR6 Register Bit Fields	3-59
3-36	CSR7 Register Bit Fields	3-67
3-37	CSR8 Missed Frames and Overflow Counter.	3-71
3-38	CSR9 Register Bit Fields	3-72
3-39	CSR10 Register Bit Field	3-75
3-40	CSR11 Register Bit Fields	3-76
3-41	CSR12 Register Bit Fields	3-78
3-42	CSR13 Register Bit Fields	3-81

3-43	CSR14 Register Bit Fields	3-82
3-44	CSR15 Register Bit Fields	3-87
3-45	FER Register Bit Fields	3-97
3-46	FEMR Register Bit Fields	3-98
3-47	FPSR Register Bit Fields	3-99
3-48	FFER Register Bit Fields	3-101
4-1	Descriptor Ring and Chain Structure Examples	4-3
4-2	Receive Descriptor Format	4-4
4-3	RDES0 Bit Fields	4-5
4-4	RDES1 Bit Fields	4-9
4-5	RDES2 Bit Field	4-10
4-6	RDES3 Bit Field	4-11
4-7	Transmit Descriptor Format	4-13
4-8	TDES0 Bit Fields	4-13
4-9	TDES1 Bit Fields	4-16
4-10	TDES2 Bit Field	4-19
4-11	TDES3 Bit Field	4-19
4-12	Perfect Filtering Setup Frame Buffer Format	4-22
4-13	Imperfect Filtering	4-23
4-14	Imperfect Filtering Setup Frame Buffer Format	4-24
5-1	Slave Read Cycle	5-4
5-2	Slave Write Cycle	5-5
5-3	Configuration Read Cycle	5-6
5-4	Bus Arbitration	5-7
5-5	Memory Read Cycle	5-9
5-6	Memory Write Cycle	5-10
5-7	21143-Initiated Disconnect Cycle	5-11
5-8	21143-Initiated Retry Cycle	5-12
5-9	Normal Completion	5-14
5-10	Master Abort	5-15
5-11	Target Abort	5-16
5-12	Target Disconnect	5-17
5-13	Target Retry	5-18
5-14	Parity Operation	5-19
5-15	PCI/CardBus Clock—Restart or Speed-Up	5-20
5-16	PCI/CardBus Clock—Maintaining Speed	5-21
6-1	Ethernet Frame Format	6-10
6-2	Preamble Recognition Sequence in 10BASE-T or AUI Mode	6-17
8-1	Boot ROM, Serial ROM, and External Register Connection	8-2
8-2	Boot ROM Byte Read Cycle	8-4
8-3	Boot ROM Byte Write Cycle	8-5
8-4	Boot ROM Dword Read Cycle	8-6
8-5	Read Cycle (Page 1 of 2)	8-9
8-6	Read Cycle (Page 2 of 2)	8-10
8-7	Read Operation	8-11
8-8	Write Cycle (Page 1 of 2)	8-12
8-9	Write Cycle (Page 2 of 2)	8-13

8-10	Write Operation.....	8-14
------	----------------------	------

Tables

2-1	Functional Description of 21143 Signals	2-4
3-1	Configuration Registers Mapping	3-4
3-2	CFID Register Bit Fields Description	3-6
3-3	CFID Register Access Rules	3-6
3-4	CFCS Register Bit Fields Description	3-8
3-5	CFCS Register Access Rules	3-9
3-6	CFRV Register Bit Fields Description	3-10
3-7	21143 Revision and Step Number	3-10
3-8	CFRV Register Access Rules	3-11
3-9	CFLT Register Bit Fields Description	3-12
3-10	CFLT Access Rules	3-12
3-11	CBIO Register Bit Fields Description	3-13
3-12	CBIO Register Access Rules	3-13
3-13	CBMA Register Bit Fields Description	3-14
3-14	CBMA Register Access Rules	3-14
3-15	CCIS Register Bit Fields Description	3-15
3-16	CCIS Register Access Rules	3-16
3-17	CSID Register Bit Fields Description	3-16
3-18	CSID Register Access Rules	3-17
3-19	CBER Register Bit Fields Description	3-17
3-20	CBER Register Access Rules	3-18
3-21	CCAP Register Bit Fields Description	3-18
3-22	CCAP Register Access Rules	3-19
3-23	CFIT Register Bit Fields Description	3-19
3-24	CFIT Register Access Rules	3-20
3-25	CCID Register Bit Fields Description	3-21
3-26	CCID Register Access Rules	3-23
3-27	CPMC Register Bit Fields Description	3-23
3-28	CPMC Register Access Rules	3-24
3-29	CFDD Register Bit Fields Description	3-25
3-30	CFDD Register Access Rules	3-25
3-31	CWUA0 Register Bit Fields Description	3-26
3-32	CWUA0 Register Access Rules	3-27
3-33	CWUA1 Register Bit Fields Description	3-27
3-34	CWUA1 Register Access Rules	3-28
3-35	SOP0 Register Bit Fields Description	3-29
3-36	SOP0 Register Access Rules	3-29
3-37	SOP1 Register Bit Fields Description	3-30
3-38	SOP1 Register Access Rules	3-30
3-39	CWUC Register Bit Fields Description	3-31
3-40	CWUC Register Access Rules	3-33
3-41	CSR Mapping	3-34
3-42	CSR0 Register Bit Fields Description	3-35
3-43	Transmit Automatic Polling Intervals	3-38

3-44	CSR0 Access Rules	3-38
3-45	Cache Alignment Bits	3-39
3-46	CSR1 Register Bit Field Description	3-39
3-47	CSR1 Register Access Rules	3-39
3-48	CSR1-PM Register Bit Field Description	3-40
3-49	CSR1-PM Register Access Rules	3-40
3-50	Filter i Byte Mask Descriptions	3-42
3-51	Filter i Byte Mask Register Access Rules	3-42
3-52	Filter i Command Descriptions	3-43
3-53	Filter i Command Register Access Rules	3-43
3-54	Filter i Offset Descriptions	3-44
3-55	Filter i Offset Register Access Rules	3-44
3-56	Filter i CRC-16 Descriptions	3-45
3-57	Filter i CRC-16 Register Access Rules	3-45
3-58	CSR2 Register Bit Field Description	3-46
3-59	CSR2 Register Access Rules	3-46
3-60	CSR2-PM Register Bit Field Description	3-47
3-61	CSR2-PM Register Access Rules	3-48
3-62	CSR3 Register Bit Fields Description	3-49
3-63	CSR3 Register Access Rules	3-50
3-64	CSR4 Register Bit Fields Description	3-50
3-65	CSR4 Register Access Rules	3-50
3-66	CSR5 Register Bit Fields Description	3-52
3-67	Fatal Bus Error Bits	3-57
3-68	Transmit Process State	3-57
3-69	Receive Process State	3-58
3-70	CSR5 Register Access Rules	3-58
3-71	CSR6 Register Bit Fields Description	3-59
3-72	Transmit Threshold	3-64
3-73	Port and Data Rate Selection	3-64
3-74	Loopback Operation Mode	3-65
3-75	Filtering Mode	3-65
3-76	CSR6 Register Access Rules	3-66
3-77	CSR7 Register Bit Fields Description	3-68
3-78	CSR7 Register Access Rules	3-70
3-79	CSR8 Register Bit Fields Description	3-71
3-80	CSR8 Register Access Rules	3-71
3-81	CSR9 Register Bit Fields Description	3-73
3-82	CSR9 Register Access Rules	3-75
3-83	CSR10 Register Bit Field Description	3-75
3-84	CSR10 Register Access Rules	3-76
3-85	CSR11 Register Bit Fields Description	3-77
3-86	CSR11 Register Access Rules	3-78
3-87	CSR12 Register Bit Fields Description	3-78
3-88	CSR12 Register Access Rules	3-81
3-89	CSR13 Register Bit Fields Description	3-81
3-90	CSR13 Register Access Rules	3-82

3-91	CSR14 Register Bit Fields Description	3-83
3-92	CSR14 Register Access Rules	3-85
3-93	Twisted-Pair Compensation Behavior	3-86
3-94	CSR15 Register Bit Fields Description	3-88
3-95	CSR15 Register Access Rules	3-91
3-96	Programming MII/SYM Operating Modes	3-92
3-97	Programming 10BASE-T, AUI, and BNC Operating Modes with Autosensing Disabled and Autonegotiation Disabled	3-92
3-98	Programming 10BASE-T, AUI, and BNC Operating Modes with Autosensing Disabled and Autonegotiation Enabled	3-93
3-99	Programming 10BASE-T, AUI, and BNC Operating Modes with Autosensing Enabled and Autonegotiation Disabled	3-94
3-100	Programming 10BASE-T, AUI, and BNC Operating Modes with Autosensing Enabled and Autonegotiation Enabled	3-94
3-101	CardBus Status Changed Register Mapping	3-96
3-102	FER Register Bit Fields Description	3-97
3-103	FER Register Access Rules	3-97
3-104	FEMR Register Bit Fields Description	3-98
3-105	FEMR Register Access Rules	3-99
3-106	FPSR Register Bit Fields Description	3-100
3-107	FPSR Register Access Rules	3-100
3-108	FFER Register Bit Fields Description	3-101
3-109	FFER Register Access Rules	3-101
4-1	RDES0 Bit Fields Description	4-6
4-2	RDES1 Bit Fields Description	4-10
4-3	RDES2 Bit Field Description	4-11
4-4	RDES3 Bit Field Description	4-11
4-5	Receive Descriptor Status Validity	4-12
4-6	TDES0 Bit Fields Description	4-14
4-7	TDES1 Bit Fields Description	4-16
4-8	Filtering Type	4-18
4-9	TDES2 Bit Field Description	4-19
4-10	TDES3 Bit Field Description	4-19
4-11	Transmit Descriptor Status Validity	4-20
4-12	Arbitration Scheme	4-27
4-13	Receive Process State Transitions	4-33
4-14	Transmit Process State Transitions	4-36
5-1	Bus Commands	5-2
6-1	IEEE 802.3 and MII/SYM Signals	6-2
6-2	Crystal Oscillator Specification	6-7
6-3	Ethernet Frame Format	6-10
6-4	Frame Format Table	6-11
6-5	Ethernet Receive Address Groups	6-12
6-6	Transmit Parameter Values	6-16
6-7	Destination Address Bit 1	6-18
6-8	Autonegotiation Modes Selection	6-24
6-9	Capture-Effect Sequence	6-26

6-10	2-0 Backoff Algorithm	6-27
7-1	Power State Definitions	7-2
7-2	Power-Management Event Capabilities	7-6
7-3	Driver Procedure Upon Moving Between Power States	7-7
8-1	Mode Selection and LED Indicator Pin Descriptions	8-15
A-1	Instruction Register	A-2
B-1	CSMA/CD Counters	B-1
F-1	Magic Packet Format for the 21143	F-2

Purpose and Audience

The DIGITAL Semiconductor 21143 PCI/CardBus 10/100-Mb/s Ethernet LAN Controller Hardware Reference Manual describes the operation of the DIGITAL Semiconductor 21143 10/100-Mb/s Ethernet LAN Controller (also referred to as the 21143). This manual is for designers who use the 21143.

Manual Organization

This manual contains eight chapters, nine appendixes, and an index.

- Chapter 1, Introduction, includes a general description of the 21143. It also provides an overview of the 21143 hardware components.
- Chapter 2, Signal Descriptions, provides the physical layout of the 21143 and describes each of the input and output signals.
- Chapter 3, Registers, provides a complete bit description of the 21143 command and status registers (CSRs) and the configuration registers.
- Chapter 4, Host Communication, describes how the 21143 communicates with the host by using descriptor lists and data buffers. It also describes the transmit and receive processes.
- Chapter 5, Host Bus Operation, provides a description of the read, write, and termination cycles.
- Chapter 6, Network Interface Operation, describes the MII, 10BASE-T, and AUI ports. It includes a complete description of media access control (MAC) operations. It also provides detailed transmitting and receiving operation information.
- Chapter 7, Power-Management and Power-Saving Support, describes power-management features, associated specifications, and how to remotely power up a sleeping workstation.

- Chapter 8, External Ports, describes the interface and operation of the MicroWire serial ROM, the boot ROM, the general-purpose port, and the network activity LEDs.
- Appendix A, Joint Test Action Group—Test Logic, provides descriptions of testing, observing, and modifying circuit activity during normal operation.
- Appendix B, DNA CSMA/CD Counters and Events Support, describes features that support the driver in implementing and reporting the specified counters and events.
- Appendix C, Hash C Routine, provides an example of a C routine that generates a hash index for a given Ethernet address.
- Appendix D, Port Selection Procedure, provides information about selecting the MII, 10BASE-T, AUI, and BNC ports.
- Appendix E, General-Purpose Port and LED Programming, contains information about general-purpose port and LED programming.
- Appendix F, 21143 Magic Packet Format, describes the Magic Packet format used by the 21143.
- Appendix G, Filtering Setup Frame Buffer Examples, provides examples of perfect and imperfect filtering setup frame buffers.
- Appendix H, Wake-Up Frame Filter Register Block Programming Examples, provides examples of wake-up frame patterns and how the wake-up frame filter register block should be programmed.
- Appendix I, Support, Products, and Documentation, contains information about technical support and ordering information.

Document Conventions

Some tables use the values 1, 0, and X. An X signifies a don't care (1 or 0) convention, which can be determined by the system designer.

In Chapters 3 and 4, all shaded bits in the figures are reserved and should be written by the driver as 0.

Introduction

This chapter provides a general description of the DIGITAL Semiconductor 21143 10/100-Mb/s PCI/CardBus Ethernet LAN Controller (21143), its features, and an overview of the hardware.

1.1 General Description

The 21143 is an Ethernet LAN controller for both 100-Mb/s and 10-Mb/s data rates, which provides a direct interface to the peripheral component interconnect (PCI) local bus or the CardBus. The 21143 interfaces to the host processor by using onchip command and status registers (CSRs) and a shared host memory area, set up mainly during initialization. This minimizes processor involvement in the 21143 operation during normal reception and transmission.

The 21143 is optimized for low power PCI/CardBus based systems and supports two types of power-management mechanisms. The main mechanism is based upon the OnNow architecture, which is required for PC 97 and PC 98.¹ The alternative mechanism is based upon the older remote wake-up-LAN mechanism.

Large FIFOs allow the 21143 to efficiently operate in systems with longer latency periods. Bus traffic is also minimized by filtering out received runt frames and by automatically retransmitting collided frames without a repeated fetch from the host memory. The 21143 provides an upgradable boot ROM interface.

¹This feature is only supported in the 21143-PD and the 21143-TD.

General Description

The 21143 provides three network ports: a 10BASE-T 10-Mb/s port, an attachment unit interface (AUI) 10-Mb/s port, and a media-independent/symbol interface (MII/SYM) 10/100-Mb/s port. The 10BASE-T port provides a direct Ethernet connection to the twisted-pair (TP) interface. The AUI port provides a direct Ethernet connection to the AUI.

The MII/SYM port supports two operational modes:

- MII mode—A full implementation of the MII standard
- SYM mode—Symbol interface to an external 100-Mb/s front-end decoder (ENDEC). In this mode the 21143 uses an onchip physical coding sublayer (PCS) and a scrambler/descrambler circuit to enable a low-cost 100BASE-T implementation.

The 21143 is capable of functioning in a full-duplex environment for the MII/SYM and 10BASE-T ports.

1.2 Features

The 21143 has the following features:

Power Management and Power Savings:

- Fully compliant with Revision 1.0 of the *Network Device Class Power Management Specification*, under the OnNow Architecture for Microsoft's *PC 97 Hardware Design Guide* and *PC 98 System Design Guide*.¹
- Supports all wake-up events defined in Revision 1.0 of the *Network Device Class Power Management Specification*, including:¹
 - Pattern matching
 - Link change
 - Magic Packet
- Fully compliant with Revision 1.0 of the *Advanced Configuration and Power Interface (ACPI) Specification*.¹
- Fully compliant with Revision 1.0 of the *PCI Bus Power Management Interface Specification*.¹
- Implements low-power management with two power-saving modes (sleep and snooze), with the device powering up in sleep mode. Powering up in sleep mode allows CardBus PC cards to meet the requirement of consuming less than 70 mA of supply current after power-up.
- Supports remote wake-up-LAN, which is a feature based upon Advanced Micro Device's Magic Packet technology that allows sleeping workstations to be remotely powered up.
- Supports SecureON, which is a security feature that can be added to the Advanced Micro Device's Magic Packet technology.
- Implements low-power, 3.3-V CMOS technology.

¹This feature is only supported in the 21143-PD and the 21143-TD.

Features

PCI and CardBus Features:

- Supports PCI and CardBus interfaces.
- Supports PCI/CardBus clock control through clkrun.
- Supports CardBus **estschg** pin and Status Changed registers.
- Supports automatic loading of subvendor ID and CardBus card information structure (CIS) pointer from serial ROM to configuration registers.
- Supports storage of CardBus card information structure (CIS) in the serial ROM or the expansion ROM.¹
- Supports the advanced PCI/CardBus read multiple, read line, and write and invalidate commands.
- Supports an unlimited PCI/CardBus burst.
- Supports PCI/CardBus clock speed frequency from dc to 33 MHz; network operation with PCI clock from 20 MHz to 33 MHz.

Host Interface Features:

- Includes a powerful onchip direct memory access (DMA) with programmable burst size, providing low CPU utilization.
- Supports early interrupt on transmit and receive.
- Supports interrupt mitigation on transmit and receive.²
- Supports big or little endian byte ordering for buffers and descriptors.
- Implements unique, patent-pending intelligent arbitration between DMA channels to minimize underflow and overflow.
- Contains large independent receive and transmit FIFOs.

¹For the 21143–PB, 21143–TB, 21143–PC, and the 21143–TC, the CIS can only be stored in the expansion ROM.

²This feature is only supported in the 21143–PD and the 21143–TD.

Network Side Features:

- Supports three network ports: 10BASE-T (10 Mb/s), AUI (10 Mb/s), and MII/SYM (10/100 Mb/s).
- Contains a variety of flexible address filtering modes.
- Contains onchip PCS and scrambler/descrambler for 100BASE-TX.
- Implements signal-detect filtering to avoid false detection of link with 100BASE-TX symbol interfaces.¹
- Enables automatic detection and correction of 10BASE-T receive polarity.
- Contains onchip integrated AUI port and a 10BASE-T transceiver.
- Supports autodetection between 10BASE-T, AUI, and MII/SYM ports.
- Supports IEEE 802.3 Auto-Negotiation algorithm of full-duplex and half-duplex operation for 10 Mb/s and 100 Mb/s (NWAY).
- Offers a unique, patented solution to Ethernet capture-effect problem.
- Supports full-duplex operation on both MII/SYM and 10BASE-T ports.
- Provides internal and external loopback capability on all network ports.
- Supports IEEE 802.3 and ANSI 8802-3 Ethernet standards.

Other Features:

- Provides MicroWire interface for serial ROM (1K and 4K EEPROM).
- Provides an upgradable boot ROM interface up to 256KB.
- Provides LED indications for various network activity.
- Supports interrupts from two general-purpose pins.
- Implements test-access port (JTAG-compatible) with boundary-scan pins.
- Contains a 4-bit, general-purpose programmable register and corresponding I/O pins with the ability to generate interrupts from two general-purpose pins.

¹This feature is only supported in the 21143-PD and the 21143-TD.

Microarchitecture

1.3 Microarchitecture

The following list describes the 21143 hardware components, and Figure 1–1 shows a block diagram of the 21143:

- PCI/CardBus interface—Includes all interface functions to the PCI and CardBus bus; handles all interconnect control signals; and executes DMA and I/O transactions
- Boot ROM port—Provides an interface to perform read and write operations to the boot ROM; supports accesses to bytes or longwords (32-bit); and provides the ability to connect an external 8-bit register to the boot ROM port
- Serial ROM port—Provides a direct interface to a MicroWire ROM for storage of the Ethernet address and system parameters
- General-purpose register—Enables software use for input or output functions and LEDs
- DMA—Contains independent receive and transmit controllers; handles data transfers between CPU memory and onchip memory
- FIFOs—Contains independent FIFOs for receive and transmit; supports automatic packet deletion on receive (runt packets or after a collision) and packet retransmission after a collision on transmit
- RxM—Handles all CSMA/CD¹ receive operations, and transfers the network data from the ENDEC to the receive FIFO
- TxM—Handles all CSMA/CD MAC² transmit operations, and transfers data from transmit FIFO to the ENDEC for transmission
- SIA interface—Performs 10-Mb/s physical layer network operations; implements the AUI and 10BASE-T functions, including the Manchester encoder and decoder functions
- NWAY—Implements the IEEE 802.3 Auto-Negotiation algorithm
- Physical coding sublayer—Implements the encoding and decoding sublayer of the 100BASE-TX (CAT5) specification, including the squelch feature

¹Carrier-sense multiple access with collision detection.

²Media access control.

- Scrambler/descrambler—Implements the twisted-pair physical layer medium dependent (TP-PMD) scrambler/descrambler scheme for 100BASE-TX
- Three network interfaces—An AUI interface, a 10BASE-T interface, and an MII/SYM interface provide a full MII signal interface and direct interface to the 100-Mb/s ENDEC for CAT5
- Wake-up-controller—Enables power-management control compliant with the ACPI¹ and remote power-up capabilities using the remote wake-up-LAN mechanism

¹This feature is only supported in the 21143-PD and the 21143-TD.

Microarchitecture

Figure 1-1 21143 Block Diagram

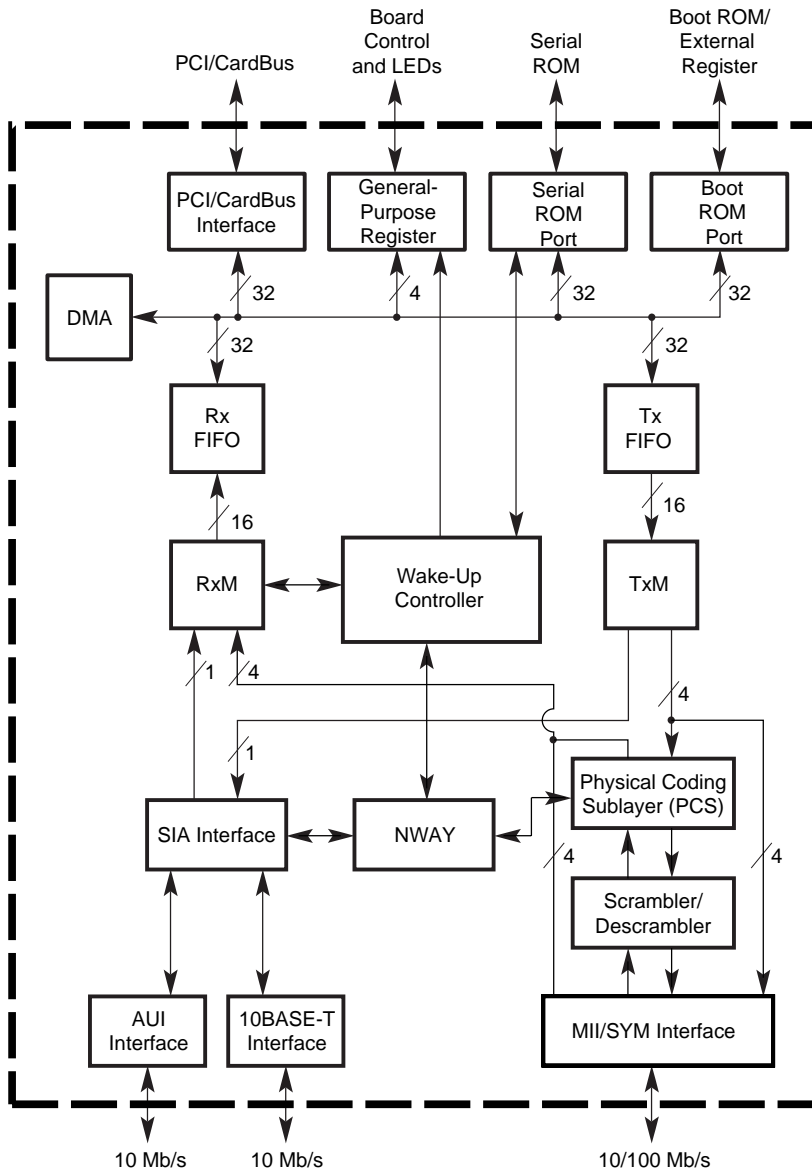

FM-06117.A14

Signal Descriptions

This chapter describes the 21143 signals.

2.1 21143 Pinout

The 21143 is offered in two package styles: a 144-pin MQFP and a 144-pin LQFP. Figure 2–1 shows the 21143 pinout used by both package types.

21143 Pinout

Figure 2–1 21143 Pinout Diagram (Top View)

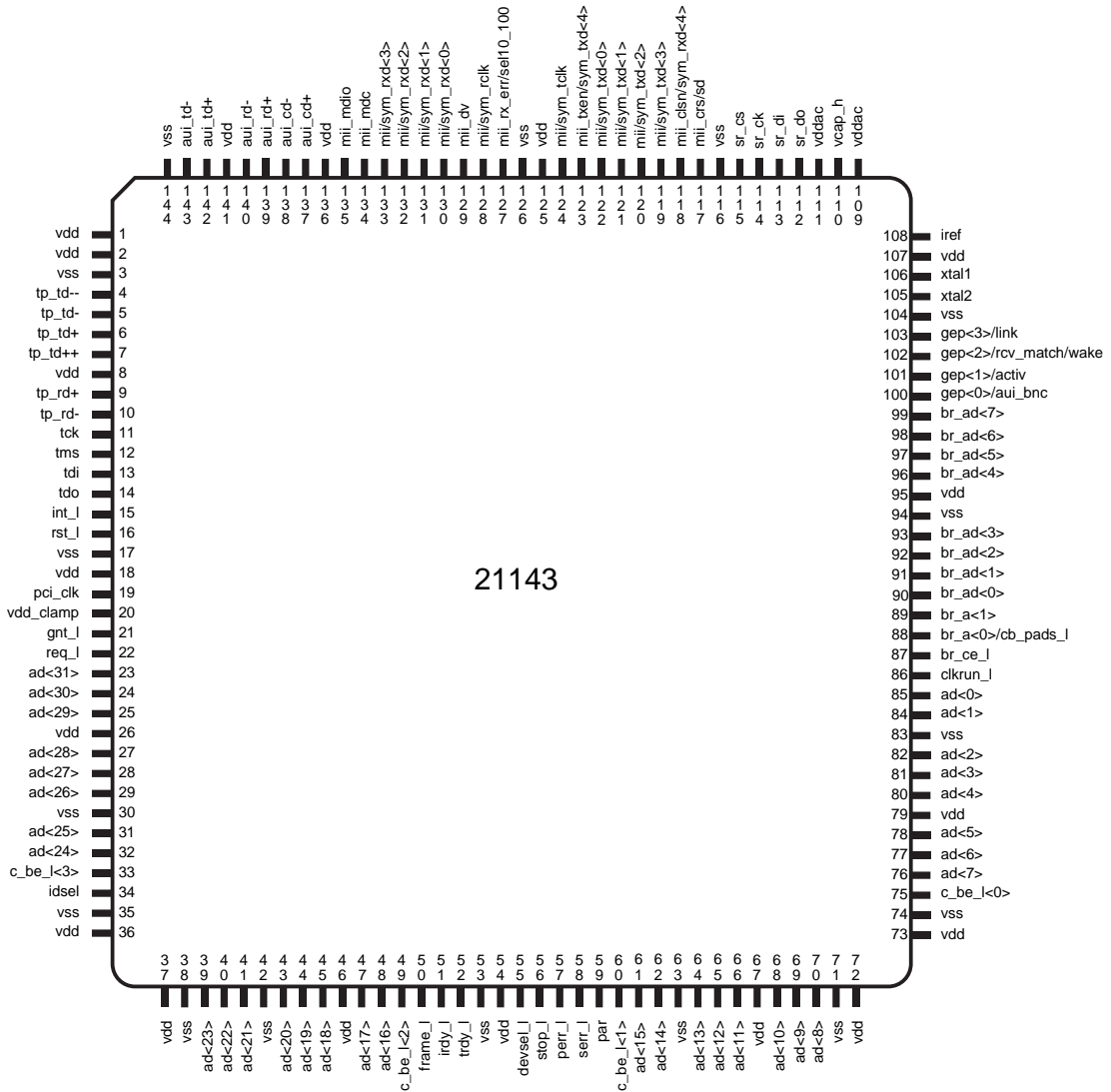

LJ-04940.A14

2.2 Signal Descriptions

The following terms describe the 21143 pinout used in Table 2–1:

- Address phase
Address and appropriate bus commands are driven during this cycle.
- Data phase
Data and the appropriate byte enable codes are driven during this cycle.
- **_l**
All pin names with the **_l** suffix are asserted low.

The following abbreviations are used in Table 2–1:

O = Output

I/O = Input/output

O/D = Open drain

P = Power

The following signals have an internal pull-up:

tms

tdi

br_ce_l

sr_do

mii/sym_tclk

Signal **sr_cs** has an internal pull-down.

Signal Descriptions

Table 2–1 provides a functional description of each of the 21143 signals. These signals are listed alphabetically.

Table 2–1 Functional Description of 21143 Signals

(Sheet 1 of 11)

Signal	Type	Pin Number	Description
ad<31:0>	I/O	23, 24, 25, 27, 28, 29, 31, 32, 39, 40, 41, 43, 44, 45, 47, 48, 61, 62, 64, 65, 66, 68, 69, 70, 76, 77, 78, 80, 81, 82, 84, 85	32-bit PCI address and data lines. Address and data bits are multiplexed on the same pins. During the first clock cycle of a transaction, the address bits contain a physical address (32 bits). During subsequent clock cycles, these same lines contain 32 bits of data. A 21143 bus transaction consists of an address phase followed by one or more data phases. The 21143 supports both read and write bursts (in master operation only). Little and big endian byte ordering can be used.
au_i_cd-	I	138	Attachment unit interface receive collision differential negative data.
au_i_cd+	I	137	Attachment unit interface receive collision differential positive data.
au_i_rd-	I	140	Attachment unit interface receive differential negative data.
au_i_rd+	I	139	Attachment unit interface receive differential positive data.
au_i_td-	O	143	Attachment unit interface transmit differential negative data.
au_i_td+	O	142	Attachment unit interface transmit differential positive data.

Table 2–1 Functional Description of 21143 Signals

(Sheet 2 of 11)

Signal	Type	Pin Number	Description
br_a<0>/cb_pads_l	O	88	<p>Boot ROM address line bit 0. In a 256KB configuration, this pin also carries in two consecutive address cycles, boot ROM address bits 16 and 17.</p> <p>This pin also determines the type of signals to use for the PCI/CardBus output pins, either PCI or CardBus.¹ By default, this pin selects PCI signaling. To select CardBus signaling, this pin must be connected to a pull-down resistor.</p> <p>Note: The 21143–PB, 21143–TB, 21143–PC, and the 21143–TC only support signaling for PCI. To meet the signaling requirements for CardBus, external series resistors must be added to these devices.</p>
br_a<1>	O	89	<p>Boot ROM address line bit 1. This pin also latches the boot ROM address and control lines by the two external latches.</p>
br_ad<7:0>	I/O	90, 91, 92, 93, 96, 97, 98, 99	<p>Boot ROM address and data multiplexed lines bits 7 through 0. In two consecutive address cycles, these lines contain the boot ROM address pins 7 through 2, oe_l and we_l in the first cycle; and these lines contain boot ROM address pins 15 through 8 in the second cycle. During the data cycle, bits 7 through 0 contain data.</p>
br_ce_l	O	87	<p>Boot ROM or external register chip enable.</p>
c_be_l<3:0>	I/O	33, 49, 60, 75	<p>Bits 0 through 3 of the bus command and byte enable lines. Bus command and byte enable are multiplexed on the same PCI pins.</p> <p>During the address phase of the transaction, these 4 bits provide the bus command.</p> <p>During the data phase, these 4 bits provide the byte enable. The byte enable determines which byte lines carry valid data. For example, bit 0 applies to byte 0, and bit 3 applies to byte 3.</p>

Signal Descriptions

Table 2–1 Functional Description of 21143 Signals

(Sheet 3 of 11)

Signal	Type	Pin Number	Description
clkrun_1	I/O O/D	86	<p>PCI/CardBus clock run indication. The host system asserts this signal to indicate normal operation of the clock. The host system deasserts clkrun_1 when the clock is going to be stopped or slowed down to a nonoperational frequency.</p> <p>If the clock is needed by the 21143, the 21143 asserts clkrun_1, requesting normal clock operation to be maintained or restored. Otherwise, the 21143 allows the system to stop the clock.</p> <p>Note: The 21143–PB, 21143–TB, 21143–PC, and the 21143–TC continuously request the host for the clock, which prevents the clock from stopping or slowing down.</p>
devsel_1	I/O	55	<p>Device select is asserted by the target of the current bus access. When the 21143 is the initiator of the current bus access, it expects the target to assert devsel_1 within 5 bus cycles, confirming the access. If the target does not assert devsel_1 within the required bus cycles, the 21143 aborts the cycle. To meet the timing requirements, the 21143 asserts this signal in a medium speed (within 2 bus cycles).</p>
frame_1	I/O	50	<p>The frame_1 signal is driven by the bus master to indicate the beginning and duration of an access. The frame_1 signal asserts to indicate the beginning of a bus transaction. While frame_1 is asserted, data transfers continue. The frame_1 signal deasserts to indicate that the next data phase is the final data phase transaction.</p>

Table 2–1 Functional Description of 21143 Signals

(Sheet 4 of 11)

Signal	Type	Pin Number	Description
gep<0>/au_i_bnc	I/O	100	<p>This pin can be configured by software to be:</p> <ul style="list-style-type: none"> • A general-purpose pin that performs either input or output functions. This general-purpose pin can provide an interrupt when functioning as an input. • A control pin that provides an AUI (10BASE5) or BNC (10BASE2) select line. <p>This control pin is mainly used to enable the external BNC transceiver in 10BASE2 mode. When set, the 10BASE5 mode is selected. When reset, the 10BASE2 mode is selected.</p> <p>Note: This control pin is internally forced to the au_i_bnc function when the 21143 is in remote wake-up-LAN mode.</p>
gep<1>/activ	I/O	101	<p>This pin can be configured by software to be:</p> <ul style="list-style-type: none"> • A general-purpose pin that performs either input or output functions. This general-purpose pin can provide an interrupt when functioning as an input. • A status pin that provides an LED that indicates either receive or transmit activity.
gep<2>/rcv_match/wake	I/O	102	<p>This pin can be configured by software to be:</p> <ul style="list-style-type: none"> • A general-purpose pin that performs either input or output functions. • A status pin that provides an LED that indicates a receive packet has passed address recognition. <p>This pin can also be controlled by PME_Enable bit (Func0_HwOptions<3>) in the serial ROM to be a wake-up event pin¹ that can be connected to pin pme# of the PCI connector or pin cstschg of the CardBus connector. When this pin is in a wake function, bit MiscHwOptions<1> in the serial ROM determines the polarity. The PME function takes precedence over the Magic Packet indication function.</p> <p>When the 21143 is in remote wake-up-LAN mode, this pin is used as an indicator that a Magic Packet has been successfully detected.</p>

Signal Descriptions

Table 2–1 Functional Description of 21143 Signals

(Sheet 5 of 11)

Signal	Type	Pin Number	Description
gep<3>/link	I/O	103	<p>This pin can be configured by software to be:</p> <ul style="list-style-type: none"> • A general-purpose pin that performs either input or output functions.² • A status pin that provides an LED to indicate: <ul style="list-style-type: none"> –Network link integrity state for 10BASE-T or 100BASE-TX.³ –Both network activity and network link integrity state.¹ <p>For more information about LED indicators, see Section 8.6.</p> <ul style="list-style-type: none"> • An input link status pin for OnNow support. When used with an MII PHY device, this pin should be connected to the MII PHY link indication pin (the 21143 interprets link-pass when this pin is high).¹ <p>This pin should not be left unconnected.</p>
gnt_l	I	21	<p>Bus grant asserts to indicate to the 21143 that access to the bus is granted.</p>
idsel	I	34	<p>Initialization device select asserts to indicate that the host is issuing a configuration cycle to the 21143.</p>
int_l	O/D	15	<p>Interrupt request asserts when one of the appropriate bits of CSR5 sets and causes an interrupt, provided that the corresponding mask bit in CSR7 is not asserted. Interrupt request deasserts by writing a 1 into the appropriate CSR5 bit.</p> <p>If more than one interrupt bit is asserted in CSR5 and the host does not clear all input bits, the 21143 deasserts int_l for one cycle to support edge-triggered systems.</p>
iref	I	108	<p>Current reference input for the analog phase-locked loop logic.</p>
irdy_l	I/O	51	<p>Initiator ready indicates the bus master's ability to complete the current data phase of the transaction. A data phase is completed on any rising edge of the clock when both irdy_l and target ready trdy_l are asserted. Wait cycles are inserted until both irdy_l and trdy_l are asserted together.</p> <p>When the 21143 is the bus master, it asserts irdy_l during write operations to indicate that valid data is present on the 32-bit ad lines. During read operations, the 21143 asserts irdy_l to indicate that it is ready to accept data.</p>

Table 2–1 Functional Description of 21143 Signals

(Sheet 6 of 11)

Signal	Type	Pin Number	Description
mii_clsn/sym_rxd<4>	I	118	In MII mode (CSR6<18>=1, CSR6<23>=0), this pin functions as the collision detect. When the external physical layer protocol (PHY) device detects a collision, it asserts this pin. In SYM mode (CSR6<18>=1, CSR6<23>=1), this pin functions as receive data. This line along with the four receive lines (sym_rxd<4:0>) provides five parallel data lines in symbol form. This data is controlled by an external physical layer medium-dependent (PMD) device and should be synchronized to the sym_rclk signal.
mii_crs/sd	I	117	In MII mode this pin functions as the carrier sense and is asserted by the PHY when the media is active. In SYM mode this pin functions as the signal detect indication. It is controlled by an external PMD device.
mii_dv	I	129	Data valid is asserted by an external PHY when receive data is present on the mii_rxd lines and is deasserted at the end of the packet. This signal should be synchronized with the mii_rclk signal.
mii_mdc	O	134	MII management data clock is sourced by the 21143 to the PHY devices as a timing reference for the transfer of information on the mii_mdio signal.
mii_mdio	I/O	135	MII management data input/output transfers control information and status between the PHY and the 21143.
mii/sym_rclk	I	128	Supports either the 25-MHz or 2.5-MHz receive clock. This clock is recovered by the PHY.

Signal Descriptions

Table 2–1 Functional Description of 21143 Signals

(Sheet 7 of 11)

Signal	Type	Pin Number	Description
mii_rx_err/sel10_100	I/O	127	When used with an MII PHY device (CSR6<18>=1, CSR6<23>=0), this pin functions as receive error input. It is asserted when a data decoding error is detected by an external PHY device. This signal is synchronized to mii_rclk and can be asserted for a minimum of one receive clock. When asserted during a packet reception, it sets the cyclic redundancy check (CRC) error bit in the receive descriptor (RDES0). When used with a SYM PHY device (CSR6<23>=1), this pin functions as select 10/100 output. The signal sel10_100 equals 1 when the 21143 is in 100-Mb/s SYM mode (CSR6<18>=1) and equals 0 when the 21143 is in 10BASE-T/AUI mode (CSR6<18>=0).
mii/sym_rxd<3:0>	I	130, 131, 132, 133,	Four parallel receive data lines. This data is driven by an external PHY that attached the media and should be synchronized with the mii_rclk signal.
mii/sym_tclk	I	124	Supports the 25-MHz or 2.5-MHz transmit clock supplied by the external PMD device. This clock should always be active.
mii/sym_txd<3:0>	O	119, 120, 121, 122	Four parallel transmit data lines. This data is synchronized to the assertion of the mii_tclk signal and is latched by the external PHY on the rising edge of the mii_tclk signal.
mii_txen/sym_txd<4>	O	123	In MII mode, this pin functions as transmit enable. It indicates that a transmission is active on the MII port to an external PHY device. In SYM mode, this pin functions as transmit data. This line along with the four data transmit lines (sym_txd<3:0>) provides five parallel data lines in symbol form. The data is synchronized to the rising edge of the sym_tclk signal.
par	I/O	59	Parity is calculated by the 21143 as an even parity bit for the 32-bit ad and 4-bit c_be_1 lines. During address and data phases, parity is calculated on all the ad and c_be_1 lines whether or not any of these lines carry meaningful information.

Table 2–1 Functional Description of 21143 Signals

(Sheet 8 of 11)

Signal	Type	Pin Number	Description
pci_clk	I	19	The clock provides the timing for the 21143 related PCI bus transactions. All the bus signals are sampled on the rising edge of pci_clk . The clock frequency range is between 20 MHz and 33 MHz.
perr_l	I/O	57	Parity error asserts when a data parity error is detected. When the 21143 is the bus master and a parity error is detected, the 21143 asserts both CSR5 bit 13 (fatal bus error) and CFCS bit 24 (data parity report). Next, it completes the current data burst transaction, then stops operation. After the host clears the system error, the 21143 continues its operation. The 21143 asserts perr_l when a data parity error is detected in either a master-read or a slave-write operation.
req_l	O	22	Bus request is asserted by the 21143 to indicate to the bus arbiter that it wants to use the bus.
rst_l	I	16	Resets the 21143 to its initial state. This signal must be asserted for at least 10 active PCI clock cycles. When in the reset state, all PCI output pins are put into tristate and all PCI O/D signals are floated.
serr_l	O/D	58	If an address parity error is detected and CFCS bit 8 (serr_l enable) is enabled, 21143 asserts both serr_l (system error) and CFCS bit 30 (signal system error). When an address parity error is detected, system error asserts two clocks after the failing address.
sr_ck	O	114	Serial ROM clock signal. This pin provides a serial clock output for the serial ROM.
sr_cs	O	115	Serial ROM chip-select signal. This pin provides a chip select for the serial ROM.
sr_di	O	113	Serial ROM data-in signal. This pin serially shifts the write data from the 21143 to the serial ROM device.
sr_do	I	112	Serial ROM data-out signal. This pin serially shifts the read data from the serial ROM device to the 21143.

Signal Descriptions

Table 2–1 Functional Description of 21143 Signals

(Sheet 9 of 11)

Signal	Type	Pin Number	Description
stop_I	I/O	56	Stop indicator indicates that the current target is requesting the bus master to stop the current transaction. The 21143 responds to the assertion of stop_I when it is the bus master, either to disconnect, retry, or abort.
tck	I	11	JTAG clock shifts state information and test data into and out of the 21143 during JTAG test operations. If the JTAG port is unused, this pin should be connected to vss .
tdi	I	13	JTAG data in is used to serially shift test data and instructions into the 21143 during JTAG test operations.
tdo	O	14	JTAG data out is used to serially shift test data and instructions out of the 21143 during JTAG test operations.
tms	I	12	JTAG test mode select controls the state operation of JTAG testing in the 21143.
tp_rd-	I	10	Twisted-pair negative differential receive data from the twisted-pair lines.
tp_rd+	I	9	Twisted-pair positive differential receive data from the twisted-pair lines.
tp_td-	O	5	Twisted-pair negative differential transmit data. The positive and negative differential transmit data outputs are combined resistively outside the 21143 with equalization to compensate for intersymbol interference on the twisted-pair medium.
tp_td- -	O	4	
tp_td+	O	6	Twisted-pair positive differential transmit data. The positive and negative differential transmit data outputs are combined resistively outside the 21143 with equalization to compensate for intersymbol interference on the twisted-pair medium.
tp_td+ +	O	7	

Table 2–1 Functional Description of 21143 Signals

(Sheet 10 of 11)

Signal	Type	Pin Number	Description
trdy_1	I/O	52	Target ready indicates the target agent's ability to complete the current data phase of the transaction. A data phase is completed on any clock when both trdy_1 and irdy_1 are asserted. Wait cycles are inserted until both irdy_1 and trdy_1 are asserted together. When the 21143 is the bus master, target ready is asserted by the bus slave on the read operation, which indicates that valid data is present on the ad lines. During a write cycle, it indicates that the target is prepared to accept data.
vcap_h	I	110	Capacitor input for analog phase-locked loop logic.
vdd	P	1, 2, 8, 18, 26, 36, 37, 46, 54, 67, 72, 73, 79, 95, 107, 125, 136, 141	3.3-V supply input. These pins should be connected to the auxiliary power, if such power exists. Otherwise, these pins should be connected to the main power.
vddac	P	109, 111	Supplies +3.3-V input for analog phase-locked loop logic.
vdd_clamp	P	20	Supplies +5-V or +3.3-V reference for clamp logic. This pin is also used to identify the lack of main power when the auxiliary power is on. This pin should be connected to the main power.
vss	P	3, 17, 30, 35, 38, 42, 53, 63, 71, 74, 83, 94, 104, 116, 126, 144	Ground pins.

Signal Descriptions

Table 2–1 Functional Description of 21143 Signals

(Sheet 11 of 11)

Signal	Type	Pin Number	Description
xtal1	I	106	20-MHz crystal input, or crystal oscillator input.
xtal2	O	105	Crystal feedback output pin used for crystal connections only. If this pin is unused, then it should be unconnected.

¹This feature is only supported in the 21143–PD and the 21143–TD.

²In the 21143–PD and the 21143–TD, when used as a general-purpose input pin, this pin affects the link changed wake-up event.

³The 100BASE-TX link indication feature is only supported in the 21143–PD and the 21143–TD.

Registers

This chapter describes the 19 configuration registers,¹ the 18 command and status registers (CSRs),² and the 4 CardBus Status Changed registers³ of the 21143. The configuration registers are located in the configuration space and are accessed through configuration accesses. Of the configuration registers, 13 are standard registers that are defined in the *PCI Local Bus Specification*, while the other 6 are 21143-specific registers. The configuration registers are used for initialization and configuration, and accessed by system software.

The CSRs are 21143 specific. These registers can be mapped to either the host I/O address space or the host memory address space. The CSRs are accessed by the 21143 driver and are used for initialization, pointers, commands, and status reporting.

The CardBus Status Changed registers are standard registers that are defined in the PC Card Standard. These registers are located *only* in the host memory address space and are used for control and status in CardBus applications.

The 21143 implements two base address registers that can map the 21143 structures to the I/O and the memory address spaces. The I/O base address register (CBIO) maps only the 18 CSRs. The memory base address registers (CBMA) maps the 18 CSRs, the 4 CardBus Status Changed registers, and the serial ROM.

¹The 21143–PB, 21143–TB, 21143–PC, and the 21143–TC have 16 configuration registers.

²The 21143–PB, 21143–TB, 21143–PC, and the 21143–TC have 16 command and status registers.

³These registers exist only in the 21143–PD and the 21143–TD.

Figure 3–1 shows the 21143 structures that are mapped into the host memory address space.

Figure 3–1 21143 Memory Map

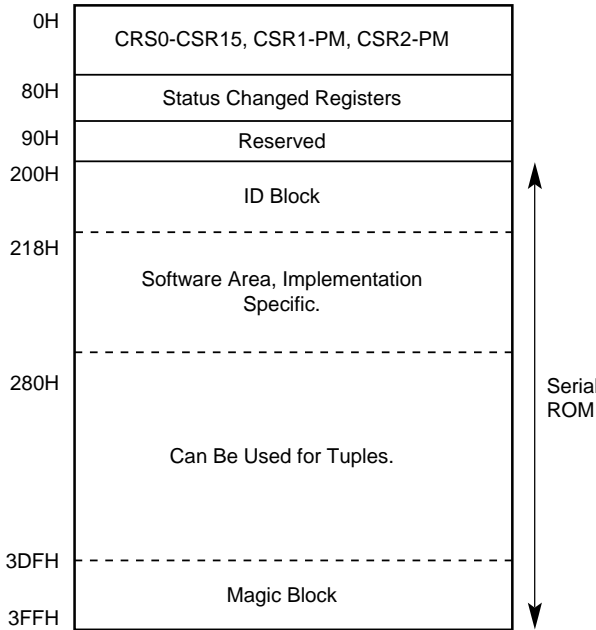

FM-06197.A14

Note: This figure shows the case where the serial ROM size is 4Kb when DIGITAL Semiconductor drivers are used. In this case, the space that is between 218H and 280H is used by the 21143 drivers. For applications that are not using DIGITAL Semiconductor drivers, the space that is between 218H and 3DFH can be used for tuples and for vendor-specific information. For information about the contents of the serial ROM, see the *DIGITAL Semiconductor 21X4 Serial ROM Format 4.02* at: <http://ftp.digital.com/pub/Digital/info/semiconductor/networks-and-communications/software/dsc-software-nc.html#support>

3.1 Configuration Operation

The 21143 enables a full software-driven initialization and configuration. This permits the software to identify and query the 21143.

The 21143 treats configuration space write operations to registers that are reserved as no-ops. That is, the access completes normally on the bus and the data is discarded. Read accesses, to reserved or unimplemented registers, complete normally and a data value of 0 is returned.

A software reset (CSR0<0>) has no effect on the configuration registers. A hardware reset and exit from the D3 power state sets the configuration registers to their default values.

The 21143 supports byte, word, and longword accesses to configuration registers.

Configuration Operation

3.1.1 Configuration Register Mapping

Table 3–1 lists the definitions and addresses for the configuration registers and Figure 3–2 shows the structure.

Table 3–1 Configuration Registers Mapping

Configuration Register	Identifier	I/O Address Offset
Identification	CFID	00H
Command and status	CFCS	04H
Revision	CFRV	08H
Latency timer	CFLT	0CH
Base I/O address	CBIO	10H
Base memory address	CBMA	14H
Reserved	—	18H–24H
Card information structure	CCIS	28H
Subsystem ID	CSID	2CH
Expansion ROM base address	CBER	30H
Capabilities Pointer ¹	CCAP	34H
Reserved	—	38H
Interrupt	CFIT	3CH
Device and Driver area	CFDD	40H
Configuration Wake-Up-LAN Address 0 (D, C, B, A)	CWUA0	44H
Configuration Wake-Up-LAN Address 1 (F, E)	CWUA1	48H
SecureON Password (D, C, B, A)	SOP0	4CH
SecureON Password (F, E)	SOP1	50H
Configuration Wake-Up Command	CWUC	54H
Reserved	—	58H–D8H
Capability ID ¹	CCID	DCH
Power Management Control and Status ¹	CPMC	E0H

¹This register only exists in the 21143–PD and the 21143–TD.

Figure 3–2 Configuration Register Structure

Device ID		Vendor ID		00H
Status		Command		04H
Class Code		Revision ID		08H
Reserved		Latency Timer	Cache Line Size	0CH
Base Address Register0–CBIO				10H
Base Address Register1–CBMA				14H
Reserved				18H–24H
CardBus CIS Pointer				28H
Subsystem ID		Subsystem Vendor ID		2CH
Expansion ROM Base Address				30H
Reserved		Capabilities Pointer		34H
Reserved				38H
Max_Lat	Min_Gnt	Interrupt Pin	Interrupt Line	3CH
Device and Driver Area				40H
Remote Wake-Up-LAN IEEE Address (D)	Remote Wake-Up-LAN IEEE Address (C)	Remote Wake-Up-LAN IEEE Address (B)	Remote Wake-Up-LAN IEEE Address (A)	44H
Reserved		Remote Wake-Up-LAN IEEE Address (F)	Remote Wake-Up-LAN IEEE Address (E)	48H
SecureON Password (D)	SecureON Password (C)	SecureON Password (B)	SecureON Password (A)	4CH
Reserved		SecureON Password (F)	SecureON Password (E)	50H
Remote Wake-Up-LAN Command		Remote Wake-Up-LAN Command		54H
Reserved				58H–D8H
Power Management Capabilities		Next Item Pointer	Capabilities Identification	DCH
Reserved		Power Management Control and Status		E0H

Configuration Operation

3.1.2 Standard Configuration Registers

The 21143 implements 13 standard configuration registers.¹ These registers are described in the following subsections.

3.1.2.1 Configuration ID Register (CFID—Offset 00H)

The CFID register identifies the 21143. Figure 3–3 shows the CFID register bit fields and Table 3–2 describes the bit fields.

Figure 3–3 CFID Register Bit Fields

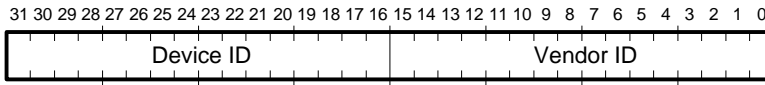

LJ-04696.WMF

Table 3–2 CFID Register Bit Fields Description

Field	Description
31:16	Device ID Provides the unique 21143 ID number (0019H).
15:0	Vendor ID Specifies the manufacturer of the 21143 (1011H).

Table 3–3 lists the access rules for the CFID register.

Table 3–3 CFID Register Access Rules

Category	Description
Value after hardware reset	00191011H
Read access rules	—
Write access rules	Writing has no effect.

¹The 21143–PB, 21143–TB, 21143–PC, and 21143–TC are implemented with 11 registers.

3.1.2.2 Command and Status Configuration Register (CFCS—Offset 04H)

The CFCS register is divided into two sections: a command register (CFCS<15:0>) and a status register (CFCS<31:16>).

The command register provides control of the 21143's ability to generate and respond to PCI cycles. When 0 is written to this register, the 21143 logically disconnects from the PCI bus for all accesses except configuration accesses.

The status register records status information for the PCI bus-related events. The CFCS status bits are not cleared when they are read. Writing 1 to these bits clears them; writing 0 has no effect. Some bits of this register are loaded from the serial ROM after a hardware reset. If the CFCS is addressed by the host before these bits are loaded from the serial ROM, the 21143 responds with a retry termination on the PCI bus.

Figure 3–4 shows the CFCS register bit fields.

Figure 3–4 CFCS Register Bit Fields

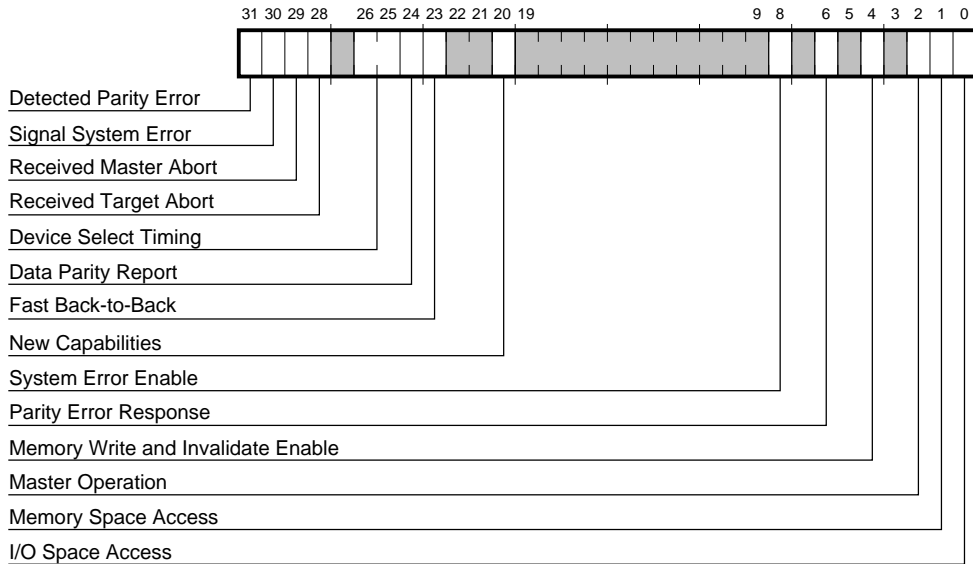

LJ-05202.A14

Configuration Operation

Table 3–4 describes the CFCS register bit fields.

Table 3–4 CFCS Register Bit Fields Description

(Sheet 1 of 2)

Field	Bit Type	Description
31	Status	Detected Parity Error When set, indicates that the 21143 detected a parity error, even if parity error handling is disabled in parity error response (CFCS<6>).
30	Status	Signal System Error When set, indicates that the 21143 asserted the system error serr_1 pin.
29	Status	Received Master Abort When set, indicates that the 21143 terminated a master transaction with master abort.
28	Status	Received Target Abort When set, indicates that the 21143 master transaction was terminated due to a target abort.
26:25	Status	Device Select Timing Indicates the timing of the assertion of device select (devsel_1). These bits are fixed at 01, which indicates a medium assertion of devsel_1 .
24	Status	Data Parity Report This bit sets when all of the following conditions are met: <ul style="list-style-type: none">• The 21143 asserts parity error perr_1 or it senses the assertion of perr_1 by another device.• The 21143 operates as a bus master for the operation that caused the error.• Parity error response (CFCS<6>) is set.
23	Status	Fast Back-to-Back Always set by the 21143. This indicates that the 21143 is capable of accepting fast back-to-back transactions that are not sent to the same bus device.
20	Status	New Capabilities¹ Indicates whether or not the 21143 implements a list of new capabilities. When set, this bit indicates the presence of New Capabilities. When cleared, New Capabilities are not implemented. The value of this bit is loaded from Func0_HwOptions<3> bit (PME_Enable) in the serial ROM.
8	Command	System Error Enable When set, the 21143 asserts system error (serr_1) when it detects a parity error on the address phase (ad<31:0> and c_be_1<3:0>).

Table 3–4 CFCS Register Bit Fields Description

(Sheet 2 of 2)

Field	Bit Type	Description
6	Command	<p>Parity Error Response</p> <p>When set, the 21143 asserts fatal bus error (CSR5<13>) after it detects a parity error.</p> <p>When reset, any detected parity error is ignored and the 21143 continues normal operation.</p> <p>Parity checking is disabled after a hardware reset.</p>
4	Command	<p>Memory Write and Invalidate Enable</p> <p>When set, the 21143 is allowed to generate the memory write and invalidate command.</p> <p>When reset, the 21143 capability to generate the memory write and invalidate command is disabled.</p>
2	Command	<p>Master Operation</p> <p>When set, the 21143 is capable of acting as a bus master.</p> <p>When reset, the 21143 capability to generate PCI accesses is disabled.</p> <p>For normal 21143 operation, this bit must be set.</p>
1	Command	<p>Memory Space Access</p> <p>When set, the 21143 responds to memory space accesses.</p> <p>When reset, the 21143 does not respond to memory space accesses.</p>
0	Command	<p>I/O Space Access</p> <p>When set, the 21143 responds to I/O space accesses.</p> <p>When reset, the 21143 does not respond to I/O space accesses.</p>

¹This feature is only supported in the 21143–PD and the 21143–TD.

Table 3–5 lists the access rules for the CFCS register.

Table 3–5 CFCS Register Access Rules

Category	Description
Value after hardware reset	02800000H
Read access rules	—
Write access rules	—

Configuration Operation

3.1.2.3 Configuration Revision Register (CFRV–Offset 08H)

The CFRV register contains the 21143 revision number. Figure 3–5 shows the CFRV register bit fields and Table 3–6 describes the bit fields.

Figure 3–5 21143 CFRV Register Bit Fields

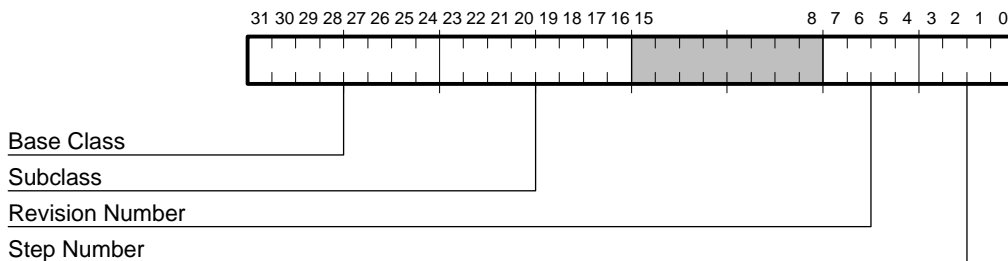

LJ03992B.WMF

Table 3–6 CFRV Register Bit Fields Description

Field	Description
31:24	Base Class Indicates the network controller and is equal to 2H.
23:16	Subclass Indicates the fast Ethernet controller and is equal to 0H.
7:4	Revision Number Indicates the 21143 revision number.
3:0	Step Number Indicates the 21143 step number within the current revision.

Table 3–7 lists the revision and step numbers for each variant of the device.

Table 3–7 21143 Revision and Step Number

(Sheet 1 of 2)

Device	Revision Number	Step Number
21143–PB	3	0
21143–TB	3	0
21143–PC	3	0

Table 3–7 21143 Revision and Step Number

(Sheet 2 of 2)

Device	Revision Number	Step Number
21143–TC	3	0
21143–PD	4	1
21143–TD	4	1

Table 3–8 lists the access rules for the CFRV register.

Table 3–8 CFRV Register Access Rules

Category	Description
Value after hardware reset	Device specific, see Table 3–7.
Read access rules	—
Write access rules	Writing has no effect.

3.1.2.4 Configuration Latency Timer Register (CFLT–Offset 0CH)

This register configures the cache line size field and the 21143 latency timer.

Figure 3–6 shows the CFLT bit field and Table 3–9 describes the CFLT bit field.

Figure 3–6 CFLT Configuration Latency Timer Register

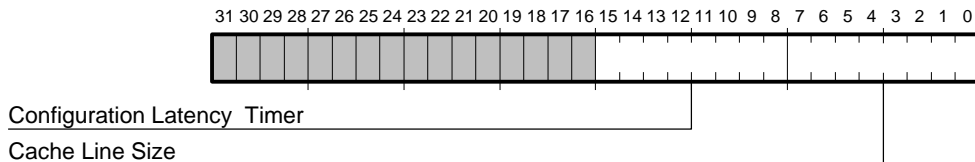

LJ-05019.WMF

Configuration Operation

Table 3–9 CFLT Register Bit Fields Description

Field	Description
15:8	Configuration Latency Timer Specifies, in units of PCI bus clocks, the value of the latency timer of the 21143. When the 21143 asserts frame_1 , it enables its latency timer to count. If the 21143 deasserts frame_1 prior to count expiration, the content of the latency timer is ignored. Otherwise, after the count expires, the 21143 initiates transaction termination as soon as its gnt_1 is deasserted.
7:0	Cache Line Size Specifies, in units of 32-bit words, the system cache line size. The 21143 supports cache line sizes of 8, 16 and 32 longwords. If an attempt is made to write an unsupported value to this register, the 21143 behaves as if a value of zero was written. The driver should use the value of the cache line size to program the cache alignment bits (CSR0<15:14>). The 21143 uses the cache alignment bits for PCI commands that are cache oriented, such as memory-read-line, memory-read-multiple and memory-write-and-invalidate.

Table 3–10 lists the access rules for the CFLT register.

Table 3–10 CFLT Access Rules

Category	Description
Value after hardware reset	0H
Read access rules	—
Write access rules	—

3.1.2.5 Configuration Base I/O Address Register (CBIO–Offset 10H)

The CBIO register specifies the base I/O address for accessing the 21143 CSRs (CSR0–15). For example, if the CBIO register is programmed to 1000H, the I/O address of CSR15 is equal to CBIO + CSR15-offset for a value of 1078H (Table 3–41).

This register must be initialized prior to accessing any CSR with I/O access.

Figure 3–7 shows the CBIO register bit fields and Table 3–11 describes the bit fields.

Figure 3–7 CBIO Register Bit Fields

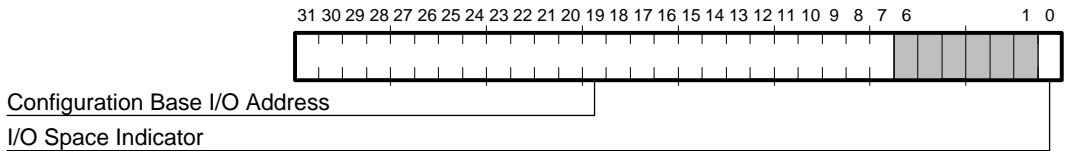

LJ03987A.WMF

Table 3–11 CBIO Register Bit Fields Description

Field	Description
31:7	Configuration Base I/O Address Defines the base address assigned for mapping the 21143 CSRs.
6:1	This field value is 0 when read.
0	I/O Space Indicator Determines that the register maps into the I/O space. The value in this field is 1. This is a read-only field.

Table 3–12 lists the access rules for the CBIO register.

Table 3–12 CBIO Register Access Rules

Category	Description
Value after hardware reset	Undefined
Read access rules	—
Write access rules	—

3.1.2.6 Configuration Base Memory Address Register (CBMA–Offset 14H)

The CBMA register specifies the base memory address for memory accesses to the 21143 structures. The CBMA maps 18 21143-specific CSRs, 4 CardBus Status Changed registers, and the serial ROM.

This register must be initialized prior to accessing any CSR with memory access.

Configuration Operation

Figure 3–8 shows the CBMA register bit fields and Table 3–13 describes the bit fields.

Figure 3–8 CBMA Register Bit Fields

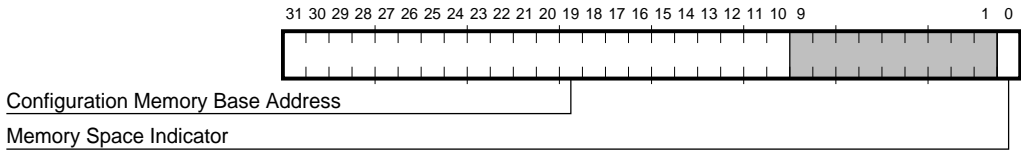

LJ-04734.A14

Table 3–13 CBMA Register Bit Fields Description

Field	Description
31:10	Configuration Base Memory Address Defines the base address assigned for mapping the 21143 CSRs.
9:7	For the 21143–PD and the 21143–TD, this field value is 0 when read. For the 21143–PB, 21143–TB, 21143–PC, and the 21143–TC, these bits are the least significant bits of the configuration base memory address.
6:1	This field value is 0 when read.
0	Memory Space Indicator Determines that the register maps into the memory space. The value in this field is 0. This is a read-only field.

Table 3–14 lists the access rules for the CBMA register.

Table 3–14 CBMA Register Access Rules

Category	Description
Value after hardware reset	Undefined
Read access rules	—
Write access rules	—

3.1.2.7 Configuration Card Information Structure Register (CCIS–Offset 28H)

The CCIS register is a read-only 32-bit register. This register points to one of the possible address spaces where the card information structure (CIS) begins. The pointer is used in a CardBus PC card environment. The content of the CCIS is loaded from the serial ROM after a hardware reset. If the CCIS is accessed by the

host before its content is loaded from the serial ROM, the 21143 responds with retry termination on the PCI bus. A value of 0 in this register indicates that CIS is not supported.

Figure 3–9 shows the CCIS register bit fields and Table 3–15 describes the bit fields.

Figure 3–9 CCIS Register Bit Fields

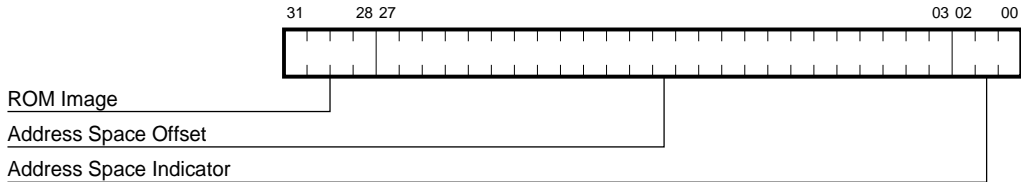

LJ-04487.A15

Table 3–15 CCIS Register Bit Fields Description

Field	Description
31:28	ROM Image The 4-bit ROM image field value when the CIS resides in an expansion ROM.
27:3	Address Space Offset This field contains the address offset within the address space indicated by the address space indicator field (CCIS<2:0>).
2:0	Address Space Indicator This field indicates the location of the CIS base address. The 21143 supports the value of 2, indicating that the CIS is stored in the serial ROM, and 7, indicating that the CIS is stored in the expansion ROM. Any value other than 2 or 7 may lead to unpredictable behavior.

Table 3–16 lists the access rules for the CCIS register.

Configuration Operation

Table 3–16 CCIS Register Access Rules

Category	Description
Value after hardware reset	Read from serial ROM.
Read access rules	—
Write access rules	Write has no effect on 21143.

3.1.2.8 Subsystem ID Register (CSID–Offset 2CH)

The CSID register is a read-only 32-bit register. The content of the CSID is loaded from the serial ROM after a hardware reset. If the CSID is accessed by the host before its content is loaded from the serial ROM, the 21143 responds with retry termination on the PCI bus. The value is 0 if the serial ROM data integrity check fails.

Figure 3–10 shows the CSID register bit fields and Table 3–17 describes the bit fields.

Figure 3–10 CSID Register Bit Fields

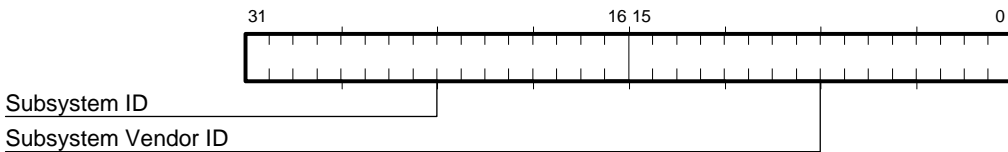

LJ-04499.WMF

Table 3–17 CSID Register Bit Fields Description

Field	Description
31:16	Subsystem ID A 16-bit field containing the subsystem ID.
15:0	Subsystem Vendor ID A 16-bit field containing the subsystem vendor ID.

Table 3–18 lists the access rules for the CSID register.

Table 3–18 CSID Register Access Rules

Category	Description
Value after hardware reset	Read from serial ROM.
Read access rules	—
Write access rules	Write has no effect on 21143.

3.1.2.9 Expansion ROM Base Address Register (CBER–Offset 30H)

The CBER register specifies the expansion ROM base address and provides information about the expansion ROM size. This register must be initialized prior to accessing the expansion ROM with Dword access (see Section 8.3).

Figure 3–11 shows the CBER register bit fields and Table 3–19 describes the bit fields.

Figure 3–11 CBER Register Bit Fields

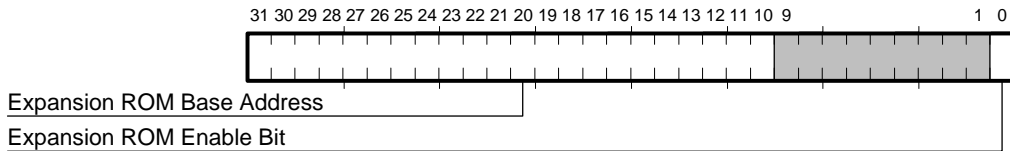

LJ03971A.WMF

Table 3–19 CBER Register Bit Fields Description

Field	Description
31:10	Expansion ROM Base Address Defines the base address assigned for mapping the expansion ROM. It also provides information about the expansion ROM size. CBER<17:10> are hardwired to 0, indicating that the expansion ROM size is up to 256KB.
9:1	This field value is 0 when read.
0	Expansion ROM Enable Bit The 21143 responds to its expansion ROM accesses only if the memory space access bit (CFCS<1>) and the expansion ROM enable bit are both set to 1.

Table 3–20 lists the access rules for the CBER register.

Configuration Operation

Table 3–20 CBER Register Access Rules

Category	Description
Value after hardware reset	XXXX0000H
Read access rules	—
Write access rules	—

3.1.2.10 Capabilities Pointer (CCAP–Offset 34H)

The CCAP register has a pointer to the power-management register block in the PCI configuration space.¹ This pointer is valid only if the new capabilities bit in CFCS is set.

Figure 3–12 shows the CCAP register bit fields and Table 3–21 describes the bit fields.

Figure 3–12 CCAP Register Bit Fields

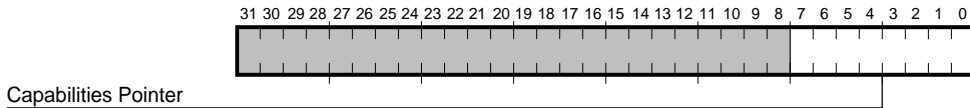

FM-06207.AI4

Table 3–21 CCAP Register Bit Fields Description

Field	Description
7:0	<p>Capabilities Pointer</p> <p>Points to the location of the power-management register block in the PCI configuration space.</p> <p>The value of this field is determined by Func0_HwOptions<3> bit (PME_Enable) in the serial ROM.</p> <p>If this bit is set, the value of this field is DCH; otherwise, this field is read as 00H.</p>

Table 3–22 lists the access rules for the CCAP register.

¹This register only exists on the 21143–PD and the 21143–TD.

Table 3–22 CCAP Register Access Rules

Category	Description
Value after hardware reset	000000DCH or 00000000H ¹
Read access rules	—
Write access rules	—

¹According to Func0_HwOptions<3> (PME_Enable) in the serial ROM.

3.1.2.11 Configuration Interrupt Register (CFIT–Offset 3CH)

The CFIT register is divided into two sections: the interrupt line and the interrupt pin. CFIT configures both the system’s interrupt line and the 21143 interrupt pin connection. Figure 3–13 shows the CFIT register bit fields.

Figure 3–13 CFIT Register Bit Fields

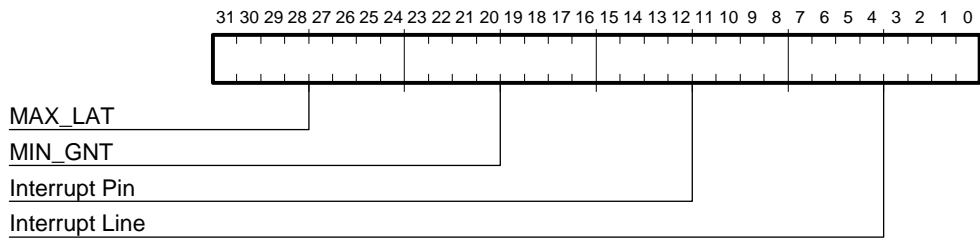

LJ-04701.WMF

Table 3–23 describes the CFIT register bit fields.

Table 3–23 CFIT Register Bit Fields Description

(Sheet 1 of 2)

Field	Description
31:24	MAX_LAT This field indicates how often the device needs to gain access to the PCI bus. Time unit is equal to 0.25 μ s, assuming a PCI clock frequency of 33 MHz. The value after a hardware reset is 28H (10 μ s).
23:16	MIN_GNT This field indicates the burst period length that the device needs. Time unit is equal to 0.25 μ s, assuming a PCI clock frequency of 33 MHz. The value after a hardware reset is 14H (5 μ s).
15:8	Interrupt Pin Indicates which interrupt pin the 21143 uses. The 21143 uses INTA# and the read value is 01H.

Configuration Operation

Table 3–23 CFIT Register Bit Fields Description

(Sheet 2 of 2)

Field	Description
7:0	Interrupt Line Provides interrupt line routing information. The basic input/output system (BIOS) writes the routing information into this field when it initializes and configures the system. The value in this field indicates which input of the system interrupt controller is connected to the 21143's interrupt pin. The driver can use this information to determine priority and vector information. Values in this field are system architecture specific.

Table 3–24 lists the access rules for the CFIT register.

Table 3–24 CFIT Register Access Rules

Category	Description
Value after hardware reset	281401XXH
Read access rules	—
Write access rules	—

3.1.2.12 Capability ID Register (CCID–Offset DCH)

The CCID register is a read-only register that provides information on the 21143 power-management capabilities.¹ Figure 3–14 shows the CCID register.

¹This register only exists on the 21143–PD and the 21143–TD.

Figure 3–14 CCID Register Bit Fields

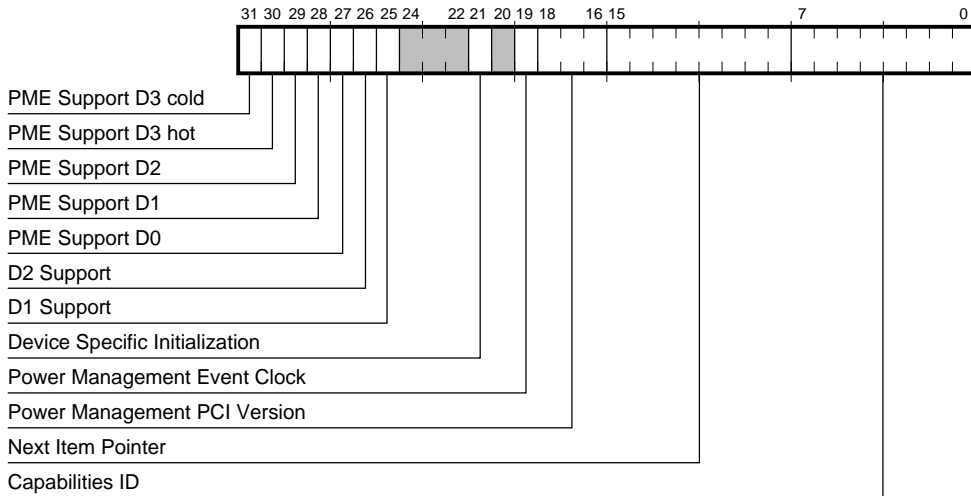

FM-06228.A14

Table 3–25 describes the CCID register bit fields.

Table 3–25 CCID Register Bit Fields Description

(Sheet 1 of 2)

Field	Description
31	<p>PME Support D3_{cold}</p> <p>If this bit is set, the 21143 asserts PME in D3_{cold} power state. Otherwise, the 21143 does not assert PME in D3_{cold}. The value of this bit is loaded from Func0_HwOptions<6> bit in the serial ROM.</p>
30	<p>PME Support D3_{hot}</p> <p>The value of this field is 1, indicating that the 21143 may assert PME in D3_{hot} power state.</p>
29	<p>PME Support D2</p> <p>The value of this field is 1, indicating that the 21143 may assert PME in D2 power state.</p>
28	<p>PME Support D1</p> <p>The value of this field is 1, indicating that the 21143 may assert PME in D1 power state.</p>

Configuration Operation

Table 3–25 CCID Register Bit Fields Description

(Sheet 2 of 2)

Field	Description
27	PME Support D0 The value of this field is 0, indicating that the 21143 does not assert PME in D0 power state.
26	D2 Support The value of this field is 1, indicating that the 21143 supports the D2 power state.
25	D1 Support The value of this field is 1, indicating that the 21143 supports the D1 power state.
21	Device Specific Initialization The value of this field is 0, indicating that the 21143 does not require a special initialization code sequence in order to be configured correctly.
19	Power Management Event Clock The value of this field is 0, indicating that the 21143 does not rely on the presence of the CardBus clock in order to generate a PME.
18:16	Power Management PCI Version The value of this field is 001BH, indicating that the 21143 complies with revision 1 of the <i>PCI Power Management Specification</i> .
15:8	Next Item Pointer Points to the location of the next block of the capability list in the PCI Configuration Space. The value of this field is 00H, indicating that this is the last item of the Capability linked list.
7:0	Capabilities ID PCI Power Management Registers ID. The value of this field is 01h, indicating that this is the power-management register block.

Table 3–26 lists the access rules for the CCID register.

Table 3–26 CCID Register Access Rules

Category	Description
Value after reset	F601000H ¹
Read access rules	—
Write access rules	Write has no effect on 21143.

¹According to Func0_HwOptions<6> (OnNowD3ColdCap) in the serial ROM.

3.1.2.13 Power-Management Control and Status Register (CPMC–Offset E0H)

The CPMC register is used to manage the 21143 device power state, and to enable and monitor the 21143 power-management events.¹

Figure 3–15 shows the CPMC register.

Figure 3–15 CPMC Register Bit Fields

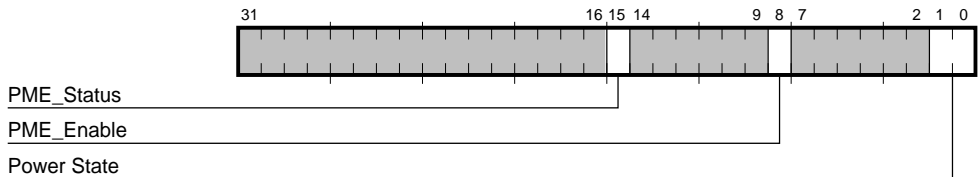

FM-06222.A14

Table 3–27 describes the CPMC register bit fields.

Table 3–27 CPMC Register Bit Fields Description

(Sheet 1 of 2)

Field	Description
15	<p>PME_Status</p> <p>This bit indicates that the 21143 has detected a power-management event. If bit PME_Enable is set, the 21143 also asserts the gcp<2>/rcv_match/wake pin. This bit is cleared on power-up reset or by write 1. It is not modified by either hardware or software reset.</p> <p>When this bit is cleared, the 21143 deasserts the gcp<2>/rcv_match/wake pin.</p> <p>Note: This bit is also cleared if the General Enable bit of the Function Event Register (Function Event Register<4>) is cleared.</p>

¹This register only exists on the 21143–PD and the 21143–TD.

Configuration Operation

Table 3–27 CPMC Register Bit Fields Description

(Sheet 2 of 2)

Field	Description
8	PME_Enable If this bit is set, the 21143 can assert the gcp<2>/rcv_match/wake pin. Otherwise, assertion of the gcp<2>/rcv_match/wake pin by the 21143 is disabled. This bit is cleared on power-up reset only and is not modified by either hardware or software reset.
1:0	Power State This field is used to set the current power state of the 21143 and to determine its power state. The definitions of the field values are: 0 - D0 1 - D1 2 - D2 3 - D3 _{hot} This field gets a value of 0 after power-up.

Table 3–28 lists the access rules for the CPMC register.

Table 3–28 CPMC Register Access Rules

Category	Description
Value after reset	00000000H
Read access rules	—
Write access rules	—

3.1.3 21143-Specific Configuration Registers

The 21143 implements six 21143-specific configuration registers. These registers are described in the following subsections.

3.1.3.1 Configuration Device and Driver Area Register (CFDD—Offset 40H)

The CFDD register can be used to store driver-specific information and to control the 21143 power-saving mode.

Figure 3–16 shows the CFDD register bit fields.

Figure 3–16 CFDD Register Bit Fields

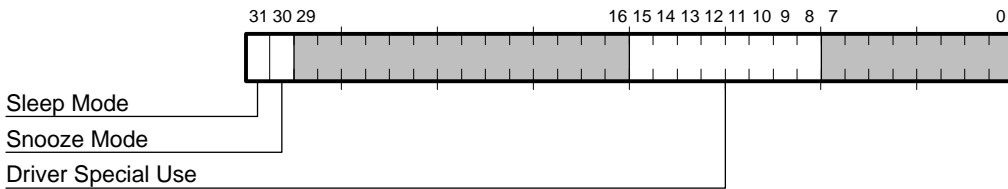

LJ03986A.WMF

Table 3–29 describes the CFFD register bit.

Table 3–29 CFDD Register Bit Fields Description

Field	Description
31	<p>Sleep Mode</p> <p>When this bit is set, the 21143 enters sleep mode and most of its internal clocks are disconnected. While in sleep mode, the 21143 can only be accessed through its configuration space. The 21143 also allows the clock to be stopped through <code>clkrun</code> while in sleep mode. The 21143 temporarily exits sleep mode upon hardware reset. When this bit is reset, a permanent exit from sleep mode is accomplished. Note that this bit must <i>not</i> be asserted together with bit 30 (snooze mode) in this register.</p>
30	<p>Snooze Mode</p> <p>When this bit is set, the 21143 enters snooze mode. In this mode, most of the clocks are disconnected when they are not needed. When the 21143 needs the clocks, it temporarily connects the clocks, until the event that caused the clocks to reconnect is completed. For more information, see Section 7.4.2.</p> <p>While in snooze mode, the 21143 allows the PCI/CardBus clock to be stopped through <code>clkrun</code>, if it is not needed.</p> <p>When this bit is reset, the 21143 exits snooze mode. Note that this bit must <i>not</i> be asserted together with bit 31 (sleep mode) in this register.</p>
15:8	<p>Driver Special Use</p> <p>Specifies read and write fields for the driver’s special use.</p>

Table 3–30 lists the access rules for the CFDD register.

Table 3–30 CFDD Register Access Rules

Category	Description
Value after hardware reset	8000XX00H
Read access rules	—
Write access rules	—

Configuration Operation

3.1.3.2 Configuration Wake-Up-LAN IEEE Address Registers (CWUA0–Offset 44H, CWUA1–Offset 48H)

The CWUA0 and CWUA1 are write-only registers that contain the remote wake-up-LAN IEEE address. These registers use a naming convention of A-B-C-D-E-F, with “A” representing the first byte of the remote wake-up-LAN IEEE address that is received on the Ethernet wire (for an example, see Appendix F).

The wake-up-LAN IEEE address is used as the 21143 address in remote wake-up-LAN mode. These registers are loaded from the Magic block in the serial ROM when the 21143 transitions from the D0 power state to any other power state, and when the 21143 enters the remote wake-up-LAN mode. Writing to these registers overrides the value that was loaded from the serial ROM. If these registers are accessed by the host before the remote wake-up-LAN IEEE parameters are loaded from the serial ROM, the 21143 responds with a retry termination on the PCI bus.

Figure 3–17 shows the CWUA0 register.

Figure 3–17 CWUA0 Register Bit Fields

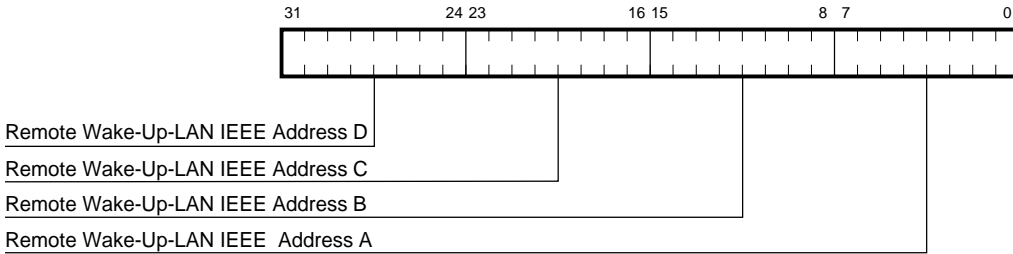

FM-05977.AI4

Table 3–31 describes the CWUA0 register bit fields.

Table 3–31 CWUA0 Register Bit Fields Description

(Sheet 1 of 2)

Category	Description
31:24	Remote Wake-Up-LAN IEEE Address D Defines one byte of the remote wake-up-LAN IEEE address.
23:16	Remote Wake-Up-LAN IEEE Address C Defines one byte of the remote wake-up-LAN IEEE address.
15:8	Remote Wake-Up-LAN IEEE Address B Defines one byte of the remote wake-up-LAN IEEE address.

Table 3–31 CWUA0 Register Bit Fields Description

(Sheet 2 of 2)

Category	Description
7:0	Remote Wake-Up-LAN IEEE Address A Defines the first byte of the remote wake-up-LAN IEEE address.

Table 3–32 lists the access rules for the CWUA0 register.

Table 3–32 CWUA0 Register Access Rules

Category	Description
Value after reset	Undefined
Read access rules	This is a write-only register.
Write access rules	—

Figure 3–18 shows the CWUA1 register.

Figure 3–18 CWUA1 Register Bit Fields

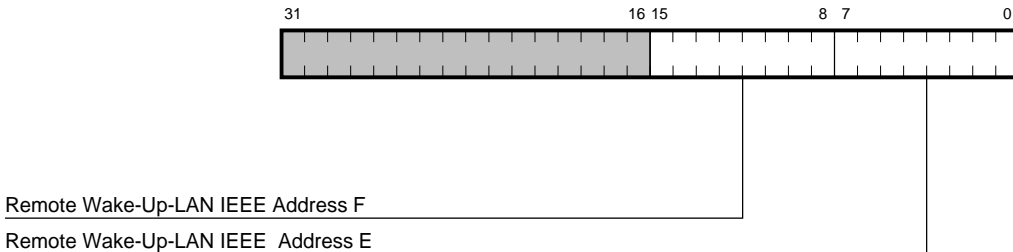

FM-05979.A14

Table 3–33 describes the CWUA1 register bit fields.

Table 3–33 CWUA1 Register Bit Fields Description

Category	Description
15:8	Remote Wake-Up-LAN IEEE Address F Defines one byte of the remote wake-up-LAN IEEE address.
7:0	Remote Wake-Up-LAN IEEE Address E Defines the last byte of the remote wake-up-LAN IEEE address.

Configuration Operation

Table 3–34 lists the access rules for the CWUA1 register.

Table 3–34 CWUA1 Register Access Rules

Category	Description
Value after reset	Undefined
Read access rules	This is a write-only register.
Write access rules	—

3.1.3.3 SecureON™ Password Registers (SOP0–Offset 4CH, SOP1–Offset 50H)

The SOP0 and SOP1 are write-only registers that contain the SecureON password. This password is compared to the password in the Magic Packet for validation while the 21143 is in remote wake-up-LAN mode. These registers use a naming convention of A-B-C-D-E-F, with “A” representing the first byte of the remote wake-up-LAN password that is received on the Ethernet wire (for an example, see Appendix F).

These registers are loaded when the 21143 transitions from the D0 power state to any other power state, and when the 21143 enters the remote wake-up-LAN mode. Writing to these registers overrides the value that was loaded from the serial ROM. If these registers are accessed by the host before the remote wake-up-LAN IEEE parameters are loaded from the serial ROM, the 21143 responds with a retry termination on the PCI bus.

Figure 3–19 shows the SOP0 register.

Figure 3–19 SOP0 Register Bit Fields

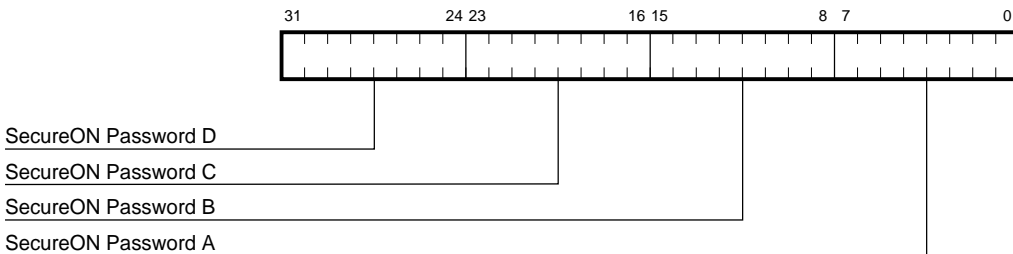

FM-05980.A14

Table 3–35 describes the SOP0 register bit fields.

Table 3–35 SOP0 Register Bit Fields Description

Field	Description
31:24	SecureON Password D Defines one byte of the SecureON password.
23:16	SecureON Password C Defines one byte of the SecureON password.
15:8	SecureON Password B Defines one byte of the SecureON password.
7:0	SecureON Password A Defines the first byte of the SecureON password.

Table 3–36 lists the access rules for the SOP0 register.

Table 3–36 SOP0 Register Access Rules

Category	Description
Value after reset	Undefined
Read access rules	Read as zero
Write access rules	—

Figure 3–20 shows the SOP1 register.

Figure 3–20 SOP1 Register Bit Fields

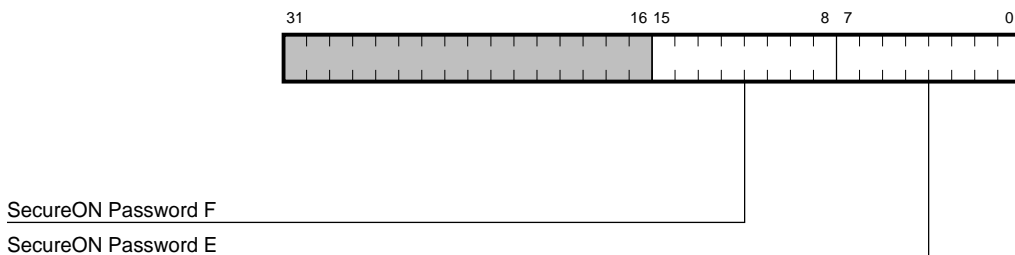

FM-05978.A14

Configuration Operation

Table 3–37 describes the SOP1 register bit fields.

Table 3–37 SOP1 Register Bit Fields Description

Field	Description
15:8	SecureON Password F Defines one byte of the SecureON password.
7:0	SecureON Password E Defines the last byte of the SecureON password.

Table 3–38 lists the access rules for the SOP1 register.

Table 3–38 SOP1 Register Access Rules

Category	Description
Value after reset	Undefined
Read access rules	Read as zero
Write access rules	—

3.1.3.4 Configuration Wake-Up Command Register (CWUC–Offset 54H)

The CWUC controls the remote wake-up-LAN feature. The CWUC is loaded from the serial ROM when remote wake-up-LAN mode is entered. Writing to this register overrides the value that was loaded from the serial ROM. If the CWUC is accessed by the host before the remote wake-up-LAN parameters are loaded from the serial ROM, the 21143 responds with a retry termination on the PCI bus.

Figure 3–21 shows the CWUC register.

Figure 3–21 CWUC Register Bit Fields

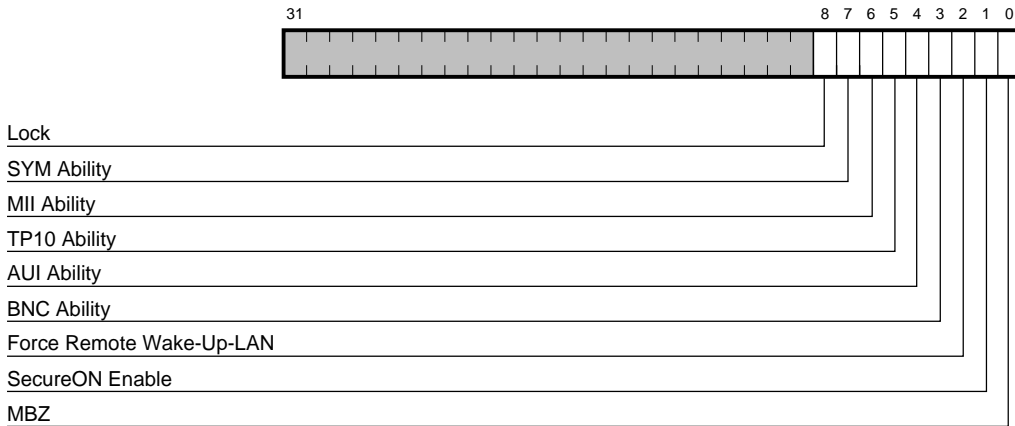

FM-05635.AI4

Table 3–39 describes the CWUC register bit fields.

Table 3–39 CWUC Register Bit Fields Description

(Sheet 1 of 2)

Field	Description
8	<p>Lock</p> <p>If set to 1:</p> <ul style="list-style-type: none"> • Remote wake-up-LAN command register is disabled for writes and reads all 1s. • Remote wake-up-LAN IEEE address register and SecureON password register are disabled for writes. <p>The 21143 exits from the Lock state only in a hardware reset.</p>
7	<p>SYM Ability¹</p> <p>When set, indicates that the 21143 is connected to a symbol PHY device. The remote wake-up-LAN mode attempts autosensing on the SYM PHY port and enables autonegotiation</p>
6	<p>MII Ability</p> <p>When set, indicates that the 21143 is connected to an MII PHY device. The remote wake-up-LAN mode selects the MII PHY port.</p>

Configuration Operation

Table 3–39 CWUC Register Bit Fields Description

(Sheet 2 of 2)

Field	Description
5	TP10 Ability² When set, indicates that the 21143 is connected to the twisted pairs. The remote wake-up-LAN mode attempts autosensing on TP 10 Mb/s and enables autonegotiation.
4	AUI Ability When set, indicates that the 21143 is connected to an AUI. The remote wake-up-LAN mode attempts autosensing on the AUI.
3	BNC Ability³ When set, indicates that the 21143 is connected to the BNC. The remote wake-up-LAN mode attempts autosensing on the BNC.
2	Force Remote Wake-Up-LAN When set, forces the 21143 into remote wake-up-LAN mode. Usually, the 21143 enters remote wake-up-LAN mode by sensing power-supply conditions. This bit is used for engineering purposes.
1	SecureON Enable When set, enables the password-security feature for Magic Packet and the attack-limiter circuit.
0	MBZ This bit must not be written with a value of one. ⁴

¹The **mii_mdio** pin (pin 135) should be tied to **Vss** when not in MII mode.

²If no PHY device is connected to the MII/SYM port, the **sd** pin (pin 117) should be tied to **Vss** in order to make the link-integrity test operate properly.

³If BNC is selected when in remote wake-up-LAN mode, pin **gcp<0>** will be set to enable the external BNC transceiver. It will be set regardless of the values in CSR15<20> (LED/GEP 0 Select) and CSR15<3> (AUI/BNC Mode).

⁴The remote wake-up LAN is disabled when this bit is set for the 21143–PB, 21143–TB, 21143–PC, and the 21143–TC.

Table 3–40 lists the access rules for the CWUC register.

Table 3–40 CWUC Register Access Rules

Category	Description
Value after reset	00000000H
Read access rules	—
Write access rules	CWUC<2> may be set only when receive and transmit processes are stopped.

3.2 CSR Operation

The 21143 CSRs are mapped into the host I/O or the host memory address space. The CSRs are *quadword* aligned, 32 bits long, and must be accessed using *longword* instructions with quadword-aligned addresses only.

Note: Reserved bits are shaded and should be written with 0. Failing to do this could cause incompatibility problems with a future version of the 21143. Reserved bits are undefined on read access.

Retries on second data transactions occur in response to burst accesses.

CSRs are physically located in the chip. The host uses a single instruction to access a CSR.

All CSRs are set to their default values by either a hardware or a software reset unless otherwise specified.

CSR Operation

3.2.1 Control and Status Register Mapping

Table 3–41 lists the definitions and addresses for the CSR registers.

Table 3–41 CSR Mapping

Register	Meaning	Offset from CSR Base Address (CBIO and CBMA)
CSR0	Bus mode	00H
CSR1	Transmit poll demand	08H
CSR1-PM	Wake-up frame filter control	08H
CSR2	Receive poll demand	10H
CSR2-PM	Wake-up events control and status	10H
CSR3	Receive list base address	18H
CSR4	Transmit list base address	20H
CSR5	Status	28H
CSR6	Operation mode	30H
CSR7	Interrupt enable	38H
CSR8	Missed frames and overflow counter	40H
CSR9	Boot ROM, serial ROM, and MII management	48H
CSR10	Boot ROM programming address	50H
CSR11	General-purpose timer and interrupt mitigation control	58H
CSR12	SIA status	60H
CSR13	SIA connectivity	68H
CSR14	SIA transmit and receive	70H
CSR15	SIA and general-purpose port	78H

3.2.2 Host CSRs

The 21143 implements 18 CSRs (CSR0 through CSR15, plus CSR1-PM and CSR2-PM), which can be accessed by the host.

3.2.2.1 Bus Mode Register (CSR0–Offset 00H)

CSR0 establishes the bus operating modes. Figure 3–22 shows the CSR0 bit fields.

Figure 3–22 CSR0 Bus Mode Register

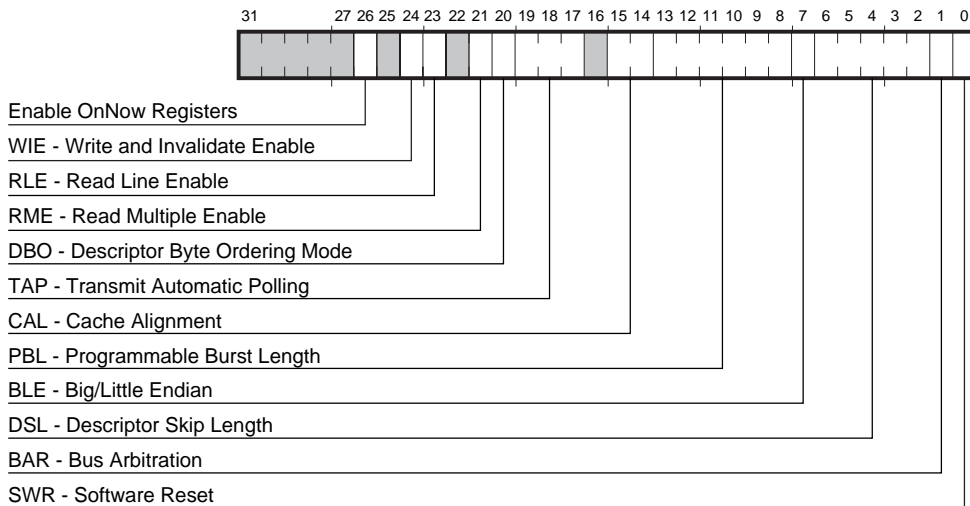

LJ-05020.AI4

Table 3–42 describes the CSR0 bit fields.

Table 3–42 CSR0 Register Bit Fields Description

(Sheet 1 of 3)

Field	Description
26	<p>Enable OnNow Registers¹</p> <p>When set, CSR1-PM and CSR2-PM are accessible. When this bit is cleared, writing to these registers is interpreted as writing to CSR1 and CSR2 (receive/transmit poll demand). This bit is cleared upon hardware and software reset.</p>

CSR Operation

Table 3–42 CSR0 Register Bit Fields Description

(Sheet 2 of 3)

Field	Description
24	WIE—Write and Invalidate Enable When set, the 21143 supports the memory-write-and-invalidate command on the PCI bus. The 21143 uses the memory-write-and-invalidate command while writing full cache lines. While writing partial cache lines, the 21143 uses the memory-write command. Descriptors are also written using the memory-write command. When this field is reset, the memory-write command is used for write access. This bit is effective only if CFCS<4> is set.
23	RLE—Read Line Enable When set, the 21143 supports the memory-read-line command on the PCI bus. Read access instructions that reach the cache-line boundary use the memory-read-line command. Read access instructions that do not reach the cache-line boundary use the memory-read command. This field operates in conjunction with the read multiple enable (CSR0<21>) field.
21	RME—Read Multiple Enable When set, the 21143 supports the memory-read-multiple command on the PCI bus. The 21143 uses the memory-read-multiple command while reading full cache lines. If the memory buffer is not cache aligned, the 21143 uses a memory-read command to read up to the cache line boundary. The 21143 then uses a memory-read-multiple command for reading an integer number of cache lines. If read line enable (CSR0<23>) is also set, the 21143 uses the memory-read-line command to align the memory buffer to the cache line. Read transactions that do not reach the cache line boundary use the memory-read command. The memory-read command is used to read descriptors.
20	DBO—Descriptor Byte Ordering Mode When set, the 21143 operates in big endian ordering mode for descriptors only. When reset, the 21143 operates in little endian mode.
19:17	TAP—Transmit Automatic Polling When set and the 21143 is in a suspended state because a transmit buffer is unavailable, the 21143 performs a transmit automatic poll demand (Table 3–43). This feature is not active in snooze mode.
15:14	CAL—Cache Alignment Programmable address boundaries for data burst stop (Table 3–45). If the buffer is not aligned, the 21143 executes the first transfer up to the address boundary. Then, all transfers are aligned to the specified boundary. When read line enable (CSR0<23>) is set, this field should be equal to the system cache line size (CFLT<7:0>). When write and invalidate enable (CSR0<24>) is set and read line enable (CSR0<23>) is reset, the cache alignment field should be equal to or a multiple of the system cache line size.

Table 3–42 CSR0 Register Bit Fields Description

(Sheet 3 of 3)

Field	Description
13:8	<p>PBL—Programmable Burst Length</p> <p>Indicates the maximum number of longwords to be transferred in one DMA transaction. If reset, the 21143 burst is limited only by the amount of data stored in the receive FIFO (at least 16 longwords), or by the amount of free space in the transmit FIFO (at least 16 longwords) before issuing a bus request. When read line enable (CSR0<23>) or write and invalidate enable (CSR0<24>) are set, the programmable burst length (CSR0<13:8>) should be greater than or equal to the system cache line size (CFLT<7:0>). The PBL can be programmed with permissible values 0, 1, 2, 4, 8, 16, or 32. After reset, the PBL default value is 0.</p>
7	<p>BLE—Big/Little Endian</p> <p>When set, the 21143 operates in big endian byte ordering mode. When reset, the 21143 operates in little endian byte ordering mode. Big endian is only applicable for data buffers. For example, the byte order in little endian of a data buffer is 12345678H, with each digit representing a nibble. In big endian, the byte orientation is 78563412H.</p>
6:2	<p>DSL—Descriptor Skip Length</p> <p>Specifies the number of longwords to skip between two unchained descriptors.</p>
1	<p>BAR—Bus Arbitration</p> <p>Selects the internal bus arbitration between the receive and transmit processes. When set, a round-robin arbitration scheme is applied resulting in equal sharing between processes. When reset, the receive process has priority over the transmit process, unless the 21143 is currently transmitting (Section 4.3.5).</p>
0	<p>SWR—Software Reset</p> <p>When set, the 21143 resets all internal hardware with the exception of the configuration area; it does not change the port select setting (CSR6<18>).</p>

[†]This bit only exists on the 21143–PD and the 21143–TD.

CSR Operation

Table 3–43 defines the transmit automatic polling bits and lists the automatic polling intervals for MII 10/100-Mb/s and SRL modes.

Table 3–43 Transmit Automatic Polling Intervals

CSR0<19:17>	Polling Interval		
	10BASE-T/AUI	10-Mb/s MII/SYM	100-Mb/s MII/SYM
000	TAP Disabled	TAP Disabled	TAP Disabled
001	200 μ s	800 μ s	80 μ s
010	600 μ s	2.4 ms	240 μ s
011	1.4 ms	5.6 ms	560 μ s
100	12.8 μ s	51.2 μ s	5.12 μ s
101	25.6 μ s	102.4 μ s	10.24 μ s
110	38.4 μ s	153.6 μ s	15.36 μ s
111	89.6 μ s	358.4 μ s	35.84 μ s

Table 3–44 lists the access rules for the CSR0 register.

Table 3–44 CSR0 Access Rules

Category	Description
Value after reset	FE00000H
Read access rules	—
Write access rules	To write, the transmit and receive processes must be stopped. If one or both of the processes is not stopped, the result is UNPREDICTABLE .

Table 3–45 defines the cache address alignment bits.

Table 3–45 Cache Alignment Bits

CSR0<15:14>	Address Alignment
00	No cache alignment
01	8-longword boundary alignment
10	16-longword boundary alignment
11	32-longword boundary alignment

3.2.2.2 Transmit Poll Demand Register (CSR1–Offset 08H)

CSR1 is used by the driver to instruct the 21143 to poll the transmit descriptor list. Figure 3–23 shows the CSR1 register bit field and Table 3–46 describes the bit field.

Figure 3–23 CSR1 Register Bit Field

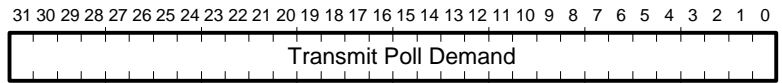

LJ-04704.WMF

Table 3–46 CSR1 Register Bit Field Description

Field	Description
31:0	TPD–Transmit Poll Demand (Write Only) When written with any value, the 21143 checks for frames to be transmitted. If no descriptor is available, the transmit process returns to the suspended state and CSR5<2> is not asserted. If the descriptor is available, the transmit process resumes.

Table 3–47 lists the access rules for the CSR1 register.

Table 3–47 CSR1 Register Access Rules

Category	Description
Value after reset	FFFFFFFFH
Read access rules	—
Write access rules	This register can be written only when the CSR0<26> bit is cleared.

CSR Operation

3.2.2.3 Wake-Up Frame Filter Register (CSR1-PM–Offset 08H)

This register is used for loading the wake-up frame filter register.¹

In order to load the wake-up frame filter register, CSR0<26> must be set and CSR1-PM must be written eight times.

The wake-up frame filter register is undefined after reset, except for the filter command that gets the value of 0. Figure 3–24 shows the CSR1-PM register bit field and Table 3–48 describes the bit field.

Figure 3–24 CSR1-PM Register Bit Field

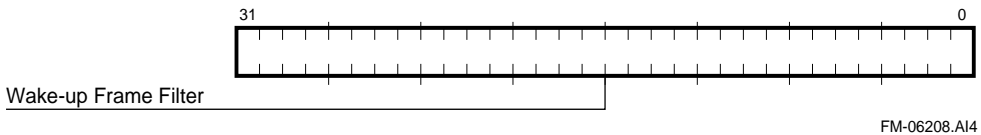

Table 3–48 CSR1-PM Register Bit Field Description

Field	Description
31:0	Wake-Up Frame Filter The first value written to this register, after CSR0<26> was set, is loaded by the 21143 to the first longword in the wake-up frame filter register (filter_0_byte_mask). The second value written to this register is loaded to the second longword in the wake-up frame filter register and so on.

Table 3–49 lists the access rules for the CSR1-PM register.

Table 3–49 CSR1-PM Register Access Rules

Category	Description
Value after reset	Undefined
Read access rules	This is a write-only register.
Write access rules	This register can be written only when the CSR0<26> bit is set.

¹This register only exists on the 21143–PD and the 21143–TD.

3.2.2.4 Wake-Up Frame Filter Register

Figure 3–25 shows the wake-up frame filter register.¹

Figure 3–25 Wake-Up Frame Filter Register Structure

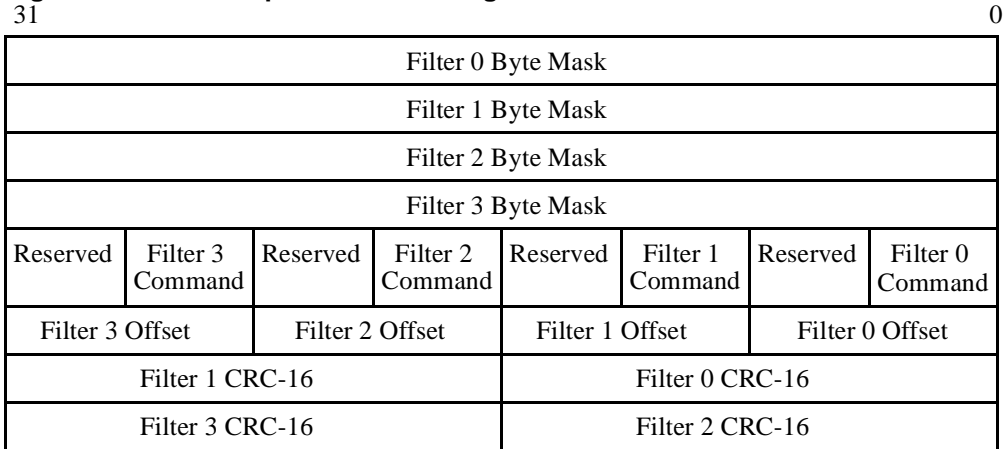

3.2.2.4.1 Filter i Byte Mask

This register defines which bytes of the incoming frames are examined by filter i in order to determine whether or not this is a wake-up frame. Figure 3–26 shows the filter i byte mask register and Table 3–50 describes the bit fields.

Figure 3–26 Filter i Byte Mask Bit Fields

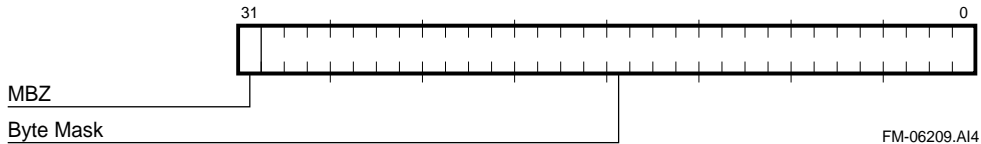

FM-06209.AI4

¹The registers of the wake-up frame filter register do not exist on the 21143–PB, 21143–TB, 21143–PC, and the 21143–TC.

CSR Operation

Table 3–50 Filter i Byte Mask Descriptions

Field	Description
31	MBZ This bit must be zero.
30:0	Byte Mask If bit number j of the byte mask is set, byte number $pattern-offset + j$ of the incoming frame is processed by the CRC machine. Otherwise, byte $pattern-offset + j$ is ignored. This field is not affected by either power-up, hardware, or software reset.

Table 3–51 lists the access rules for the filter i byte mask register.

Table 3–51 Filter i Byte Mask Register Access Rules

Category	Description
Value after reset	Undefined
Read access rules	This is a write-only register.
Write access rules	—

3.2.2.4.2 Filter i Command

This register controls the filter i operation. Figure 3–27 shows the filter i command register.

Figure 3–27 Filter i Command Bit Fields

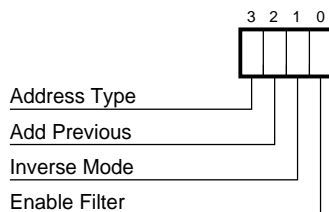

FM-06210.AI4

Table 3–52 describes the filter i command bit fields.

Table 3–52 Filter i Command Descriptions

Field	Description
3	Address Type Defines the destination address type of the pattern. When this bit is set, the pattern applies only to multicast frames. When this bit is cleared, the pattern applies only to unicast frames.
2	Add Previous When this bit is set, the 21143 performs a logical AND between the current filter matching signal and the matching signal of the previous filter. For the first filter, the 21143 chains the filter’s matching signal with the result of the global unicast filter (CRS2-PM<9>).
1	Inverse Mode When this bit is set, the 21143 uses its match signal as a rejection signal. A frame that does not match this filter causes the 21143 to generate a power-management event.
0	Enable Filter When this bit is set, filter i is enabled, otherwise, filter i is disabled.

Table 3–53 lists the access rules for the filter i command register.

Table 3–53 Filter i Command Register Access Rules

Category	Description
Value after reset	00000000
Read access rules	This is a write-only register.
Write access rules	—

CSR Operation

3.2.2.4.3 Filter i Offset

This register defines the offset in the frame's destination address field from which the frames are examined by filter i. Figure 3–28 shows the filter i offset register and Table 3–54 describes the bit fields.

Figure 3–28 Filter i Offset Bit Fields

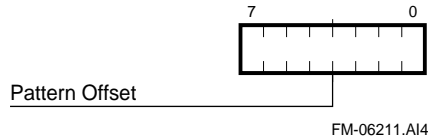

Table 3–54 Filter i Offset Descriptions

Field	Description
7:0	Pattern Offset The offset of the first byte in the frame that is examined by the 21143 in order to check if an incoming frame is a wake-up frame. Offset 0 is the first byte of the incoming frame's destination address. The minimum value allowed for this field is 12. This field is not affected by either power-up, hardware, or software reset.

Table 3–55 lists the access rules for the filter i offset register.

Table 3–55 Filter i Offset Register Access Rules

Category	Description
Value after reset	Undefined
Read access rules	This is a write-only register.
Write access rules	—

3.2.2.4.4 Filter i CRC-16

This register contains the CRC-16 result of a frame that should pass filter i. Figure 3–29 shows the filter i CRC-16 register and Table 3–56 describes the bit fields.

Figure 3–29 Filter i CRC-16 Bit Fields

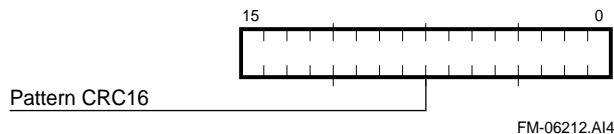

Table 3–56 Filter i CRC-16 Descriptions

Field	Description
15:0	Pattern CRC16 This field contains the 16-bit CRC value calculated from the pattern and the byte mask programmed to the wake-up filter register block. The 21143 compares the result of its CRC machine to this value in order to determine whether the frame is a wake-up frame. This field is not affected by either power-up, hardware, or software reset.

Table 3–57 lists the access rules for the filter i CRC-16 register.

Table 3–57 Filter i CRC-16 Register Access Rules

Category	Description
Value after reset	Undefined
Read access rules	This is a write-only register.
Write access rules	—

CSR Operation

3.2.2.5 Receive Poll Demand Register (CSR2–Offset 10H)

CSR2 is used by the driver to instruct the 21143 to poll the receive descriptor list. Figure 3–30 shows the CSR2 bit field and Table 3–58 describes the bit field.

Figure 3–30 CSR2 Register Bit Field

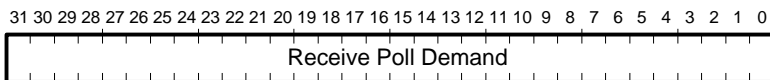

LJ-04705.WMF

Table 3–58 CSR2 Register Bit Field Description

Field	Description
31:0	RPD–Receive Poll Demand (Write Only) When written with any value, the 21143 checks for receive descriptors to be acquired. If no descriptor is available, the receive process returns to the suspended state and CSR5<7> is set. If the descriptor is available, the receive process resumes.

Table 3–59 lists the access rules for the CSR2 register.

Table 3–59 CSR2 Register Access Rules

Category	Description
Value after reset	FFFFFFFFH
Read access rules	—
Write access rules	This register can be written only when the CSR0<26> bit is cleared.

3.2.2.6 Wake-Up Events Control and Status (CSR2-PM–Offset 10H)

This register is used for programming the requested wake-up events and the VLAN parameters, and monitoring the wake-up events.¹

In order to program the requested wake-up events and the VLAN parameters, CSR0<26> must be set. Figure 3–31 shows the CSR2-PM register bit field and Table 3–60 describes the bit field.

Figure 3–31 CSR2-PM Register Bit Field

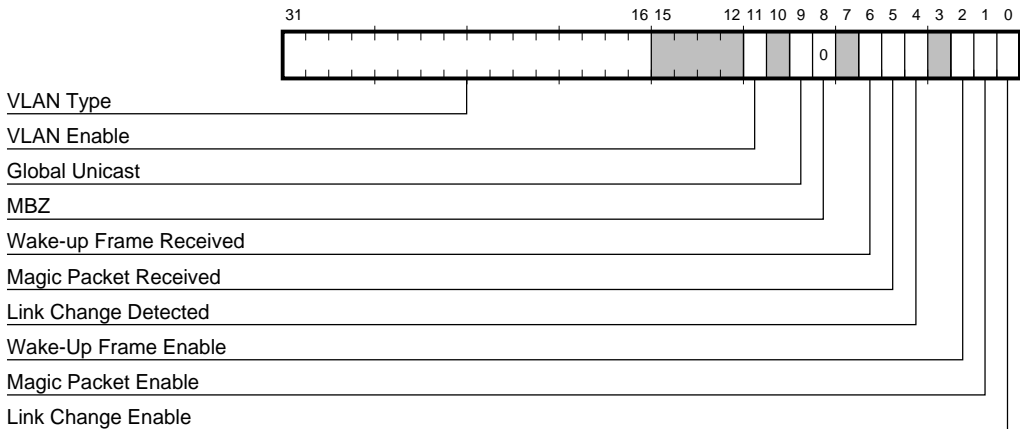

LJ-04705.A14

Table 3–60 CSR2-PM Register Bit Field Description

(Sheet 1 of 2)

Field	Description
31:16	VLAN Type If VLAN Enable bit is set (CSR2-PM<11>), this field should be written with the VLAN type defined by the IEEE 802.1 standard.
11	VLAN Enable When set, enables the 21143's VLAN support as described in Section 7.2.3. This field is reset upon hardware and software reset.
9	Global Unicast When set, enables any unicast packet filtered by the 21143 address recognition to be a wake-up frame.

¹This register only exists on the 21143–PD and the 21143–TD.

CSR Operation

Table 3–60 CSR2-PM Register Bit Field Description

(Sheet 2 of 2)

Field	Description
8	MBZ This bit must be zero.
6	Wake-Up Frame Received If set, indicates that a power-management event was generated due to reception of a wake-up frame. This bit is cleared by write 1, or upon power-up reset. It is unaffected by either hardware or software reset.
5	Magic Packet Received If set, indicates that a power-management event was generated due to reception of a Magic Packet. This bit is cleared by write 1, or upon power-up reset. It is unaffected by either hardware or software reset.
4	Link Change Detected If set, indicates that a power-management event was generated due to link change. This bit is cleared by write 1, or upon power-up reset. It is unaffected by either hardware or software reset.
2	Wake-Up Frame Enable If set, enables generation of a power-management event due to reception of a wake-up frame.
1	Magic Packet Enable If set, enables generation of a power-management event due to Magic Packet reception
0	Link Change Enable If set, enables generation of a power-management event due to link change.

Table 3–61 lists the access rules for the CSR2-PM register.

Table 3–61 CSR2-PM Register Access Rules

Category	Description
Value after reset	Undefined
Read access rules	—
Write access rules	This register can be written only when the CSR0<26> bit is set.

3.2.2.7 Descriptor List Base Address Registers (CSR3–Offset 18H and CSR4–Offset 20H)

The CSR3 descriptor list base address register is used for receive buffer descriptors, and the CSR4 descriptor list base address register is used for transmit buffer descriptors. In both cases, the registers are used to point the 21143 to the start of the appropriate descriptor list.

Note: The descriptor lists reside in *physical* memory space and must be *long-word* aligned. The 21143 behavior is **UNPREDICTABLE** when the lists are not longword aligned.

Figure 3–32 shows the CSR3 register bit field and Table 3–62 describes the bit field.

Writing to either CSR3 or CSR4 is permitted only when its respective process is in the stopped state. When stopped, the CSR3 and CSR4 registers must be written *before* the respective START command is given (Section 3.2.2.9).

Figure 3–32 CSR3 Register Bit Field

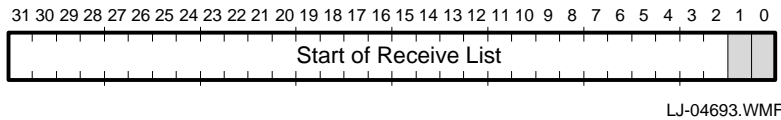

Table 3–62 CSR3 Register Bit Fields Description

Field	Description
31:2	Start of Receive List This field contains the base address of the first descriptor in the receive descriptor list.
1:0	Must be 00 for longword alignment.

Table 3–63 lists the access rules for the CSR3 register.

CSR Operation

Table 3–63 CSR3 Register Access Rules

Category	Description
Value after reset	Undefined
Read access rules	—
Write access rules	Writing to this register is allowed only when the receive process is stopped.

Figure 3–33 shows the CSR4 register bit field and Table 3–64 describes the bit field.

Figure 3–33 CSR4 Register Bit Field

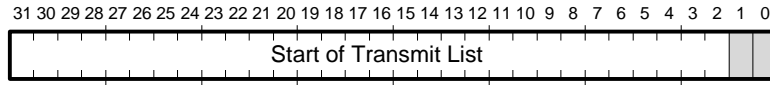

LJ-04694.WMF

Table 3–64 CSR4 Register Bit Fields Description

Field	Description
31:2	Start of Transmit List This field contains the base address of the first descriptor in the transmit descriptor list.
1:0	Must be 00 for longword alignment.

Table 3–65 lists the access rules for the CSR4 register.

Table 3–65 CSR4 Register Access Rules

Category	Description
Value after reset	Undefined
Read access rules	—
Write access rules	Writing to this register is allowed only when the receive process is stopped.

3.2.2.8 Status Register (CSR5–Offset 28H)

The status register (CSR5) contains all the status bits that the 21143 reports to the host. CSR5 is usually read by the driver during interrupt service routine or polling. Most of the fields in this register cause the host to be interrupted. CSR5 bits are not cleared when read. Writing 1 to these bits clears them; writing 0 has no effect. Each field can be masked (Section 3.2.2.10).

CSR Operation

Figure 3–34 shows the CSR5 register bit fields.

Figure 3–34 CSR5 Register Bit Fields

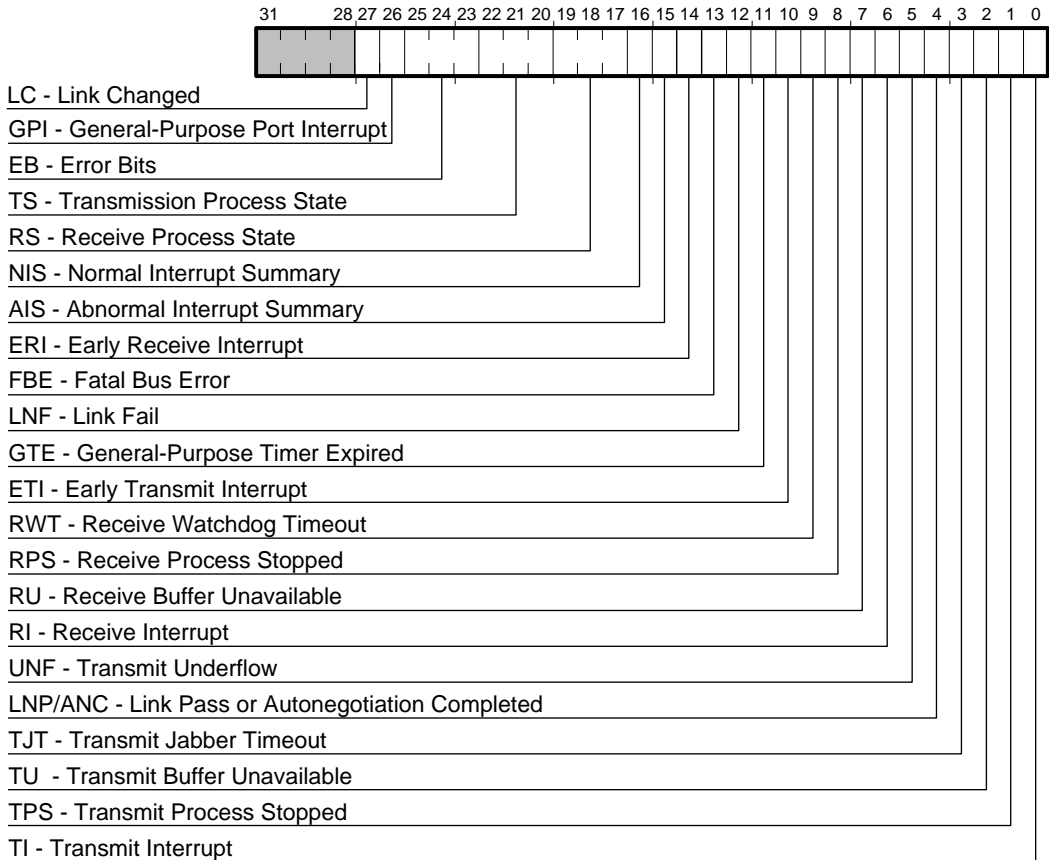

LJ-05118.AI4

Table 3–66 describes the CSR5 register bit fields.

Table 3–66 CSR5 Register Bit Fields Description

(Sheet 1 of 5)

Field	Description
27	<p>LC—Link Changed</p> <p>Indicates that the 100BASE-T link status has changed from link pass to link fail or from link fail to link pass. The new status can be read from CSR12<1>, 100BASE-T link status.</p>

Table 3–66 CSR5 Register Bit Fields Description

(Sheet 2 of 5)

Field	Description
26	<p>GPI—General-Purpose Port Interrupt</p> <p>Indicates an interrupt from the general-purpose port. The value of this bit is the logical <i>OR</i> of:</p> <ul style="list-style-type: none"> CSR15<30>—Receive match interrupt CSR15<29>—General-purpose port interrupt 1 CSR15<28>—General-purpose port interrupt 0 <p>Only unmasked bits affect the value of the general-purpose port CSR5<26> bit.</p>
25:23	<p>EB—Error Bits (Read Only)</p> <p>Indicates the type of error that caused bus error. Valid only when fatal bus error CSR5<13> is set (Table 3–67).</p> <p>This field does not generate an interrupt.</p>
22:20	<p>TS—Transmission Process State (Read Only)</p> <p>Indicates the state of the transmit process (Table 3–68). This field does not generate an interrupt.</p>
19:17	<p>RS—Receive Process State (Read Only)</p> <p>Indicates the state of the receive process (Table 3–69). This field does not generate an interrupt.</p>
16	<p>NIS—Normal Interrupt Summary</p> <p>Normal interrupt summary bit. Its value is the logical <i>OR</i> of:</p> <ul style="list-style-type: none"> CSR5<0>—Transmit interrupt CSR5<2>—Transmit buffer unavailable CSR5<6>—Receive interrupt CSR5<11>—General-purpose timer and interrupt mitigation control CSR5<14>—Early receive interrupt <p>Only unmasked bits affect the normal interrupt summary CSR5<16> bit.</p>

CSR Operation

Table 3–66 CSR5 Register Bit Fields Description

(Sheet 3 of 5)

Field	Description
15	AIS—Abnormal Interrupt Summary Abnormal interrupt summary bits. Its value is the logical <i>OR</i> of: CSR5<1>—Transmit process stopped CSR5<3>—Transmit jabber timeout CSR5<4>—Link pass or autonegotiation completed CSR5<5>—Transmit underflow CSR5<7>—Receive buffer unavailable CSR5<8>—Receive process stopped CSR5<9>—Receive watchdog timeout CSR5<10>—Early transmit interrupt CSR5<12>—Link fail CSR5<13>—Fatal bus error CSR5<26>—General-purpose port interrupt CSR5<27>—Link changed Only unmasked bits affect the abnormal interrupt summary CSR5<15> bit. The transmit interrupt (CSR5<0>) automatically clears the early transmit interrupt (CSR5<10>). To keep the int_1 pin asserted when there are early transmit interrupts with the transmit interrupt masked, the abnormal interrupt summary bit should remain set after the early transmit interrupt is cleared. To clear the abnormal interrupt summary bit in this case, the early transmit interrupt bit should be written with a value of 1.
14	ERI—Early Receive Interrupt Indicates that the 21143 has filled the first data buffer of the packet. Receive interrupt (CSR5<6>) automatically clears this bit.
13	FBE—Fatal Bus Error Indicates that a bus error occurred (Table 3–67). When this bit is set, the 21143 disables all of its bus access operations.
12	LNF—Link Fail Indicates a transition to the link fail state in the twisted-pair port. See link fail status CSR12<2>. This bit is valid only when CSR6<18>, Port Select, is reset; CSR14<8>, Receive Squelch Enable, is set; and CSR13<3>, 10BASE-T or AUI, is 0 (10BASE-T mode). Link pass CSR5<4> automatically clears this bit.
11	GTE—General-Purpose Timer and Interrupt Mitigation Control Expired Indicates that the general-purpose timer and interrupt mitigation control (CSR11) counter has expired. This timer is mainly used by the software driver.

Table 3–66 CSR5 Register Bit Fields Description

(Sheet 4 of 5)

Field	Description
10	<p>ETI—Early Transmit Interrupt</p> <p>Indicates that the packet to be transmitted was fully transferred into the chip’s internal transmit FIFOs. Transmit interrupt (CSR5<0>) automatically clears this bit, but the abnormal interrupt summary bit remains set if ETI was enabled.</p>
9	<p>RWT—Receive Watchdog Timeout</p> <p>This bit reflects the line status and indicates that the receive watchdog timer has expired while another node is still active on the network. In case of overflow, the long packets may not be received.</p>
8	<p>RPS—Receive Process Stopped</p> <p>Asserts when the receive process enters the stopped state.</p>
7	<p>RU—Receive Buffer Unavailable</p> <p>Indicates that the next descriptor in the receive list is owned by the host and cannot be acquired by the 21143. The reception process is suspended. To resume processing receive descriptors, the host should change the ownership of the descriptor and issue a receive poll demand command. If no receive poll demand is issued, the reception process resumes when the next recognized incoming frame is received. CSR5<7> is set only when the previous receive descriptor was owned by the 21143.</p>
6	<p>RI—Receive Interrupt</p> <p>Indicates the completion of a frame reception. Specific frame status information has been posted in the descriptor. The reception process remains in the running state.</p>
5	<p>UNF—Transmit Underflow</p> <p>Indicates that the transmit FIFO had an underflow condition during the packet transmission. The transmit process is placed in the suspended state and underflow error TDES0<1> is set.</p>
4	<p>LNP/ANC—Link Pass or Autonegotiation Completed</p> <p>When autonegotiation is not enabled (CSR14<7>=0), this bit indicates that the 10BASE-T Link Integrity Test has completed successfully, after the link was down. This bit is also set as a result of writing 0 to CSR14<12>, Link Test Enable.</p> <p>When autonegotiation is enabled (CSR14<7>=1), this bit indicates that the autonegotiation has completed (CSR12<14:12>=5H). CSR12 should then be read for a link status report. This bit is valid only when port select (CSR6<18>) is reset, and receive squelch enable (CSR14<8>) is set.</p> <p>Link fail interrupt (CSR5<12>) automatically clears this bit.</p>
3	<p>TJT—Transmit Jabber Timeout</p> <p>Indicates that the transmit jabber timer expired, meaning that the 21143 transmitter had been excessively active. The transmission process is <i>aborted</i> and placed in the stopped state. This event causes the transmit jabber timeout TDES0<14> flag to be set.</p>

CSR Operation

Table 3–66 CSR5 Register Bit Fields Description

(Sheet 5 of 5)

Field	Description
2	TU—Transmit Buffer Unavailable Indicates that the next descriptor on the transmit list is owned by the host and cannot be acquired by the 21143. The transmission process is suspended. Table 4–14 explains the transmit process state transitions. To resume processing transmit descriptors, the host should change the ownership bit of the descriptor and then issue a transmit poll demand command, unless transmit automatic polling (Table 3–43) is enabled.
1	TPS—Transmit Process Stopped Sets when the transmit process enters the stopped state.
0	TI—Transmit Interrupt Indicates that a frame transmission was completed and TDES1<31> is set in the first descriptor of the frame.

Table 3–67 lists the bit codes for the fatal bus error bits.

Table 3–67 Fatal Bus Error Bits

CSR5<25:23>	Error Type
000	Parity error ¹
001	Master abort
010	Target abort
011	Reserved
1xx	Reserved

¹The only way to recover from a parity error is by issuing a software reset (CSR0<0>=1).

Table 3–68 lists the bit codes for the transmit process state.

Table 3–68 Transmit Process State

CSR5<22:20>	Process State
000	Stopped—RESET command or STOP COMMAND issued, or transmit jabber expired
001	Running—Fetching transmit descriptor
010	Running—Waiting for end of transmission
011	Running—Reading buffer from memory and queuing the data into the transmit FIFO
100	Reserved
101	Running—Setup packet
110	Suspended—Transmit FIFO underflow, or an unavailable transmit descriptor
111	Running—Closing transmit descriptor

CSR Operation

Table 3–69 lists the bit codes for the receive process state.

Table 3–69 Receive Process State

CSR5<19:17>	Process State
000	Stopped—RESET or STOP RECEIVE command issued
001	Running—Fetching receive descriptor
010	Running—Checking for end of receive packet before prefetch of next descriptor
011	Running—Waiting for receive packet
100	Suspended—Unavailable receive buffer
101	Running—Closing receive descriptor
110	Running—Flushing the current frame from the receive FIFO because of unavailable receive buffer
111	Running—Queuing the receive frame from the receive FIFO into the receive buffer

Table 3–70 lists the access rules for the CSR5 register.

Table 3–70 CSR5 Register Access Rules

Category	Description
Value after reset	F0000000H
Read access rules	—
Write access rules	CSR5 bits 0 through 16, bit 26, and bit 27 are cleared by writing 1. Writing 0 to these bits has no effect. CSR5 bits 17 through 25 are read-only bits.

3.2.2.9 Operation Mode Register (CSR6—Offset 30H)

The operation mode register (CSR6) establishes the receive and transmit operating modes and commands. CSR6 should be the last CSR to be written as part of initialization. Figure 3–35 shows the CSR6 register bit fields.

Figure 3–35 CSR6 Register Bit Fields

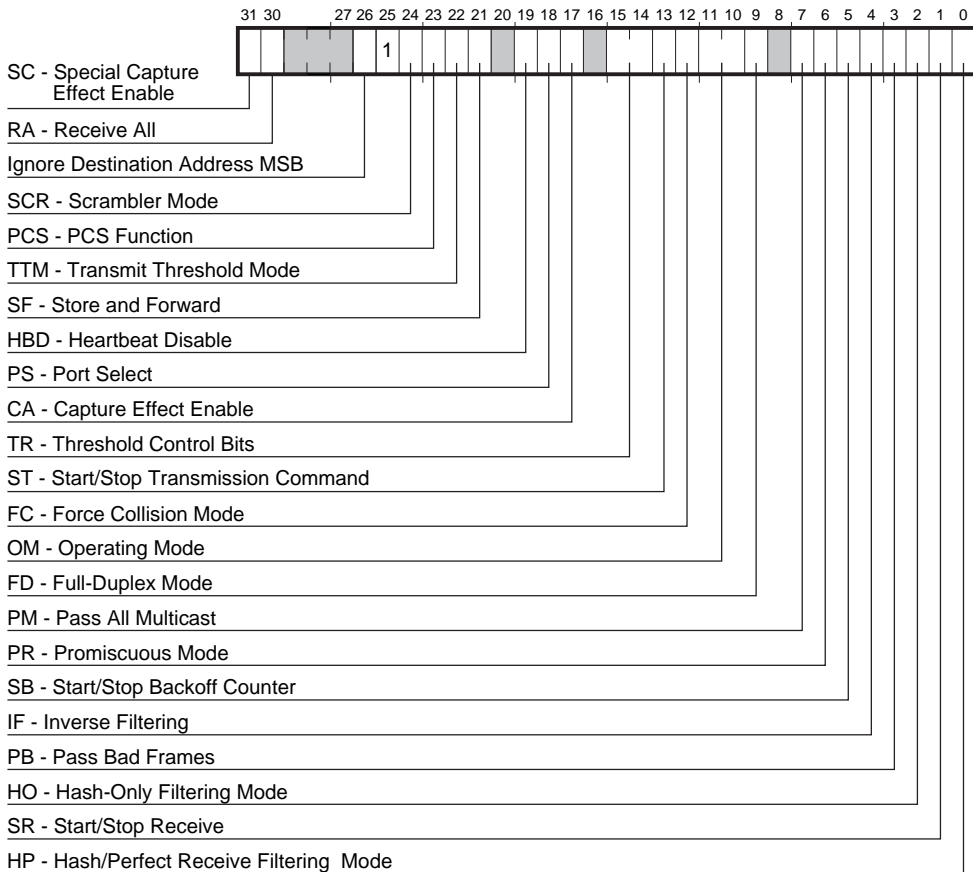

LJ-05022.AI4

Table 3–71 describes the CSR6 register bit fields.

Table 3–71 CSR6 Register Bit Fields Description

(Sheet 1 of 5)

Field	Description
31	<p>SC—Special Capture Effect Enable</p> <p>When set, enables the enhanced resolution of capture effect on the network (Section 6.7.3). DIGITAL recommends that this bit be set when CSR6<17> is set. When clear, the 21143 disables the enhanced resolution of capture effect on the network.</p>

CSR Operation

Table 3–71 CSR6 Register Bit Fields Description

(Sheet 2 of 5)

Field	Description
30	RA—Receive All When set, all incoming packets are received, regardless of the destination address. The address match is checked according to Table 3–75, and is reported in RDES0<30>.
26	Ignore Destination Address MSB¹ When set, bit 47 of the destination address is ignored in the MAC's address filtering. This bit is meaningful only if the 21143 is programmed to do perfect address filtering. It is cleared upon hardware and software reset.
25	MBO—Must Be One This bit should always be programmed to one.
24	SCR—Scrambler Mode When set, the scrambler function is active and the MII/SYM port transmits and receives scrambled signals. This bit must be cleared when CSR6<23> bit is cleared. Changing this bit during operation may cause UNPREDICTABLE behavior.
23	PCS—PCS Function When set, the PCS functions are active and the MII/SYM port operates in symbol mode. The mii_rx_err/sel10_100 pin functions as the select 10/100 output pin. When reset, the PCS functions are not active, and the MII/SYM port operates in MII mode. The mii_rx_err/sel10_100 pin functions as the mii_rx_err input pin. Changing this bit during operation may cause UNPREDICTABLE behavior.
22	TTM—Transmit Threshold Mode Selects the transmit FIFO threshold to be either 10 Mb/s or 100 Mb/s (Table 3–72). When set, the threshold is 10 Mb/s. When reset, the threshold is 100 Mb/s. This bit can be changed only when the transmit process is in the stopped state.
21	SF—Store and Forward When set, transmission starts when a full packet resides in the FIFO. When this occurs, the threshold values specified in CSR6<15:14> are ignored. This bit can be changed only when the transmit process is in the stopped state.
19	HBD—Heartbeat Disable When set, the heartbeat signal quality (SQE) generator function is disabled. This bit should be set in the MII/SYM 100-Mb/s mode. In the MII 10-Mb/s mode this bit should be set according to the PHY device configuration.

Table 3–71 CSR6 Register Bit Fields Description

(Sheet 3 of 5)

Field	Description
18	<p>PS—Port Select</p> <p>When reset, the 10BASE-T or AUI port is selected according to the CSR13<3> value. When set, the MII/SYM port is selected (Table 3–73). During a hardware reset, this bit automatically resets. A software reset does not affect this bit.</p>
17	<p>CA—Capture Effect Enable</p> <p>When set, enables the 21143 feature that solves the capture effect problem on the network (Section 6.7). When reset, this 21143 feature is disabled.</p>
15:14	<p>TR—Threshold Control Bits</p> <p>Controls the selected threshold level for the 21143 transmit FIFO. The threshold value has a direct impact on the 21143 bus arbitration scheme (Section 4.3.2). Transmission starts when the frame size within the transmit FIFO is larger than the threshold. In addition, full frames with a length less than the threshold are also transmitted. This bit can be changed only when the transmit process is in the stopped state.</p>
13	<p>ST—Start/Stop Transmission Command</p> <p>When set, the transmission process is placed in the running state, and the 21143 checks the transmit list at the <i>current</i> position for a frame to be transmitted. Descriptor acquisition is attempted either from the <i>current</i> position in the list, which is the transmit list base address set by CSR4, or from the position retained when the transmit process was previously stopped. If the current descriptor is not owned by the 21143, the transmission process enters the suspended state and transmit buffer unavailable (CSR5<2>) is set. The start transmission command is effective only when the transmission process is stopped. If the command is issued before setting CSR4, the 21143 behavior will be UNPREDICTABLE. When reset, the transmission process is placed in the stopped state after completing the transmission of the current frame. The next descriptor position in the transmit list is saved, and becomes the current position when transmission is restarted. The stop transmission command is effective only when the transmission process is in either the running or suspended state (Table 4–14).</p>
12	<p>FC—Force Collision Mode</p> <p>Allows the collision logic to be tested. Meaningful only in internal loopback mode. When set, a collision is forced during the next transmission attempt. This results in 16 transmission attempts with excessive collision reported in the transmit descriptor (TDES0<8>).</p>
11:10	<p>OM—Operating Mode</p> <p>Selects the 21143 loopback operation modes (Table 3–74).</p>

CSR Operation

Table 3–71 CSR6 Register Bit Fields Description

(Sheet 4 of 5)

Field	Description
9	FD—Full-Duplex Mode When autonegotiation is disabled (CSR14<7> = 0), this bit selects the 21143 half-duplex or full-duplex operation mode. A 0 selects half-duplex operation while a 1 selects full-duplex operation. When autonegotiation is enabled (CSR14<7> = 1) and the 21143 is operating in 10BASE-T mode (CSR6<18> = 0 and CSR13<3> = 0), this bit controls the advertisement of 10BASE-T full-duplex capability (bit 6) in the transmitted code word. The 21143 will operate in 10BASE-T full-duplex mode <i>only</i> if both link partners are advertising this bit set. This bit has no meaning in AUI mode (CSR6<18> = 0 and CSR13<3> = 1). Changing the full-duplex bit is permitted only if the transmit and receive processes are in the stopped state. While in full-duplex mode, heartbeat check is disabled, heartbeat fail (TDES0<7>) should be ignored, and internal loopback is not allowed.
7	PM—Pass All Multicast When set, indicates that all the incoming frames with a multicast destination address (first bit in the destination address field is 1) are received. Incoming frames with physical address destinations are filtered according to the CSR6<0> bit.
6	PR—Promiscuous Mode When set, indicates that any incoming valid frame is received, regardless of its destination address.
5	SB—Start/Stop Backoff Counter When set, indicates that the internal backoff counter stops counting when any carrier activity is detected. The 21143 backoff counter resumes when the carrier drops. The earliest the 21143 starts its transmission after carrier deassertion is 9.6 μ s for 10-Mb/s data rate or 0.96 μ s for 100-Mb/s data rate. When reset, the internal backoff counter is not affected by the carrier activity.
4	IF—Inverse Filtering (Read Only) When set, the 21143 operates in an inverse filtering mode. This is valid only during perfect filtering mode (Table 3–75 and Table 4–8).
3	PB—Pass Bad Frames When set, the 21143 operates in pass bad frame mode. All incoming frames that passed the address filtering are received, including runt frames, collided fragments, or truncated frames caused by FIFO overflow. If any received bad frames are required, promiscuous mode (CSR6<6>) should be set to 1.
2	HO—Hash-Only Filtering Mode (Read Only) When set, the 21143 operates in an imperfect address filtering mode for both physical and multicast addresses (Table 4–8).

Table 3–71 CSR6 Register Bit Fields Description

(Sheet 5 of 5)

Field	Description
1	<p>SR—Start/Stop Receive</p> <p>When set, the receive process is placed in the running state. The 21143 attempts to acquire a descriptor from the receive list and processes incoming frames. Descriptor acquisition is attempted from the <i>current</i> position in the list, which is the address set by <i>CSR3</i> or the position retained when the receive process was previously stopped. If no descriptor is owned by the 21143, the receive process enters the suspended state and receive buffer unavailable (<i>CSR5</i><7>) sets.</p> <p>The start reception command is effective only when the reception process has stopped. If the command was issued before setting <i>CSR3</i>, the 21143 behavior is UNPREDICTABLE.</p> <p>When cleared, the receive process enters the stopped state after completing the reception of the current frame. The next descriptor position in the receive list is saved, and becomes the <i>current</i> position after the receive process is restarted. The stop reception command is effective only when the receive process is in running or suspended state (Table 4–13).</p>
0	<p>HP—Hash/Perfect Receive Filtering Mode (Read Only)</p> <p>When reset, the 21143 does a perfect address filter of incoming frames according to the addresses specified in the setup frame (Table 4–8).</p> <p>When set, the 21143 does imperfect address filtering of multicast incoming frames according to the hash table specified in the setup frame. If <i>CSR6</i><2> is set, then physical addresses are imperfect address filtered too. If <i>CSR6</i><2> is reset, physical addresses are perfect address filtered, according to a single physical address, as specified in the setup frame.</p>

[†]This feature is only supported in the 21143–PD and the 21143–TD.

CSR Operation

Table 3–72 lists the threshold values in bytes.

Table 3–72 Transmit Threshold

CSR6<21>	CSR6<15:14>	CSR6<18> = 0 CSR6<22> = X	CSR6<18> = 1 CSR6<22> = 1	CSR6<18> = 1 CSR6<22> = 0
0	00	72	72	128
0	01	96	96	256
0	10	128	128	512
0	11	160	160	1024
1	XX	Store and forward	Store and forward	Store and forward

Table 3–73 lists the port and data rate selection.

Table 3–73 Port and Data Rate Selection

CSR6 <18>	CSR6 <22>	CSR6 <23>	CSR6 <24>	Active Port	Data Rate	Function
0	0	X	X	10BASE-T/ AUI	10 Mb/s	10BASE-T or AUI interface
1	1	0	0	MII/SYM	10 Mb/s	MII with transmit FIFO thresholds appropriate for 10 Mb/s
1	0	0	0	MII/SYM	100 Mb/s	MII with transmit FIFO thresholds appropriate for 100 Mb/s
1	0	1	0	MII/SYM	100 Mb/s	PCS function for 100BASE-FX
1	0	1	1	MII/SYM	100 Mb/s	PCS and scrambler functions for 100BASE-TX

Table 3–74 selects the 21143 loopback operation modes.

Table 3–74 Loopback Operation Mode

CSR6<11:10>	Operation Mode
00	Normal
01	Internal loopback ¹
10	External loopback

¹The selected port is placed in the internal loopback mode of operation. The PCS function (CSR6<23>) and the scrambler mode (CSR6<24>) are also tested. When the SYM port is in internal loopback mode, symbols appear on the network. When the MII port is in internal loopback mode, the signal **mii_txen** is disabled.

Table 3–75 lists the codes to determine the filtering mode.

Table 3–75 Filtering Mode

CSR6<7>	CSR6<6>	CSR6<4>	CSR6<2>	CSR6<0>	Filtering Mode
0	0	0	0	0	16 perfect filtering
0	0	0	0	1	512-bit hash + 1 perfect filtering
0	0	0	1	1	512-bit hash for multicast and physical addresses
0	0	1	0	0	Inverse filtering
X	1	0	0	X	Promiscuous
0	1	0	1	1	Promiscuous
1	0	0	0	X	Pass all multicast
1	0	0	1	1	Pass all multicast

Note: When CSR6<30> is set (receive all mode), this table is used to generate the address match status reported in RDES0<30>.

CSR Operation

Table 3–76 describes the only conditions that permit change to a field when modifying values to the CSR6 register.

Table 3–76 CSR6 Register Access Rules

Category	Description
Value after reset	32000040H
Read access rules	—
Write access rules	
* CSR6<22>	Receive and transmit processes stopped
* CSR6<21>	Receive and transmit processes stopped
* CSR6<17>	Receive and transmit processes stopped
* CSR6<16>	Receive and transmit processes stopped
* CSR6<15:14>	Transmit process stopped
* CSR6<12>	Receive and transmit processes stopped
* CSR6<11:10>	Receive and transmit processes stopped
* CSR6<9>	Receive and transmit processes stopped
* CSR6<8>	Transmit process stopped
* CSR6<5>	Receive and transmit processes stopped
* CSR6<3>	Receive process stopped
* Start_Transmit CSR6<13>=1	CSR4 initialized
* Stop_Transmit CSR6<13>=0	Transmit running or suspended
* Start_Receive CSR6<1>=1	CSR3 initialized
* Stop_Receive CSR6<1>=0	Receive running or suspended

3.2.2.10 Interrupt Enable Register (CSR7–Offset 38H)

The interrupt enable register (CSR7) enables the interrupts reported by CSR5 (Section 3.2.2.8). Setting a bit to 1 enables a corresponding interrupt. After a hardware or software reset, all interrupts are disabled. Figure 3–36 shows the CSR7 register bit fields.

Figure 3–36 CSR7 Register Bit Fields

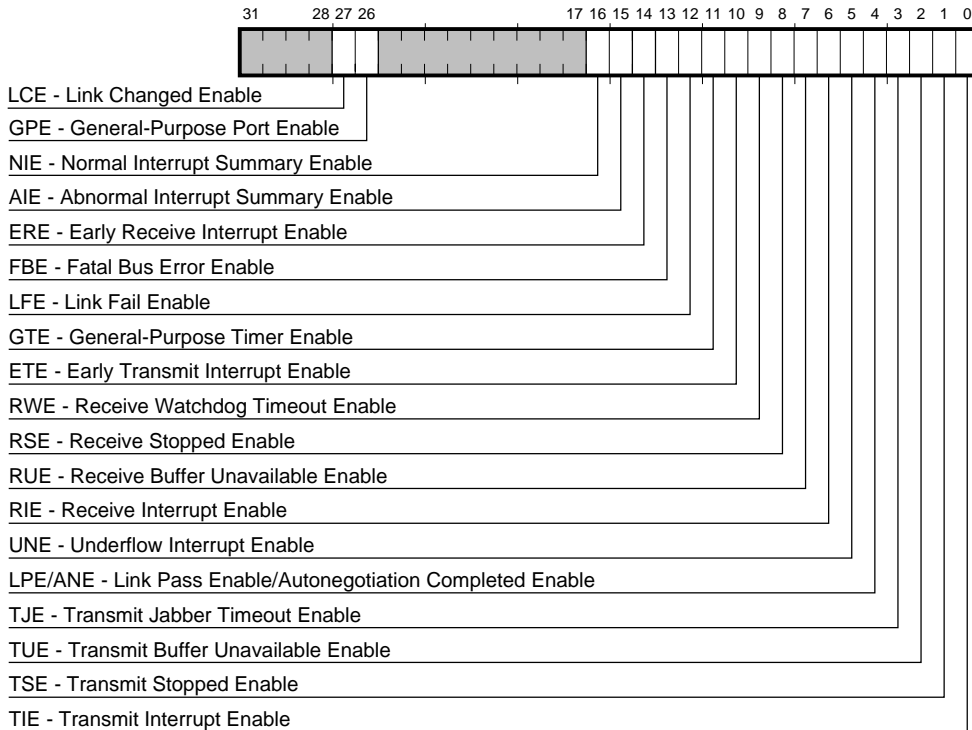

LJ-05119.AI4

CSR Operation

Table 3–77 describes the CSR7 register bit fields.

Table 3–77 CSR7 Register Bit Fields Description

(Sheet 1 of 3)

Field	Description
27	LCE—Link Changed Enable When this bit and the abnormal interrupt summary enable bit (CSR7<15>) are set, the link changed interrupt (CSR5<27>) is enabled. When this bit is reset, the link changed interrupt (CSR5<27>) is disabled.
26	GPE—General-Purpose Port Enable When this bit and the abnormal interrupt summary enable bit (CSR7<15>) are set, the general-purpose port interrupt (CSR5<26>) is enabled. When this bit is reset, the general-purpose port interrupt (CSR5<26>) is disabled.
16	NIE—Normal Interrupt Summary Enable When set, normal interrupt is enabled. When reset, no normal interrupt is enabled. This bit (CSR7<16>) enables the following bits: CSR5<0>—Transmit interrupt CSR5<2>—Transmit buffer unavailable CSR5<6>—Receive interrupt CSR5<11>—General-purpose timer expired CSR5<14>—Early receive interrupt
15	AIE—Abnormal Interrupt Summary Enable When set, abnormal interrupt is enabled. When reset, no abnormal interrupt is enabled. This bit (CSR7<15>) enables the following bits: CSR5<1>—Transmit process stopped CSR5<3>—Transmit jabber timeout CSR5<4>—Link pass or autonegotiation completed CSR5<5>—Transmit underflow CSR5<7>—Receive buffer unavailable CSR5<8>—Receive process stopped CSR5<9>—Receive watchdog timeout CSR5<10>—Early transmit interrupt CSR5<12>—Link fail CSR5<26>—General-purpose port interrupt CSR5<27>—Link changed
14	ERE—Early Receive Interrupt Enable When this bit and the normal interrupt summary enable bit (CSR7<16>) are set, the early receive interrupt (CSR5<14>) is enabled. When this bit is reset, the early receive interrupt (CSR5<14>) is disabled.

Table 3–77 CSR7 Register Bit Fields Description

(Sheet 2 of 3)

Field	Description
13	<p>FBE—Fatal Bus Error Enable</p> <p>When this bit and the abnormal interrupt summary enable bit (CSR7<15>) are set, the fatal bus error interrupt (CSR5<13>) is enabled. When this bit is reset, the fatal bus error interrupt (CSR5<13>) is disabled.</p>
12	<p>LFE—Link Fail Enable</p> <p>When this bit and the abnormal interrupt summary enable bit (CSR7<15>) are set, the link fail interrupt (CSR5<12>) is enabled. When this bit is reset, the link fail interrupt (CSR5<12>) is disabled.</p>
11	<p>GTE—General-Purpose Timer and Interrupt Mitigation Control Enable</p> <p>When this bit and the normal interrupt summary enable bit (CSR7<16>) are set, the general-purpose timer and interrupt mitigation control expired interrupt (CSR5<11>) is enabled. When this bit is reset, the general-purpose timer and interrupt mitigation control expired interrupt (CSR5<11>) is disabled.</p>
10	<p>ETE—Early Transmit Interrupt Enable</p> <p>When this bit and the abnormal interrupt summary enable bit (CSR7<15>) are set, the early transmit interrupt (CSR5<10>) is enabled. When this bit is reset, the early transmit interrupt (CSR5<10>) is disabled.</p>
9	<p>RWE—Receive Watchdog Timeout Enable</p> <p>When this bit and the abnormal interrupt summary enable bit (CSR7<15>) are set, the receive watchdog timeout interrupt (CSR5<9>) is enabled. When this bit is reset, the receive watchdog timeout interrupt (CSR5<9>) is disabled.</p>
8	<p>RSE—Receive Stopped Enable</p> <p>When this bit and the abnormal interrupt summary enable bit (CSR7<15>) are set, the receive stopped interrupt (CSR5<8>) is enabled. When this bit is reset, the receive stopped interrupt (CSR5<8>) is disabled.</p>
7	<p>RUE—Receive Buffer Unavailable Enable</p> <p>When this bit and the abnormal interrupt summary enable bit (CSR7<15>) are set, the receive buffer unavailable interrupt (CSR5<7>) is enabled. When this bit is reset, the receive buffer unavailable interrupt (CSR5<7>) is disabled.</p>
6	<p>RIE—Receive Interrupt Enable</p> <p>When this bit and the normal interrupt summary enable bit (CSR7<16>) are set, the receive interrupt (CSR5<6>) is enabled. When this bit is reset, the receive interrupt (CSR5<6>) is disabled.</p>

CSR Operation

Table 3–77 CSR7 Register Bit Fields Description

(Sheet 3 of 3)

Field	Description
5	UNE—Underflow Interrupt Enable When this bit and the abnormal interrupt summary enable bit (CSR7<15>) are set, the transmit underflow interrupt (CSR5<5>) is enabled. When this bit is reset, the transmit underflow bit (CSR5<5>) is disabled.
4	LPE/ANE—Link Pass Enable/Autonegotiation Completed Enable When this bit and the abnormal interrupt summary enable bit (CSR7<15>) are set, the link pass/autonegotiation completed interrupt (CSR5<4>) is enabled. When this bit is reset, the link pass/autonegotiation completed bit (CSR5<4>) is disabled.
3	TJE—Transmit Jabber Timeout Enable When this bit and the abnormal interrupt summary enable bit (CSR7<15>) are set, the transmit jabber timeout interrupt (CSR5<3>) is enabled. When this bit is reset, the transmit jabber timeout interrupt (CSR5<3>) is disabled.
2	TUE—Transmit Buffer Unavailable Enable When this bit and the normal interrupt summary enable bit (CSR7<16>) are set, the transmit buffer unavailable interrupt (CSR5<2>) is enabled. When this bit is reset, the transmit buffer unavailable interrupt (CSR5<2>) is disabled.
1	TSE—Transmit Stopped Enable When this bit and the abnormal interrupt summary enable bit (CSR7<15>) are set, the transmit process stopped interrupt (CSR5<1>) is enabled. When this bit is reset, the transmit process stopped interrupt (CSR5<1>) is disabled.
0	TIE—Transmit Interrupt Enable When this bit and the normal interrupt summary enable bit (CSR7<16>) are set, the transmit interrupt (CSR5<0>) is enabled. When this bit is reset, the transmit interrupt (CSR5<0>) is disabled.

Table 3–78 lists the access rules for the CSR7 register.

Table 3–78 CSR7 Register Access Rules

Category	Description
Value after reset	F3FE0000H
Read access rules	—
Write access rules	—

3.2.2.11 Missed Frames and Overflow Counter Register (CSR8—Offset 40H)

Figure 3–37 shows the CSR8 bit fields and Table 3–79 describes the bit fields.

Figure 3–37 CSR8 Missed Frames and Overflow Counter

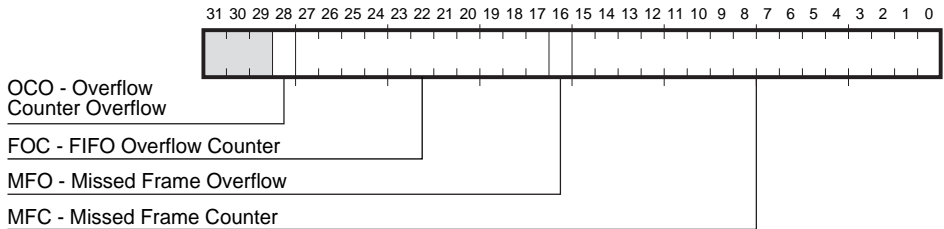

LJ-05024.A14

Table 3–79 CSR8 Register Bit Fields Description

Field	Description
28	OCO—Overflow Counter Overflow (Read Only) Sets when the FIFO overflow counter overflows; resets when CSR8 is read.
27:17	FOC—FIFO Overflow Counter (Read Only) Indicates the number of received frames discarded because of receive FIFO overflow. The counter clears when read. Packets longer than 4KB are not counted.
16	MFO—Missed Frame Overflow (Read Only) Sets when the missed frame counter overflows; resets when CSR8 is read.
15:0	MFC—Missed Frame Counter (Read Only) Indicates the number of frames discarded because no host receive descriptors were available (CSR5<7>, RU – Receive Buffer Unavailable). The counter clears when read.

Table 3–80 lists the access rules for the CSR8 register.

Table 3–80 CSR8 Register Access Rules

Category	Description
Value after reset	E0000000H
Read access rules	—
Write access rules	This is a read-only register.

CSR Operation

3.2.2.12 Boot ROM, Serial ROM, and MII Management Register (CSR9–Offset 48H)

The boot ROM, serial ROM, and MII management register (CSR9) provides an interface to the boot ROM, serial ROM, and MII management. It selects the device and contains both the commands and data to be read from and stored in the boot ROM and serial ROM. The MII management selects an operation mode for reading and writing the MII PHY registers through the MII management interface.

Figure 3–38 shows the CSR9 register bit fields.

Figure 3–38 CSR9 Register Bit Fields

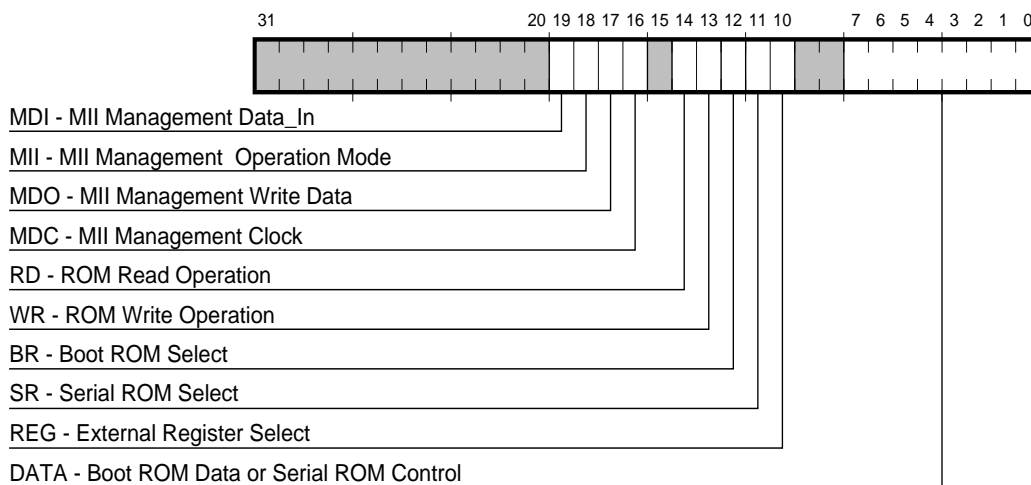

LJ-05203.A14

Table 3–81 describes the CSR9 register bit fields.

Table 3–81 CSR9 Register Bit Fields Description

(Sheet 1 of 2)

Field	Description
19	<p>MDI—MII Management Data_In</p> <p>When reading the MII PHY registers, this bit samples the value driven by the PHY on the mii_mdio pin.</p>
18	<p>MII—MII Management Operation Mode</p> <p>Defines the operation mode (read or write) of the MII PHY registers. When set, the 21143 reads the MII PHY registers. The mii_mdio pin is sampled by the 21143 into the MII management data in (CSR9<19>) bit.</p> <p>When cleared, the 21143 writes to the MII PHY registers. The mii_mdio pin is driven by the 21143 with the MII management write data (CSR9<17>) bit.</p>
17	<p>MDO—MII Management Write Data</p> <p>When writing to the MII PHY device, the 21143 drives the value of this bit on the mii_mdio pin.</p>
16	<p>MDC—MII Management Clock</p> <p>The value of this bit is driven by the 21143 on the mii_mdc pin. This bit should be cleared at the end of each MII register access.</p>
14	<p>RD—ROM Read Operation</p> <p>Read control bit. When set, together with either CSR9<12>, CSR9<11>, or CSR9<10>, the 21143 performs read cycles from the selected target (boot ROM, the serial ROM, or external register).</p> <p>Setting this bit together with CSR9<13> will cause UNPREDICTABLE behavior.</p>
13	<p>WR—ROM Write Operation</p> <p>Write control bit. When set, together with either CSR9<12>, CSR9<11>, or CSR9<10>, the 21143 performs write cycles to the selected target (boot ROM, the serial ROM, or external register).</p> <p>Setting this bit together with CSR9<14> will cause UNPREDICTABLE behavior.</p>
12	<p>BR—Boot ROM Select</p> <p>When set, the 21143 selects the boot ROM. Setting this bit together with CSR9<11> or CSR9<10> will cause UNPREDICTABLE behavior.</p>
11	<p>SR—Serial ROM Select</p> <p>When set, the 21143 selects the serial ROM. Setting this bit together with CSR9<12> or CSR9<10> will cause UNPREDICTABLE behavior.</p>

CSR Operation

Table 3–81 CSR9 Register Bit Fields Description

(Sheet 2 of 2)

Field	Description
10	REG—External Register Select When set, the 21143 selects an external register (Section 8.5). Setting this bit together with CSR9<12> or CSR9<11> will cause UNPREDICTABLE behavior.
7:0	DATA—Boot ROM Data or Serial ROM Control If the boot ROM is selected, this field contains the data to be read from and written to the boot ROM. If the serial ROM is selected, CSR9<3:0> bits are connected to the serial ROM control pins as follows: Bit 3, Data Out —This bit samples the value driven by the serial ROM on the sr_do pin. Bit 2, Data In —The value of this bit is driven by the 21143 on the sr_di pin. Bit 1, Serial ROM Clock —The value of this bit is driven by the 21143 on the sr_ck pin. Bit 0, Serial ROM Chip Select —The value of this bit is driven by the 21143 on the sr_cs pin. If the external register is selected, this field contains the data to be read from and written to the external register. If CSR9<12> bit is set, this field is not affected by a software reset.

Table 3–82 lists the access rules for the CSR9 register.

Table 3–82 CSR9 Register Access Rules

Category	Description
Value after reset	FFF483FFH ¹
Read access rules	—
Write access rules	CSR9<14> and CSR9<13> must not be set together. CSR9<12>, CSR9<11>, and CSR9<10> must not be set together.

¹CSR9<14:10> are not affected by software reset.

3.2.2.13 Boot ROM Programming Address Register (CSR10–Offset 50H)

The boot ROM programming address register (CSR10) contains the 18-bit boot ROM address.

Figure 3–39 shows the CSR10 register bit field and Table 3–83 describes the bit field.

Figure 3–39 CSR10 Register Bit Field

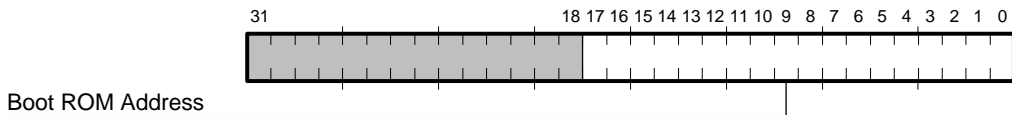

LJ03973A.WMF

Table 3–83 CSR10 Register Bit Field Description

Field	Description
17:0	Boot ROM Address Contains a pointer to the boot ROM.

Table 3–84 lists the access rules for the CSR10 register.

CSR Operation

Table 3–84 CSR10 Register Access Rules

Category	Description
Value after reset	Undefined
Read access rules	—
Write access rules	—

3.2.2.14 General-Purpose Timer and Interrupt Mitigation Control Register (CSR11–Offset 58H)

CSR11 controls the receive and transmit interrupt mitigation and contains a 16-bit general-purpose timer. The general-purpose timer is used mainly by the software driver for timing functions not supplied by the operating system. After this timer is loaded, it starts counting down. The expiration of the timer causes an interrupt in CSR5<11>. If the timer expires and the CON bit is set, the timer will load itself automatically with the last value loaded. The value that is read by the host in this register is the current count value. The timer reading accuracy is ±1 bit.

The timer operation is based on the existing serial clock. The cycle time of the timer depends on the port that is selected. The timer is not active in snooze mode (Section 7.4).

The interrupt mitigation mechanism allows the driver to reduce the number of receive and transmit interrupts, which reduces the CPU utilization for servicing a large number of interrupts. For more information about the interrupt mitigation mechanism, see Section 4.3.3.1.

Figure 3–40 shows the CSR11 register bit fields and Table 3–85 describes the bit fields.

Figure 3–40 CSR11 Register Bit Fields

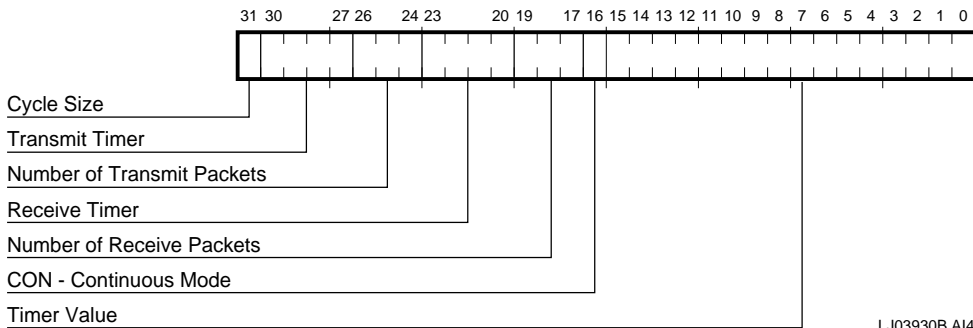

LJ03930B.A14

Table 3–85 CSR11 Register Bit Fields Description

Field	Description
31	<p>Cycle Size¹</p> <p>This field controls the units for the transmit and receive timers. When set, the cycle size is:</p> <ul style="list-style-type: none"> • 10BASE-T/AUI mode—12.8 μs • MII/SYM 100-Mb/s mode—5.12 μs • MII 10-Mb/s mode—51.2 μs <p>When cleared, the cycle size is:</p> <ul style="list-style-type: none"> • 10BASE-T/AUI mode—204.8 μs • MII/SYM 100-Mb/s mode—81.92 μs • MII 10-Mb/s mode—819.2 μs
30:27	<p>Transmit Timer¹</p> <p>Indicates the time in units of “16 * Cycle Size” before issuing a transmit interrupt after packet transmission.</p>
26:24	<p>Number of Transmit Packets¹</p> <p>Indicates the number of transmit packets before issuing a transmit interrupt.</p>
23:20	<p>Receive Timer¹</p> <p>Indicates the time in units of “Cycle Size” before issuing a receive interrupt after packet reception.</p>
19:17	<p>Number of Receive Packets¹</p> <p>Indicates the number of receive packets before issuing a receive interrupt.</p>
16	<p>CON—Continuous Mode</p> <p>When set, the general-purpose timer is in continuous operating mode. When reset, the general-purpose timer is in one-shot operating mode.</p>
15:0	<p>Timer Value</p> <p>Contains the number of iterations of the general-purpose timer. Each iteration duration is:</p> <ul style="list-style-type: none"> 10BASE-T /AUI mode – 204.8 μs. MII/SYM 100-Mb/s mode – 81.92 μs. MII 10-Mb/s mode – 819.2 μs.

¹This field only exists on the 21143–PD and the 21143–TD.

CSR Operation

Table 3–86 lists the access rules for the CSR11 register.

Table 3–86 CSR11 Register Access Rules

Category	Description
Value after reset	FFFE0000H
Read access rules	The values returned from this register’s fields are the current count values of the timers and counters.
Write access rules	—

3.2.2.15 SIA Status Register (CSR12–Offset 60H)

Figure 3–41 shows the CSR12 register bit fields.

Figure 3–41 CSR12 Register Bit Fields

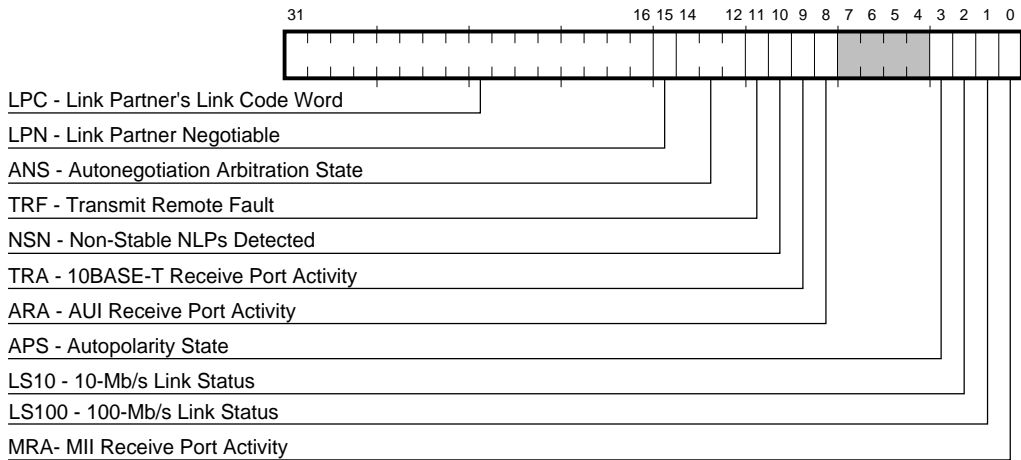

LJ-05120 .AI4

Table 3–87 describes the CSR12 register bit fields.

Table 3–87 CSR12 Register Bit Fields Description

(Sheet 1 of 3)

Field	Description
31:16	LPC—Link Partner’s Link Code Word These bits contain the link partner’s link code word, where bit 16 is S0 (selector field bit 0) and bit 31 is NP (Next Page). Effective only when CSR12<15> is set.

Table 3–87 CSR12 Register Bit Fields Description

(Sheet 2 of 3)

Field	Description
15	<p>LPN—Link Partner Negotiable</p> <p>This bit is set when the link partner is recognized to be a device that implements the autonegotiation algorithm. Effective only when CSR14<7> is set.</p>
14:12	<p>ANS—Autonegotiation Arbitration State</p> <p>The CSR12<14:12> bits reflect the current autonegotiation arbitration state as follows:</p> <ul style="list-style-type: none"> 000—Autonegotiation disable 001—Transmit disable 010—Ability detect 011—Acknowledge detect 100—Complete acknowledge 101—FLP link good; autonegotiation complete 110—Link check <p>When autonegotiation is completed, an ANC interrupt (CSR5<4>) is generated. These bits can also be used to restart the autonegotiation sequence. This is done by writing a pattern of 001 into this field, provided that autonegotiation enable (CSR14<7>) is set. Otherwise, these bits should be written as 0.</p>
11	<p>TRF—Transmit Remote Fault</p> <p>When set, the 21143 sets bit 13 (remote fault bit) in the transmitted link code words. This can be used to inform the link partner that some fault has occurred.</p>
10	<p>NSN—Non-Stable NLPs Detected</p> <p>When set, indicates that the 10BASE-T normal link pulse (NLP) is not stable. The Link Integrity Test passed for a while, but failed later during negotiation. This means that NLPs were recognized on the line, but were not stable enough to cause autonegotiation completion. This bit is cleared by a read transaction. Effective only when CSR14<7> is set.</p>
9	<p>TRA—10BASE-T Receive Port Activity</p> <p>Sets when there is receive activity on the 10BASE-T port. This bit is valid only if port select CSR6<18> is reset. This bit is cleared by writing 1.</p>
8	<p>ARA—AUI Receive Port Activity</p> <p>Sets when there is receive activity on the AUI port. This bit is valid only if port select CSR6<18> is reset. This bit is cleared by writing 1.</p>
3	<p>APS—Autopolarity State</p> <p>When set, the 10BASE-T polarity is positive. When reset, the 10BASE-T polarity is negative. The received bit stream is inverted by the receiver. (Refer to autopolarity enable CSR14<13> and set polarity plus CSR14<14>).</p>

CSR Operation

Table 3–87 CSR12 Register Bit Fields Description

(Sheet 3 of 3)

Field	Description
2	<p>LS10—10-Mb/s Link Status</p> <p>This bit continuously reflects the 10BASE-T link test status. When set, the 10BASE-T link test is in fail state. When reset, the 10BASE-T link test is in pass state. This bit is effective only in 10BASE-T mode, and only when CSR14<8>, Receive Squelch Enable, is set. During link fail, when in 10BASE-T mode, the 21143 does not transmit any packet to the media. However, any queued packets in the transmit list can be closed by the 21143 with the following set:</p> <ul style="list-style-type: none">TDES0<2>—Link failTDES0<10>—No carrierTDES0<11>—Loss of carrier <p>The 21143 moves from the link fail state to the link pass state when it receives a legal link pulse stream or two consecutive packets. The driver receives no indication about these packets. During link fail, when in 10BASE-T mode, the 21143 does not receive any packet from the media. When autonegotiation (CSR14<7>) is set, the LS10 bit is effective only if autonegotiation arbitration state (CSR12<14:12>) is 101 (autonegotiation completed).</p>
1	<p>LS100—100-Mb/s Link Status</p> <p>This bit continuously reflects the 100BASE-TX link test status. When set, the 100BASE-TX link test is in fail state. When reset, the 100BASE-TX link test is in pass state. This status is derived from the sd pin and is effective only when CSR6<23> (PCS function) is set. This bit is effective regardless of the status of CSR6<18> (Port Select) and CSR14<7> (Autonegotiation Enable). When autonegotiation (CSR14<7>) is set, the LS100 bit is effective only if autonegotiation arbitration state (CSR12<14:12>) is 101 (autonegotiation completed).</p>
0	<p>MRA—MII Receive Port Activity</p> <p>Sets when there is receive activity on the MII port and the MII port is selected. This bit is cleared and the MII port is selected by writing 1.</p>

Table 3–88 lists the access rules for the CSR12 register.

Table 3–88 CSR12 Register Access Rules

Category	Description
Value after reset	000000C6H
Read access rules	—
Write access rules	CSR12<0>, CSR12<8>, and CSR12<9> are cleared by writing 1. Writing 0 to these same bits has no effect. Writing to the remainder of the CSR12 bits (except bits 14:11) has no effect.

3.2.2.16 SIA Connectivity Register (CSR13–Offset 68H)

The SIA connectivity register (CSR13) contains the SIA connectivity control bits that permit the interconnection of different sections within the SIA. This allows coverage of the required operation and test options.

Figure 3–42 shows the CSR13 register bit fields, and Table 3–89 describes the bit fields.

Figure 3–42 CSR13 Register Bit Fields

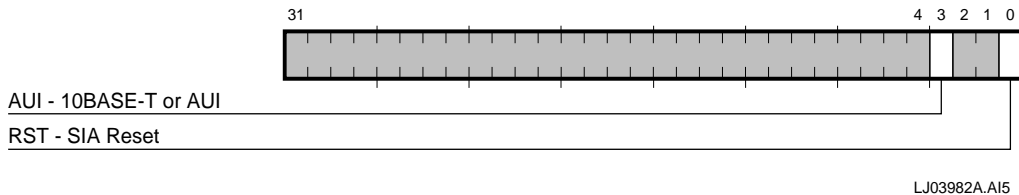

Table 3–89 CSR13 Register Bit Fields Description

Field	Description
3	AUI—10BASE-T or AUI When reset, forces the 21143 to select the 10BASE-T interface. When set to 1, forces the 21143 to select the AUI interface. The selection between 10BASE5 (AUI) and 10BASE2 (BNC) is done by CSR15<3>.
0	RST—SIA Reset When reset, resets all the SIA functions and machines.

Table 3–90 lists the access rules for the CSR13 register.

CSR Operation

Table 3–90 CSR13 Register Access Rules

Category	Description
Value after reset	FFFF0000H
Read access rules	—
Write access rules	—

3.2.2.17 SIA Transmit and Receive Register (CSR14–Offset 70H)

The SIA transmit and receive register (CSR14) configures the SIA transmitter and receiver operating modes. Figure 3–43 shows the CSR14 register bit fields.

Figure 3–43 CSR14 Register Bit Fields

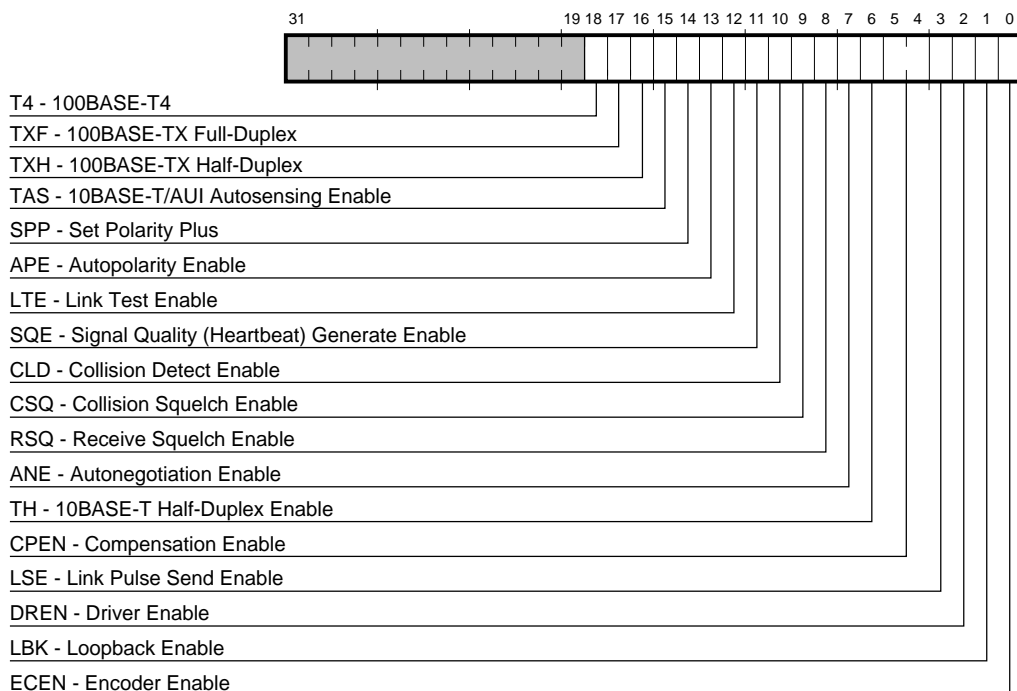

LJ-05121.A14

Table 3–91 describes the bit CSR14 register bit fields.

Table 3–91 CSR14 Register Bit Fields Description

(Sheet 1 of 3)

Field	Description
18	<p>T4—100BASE-T4</p> <p>This bit controls the value of bit 9 in the transmitted link code word. When set, the 21143 advertises its ability to work also in 100BASE-T4 mode. (Bit 9 in the link code word is set.) When clear, the 21143 advertises that no 100BASE-T4 operation is allowed. (Bit 9 in the link code word is cleared.) This bit is meaningful only if CSR14<7> is set.</p>
17	<p>TXF—100BASE-TX Full-Duplex</p> <p>This bit controls the value of bit 8 in the transmitted link code word. When set, the 21143 advertises its ability to work also in 100BASE-TX full-duplex mode. (Bit 8 in the link code word is set.) When clear, the 21143 advertises that no 100BASE-TX full-duplex operation is allowed. (Bit 8 in the link code word is cleared.) This bit is meaningful only if CSR14<7> is set.</p>
16	<p>TXH—100BASE-TX Half-Duplex</p> <p>This bit controls the value of bit 7 in the transmitted link code word. When set, the 21143 advertises its ability to work also in 100BASE-TX half-duplex mode. (Bit 7 in the link code word is set.) When clear, the 21143 advertises that no 100BASE-TX half-duplex operation is allowed. (Bit 7 in the link code word is clear.) This bit is meaningful only if CSR14<7> is set.</p>
15	<p>TAS—10BASE-T/AUI Autosensing Enable</p> <p>When set, the 21143 monitors its 10BASE-T and AUI ports. The selected port operation is not affected. See Section 6.2.7. When cleared, the 21143 monitors only the port that is selected for operation AUI or 10BASE-T according to CSR13<3>.</p>
14	<p>SPP—Set Polarity Plus</p> <p>When reset and autopolarity enable (CSR14<13>) is reset, the polarity of the incoming data is switched. This feature can be used by the driver to reverse polarity of incoming packets; otherwise, this bit should be set. This bit is valid only in 10BASE-T mode.</p>
13	<p>APE—Autopolarity Enable</p> <p>When set and link test enable CSR14<12> is also set, the autopolarity function logic is enabled (Section 6.2.7). When reset, the polarity is determined by set polarity plus (CSR14<14>). When link test enable (CSR14<12>) is reset, this bit (CSR14<13>) should be also reset. This bit is valid only in 10BASE-T mode.</p>

CSR Operation

Table 3–91 CSR14 Register Bit Fields Description

(Sheet 2 of 3)

Field	Description
12	LTE—Link Test Enable This bit is meaningful only for the 10BASE-T port. When set, the link test function logic is enabled. Resetting this bit forces the link test function to link pass state.
11	SQE—Signal Quality (Heartbeat) Generate Enable Controls the signal quality (SQE) generator ability to imitate external medium attachment unit (MAU) behavior. When set, a short heartbeat signal is generated after the conclusion of a transmitted packet. In 10BASE-T mode, SQE (CSR14<11>) should be set; otherwise, a heartbeat fail (TDES0<7>) is set. In AUI mode, SQE (CSR14<11>) should be reset.
10	CLD—Collision Detect Enable When set, the collision detect logic is enabled.
9	CSQ—Collision Squelch Enable When set, the AUI collision receivers are active. This bit is valid only when AUI is selected.
8	RSQ—Receive Squelch Enable When set, the AUI or 10BASE-T receivers are active in accordance with the selected mode. Note that when port autosensing is enabled, the AUI and 10BASE-T receivers are active simultaneously.
7	ANE—Autonegotiation Enable When set, the 21143 performs an autonegotiation with the link partner to determine the operation mode (Section 6.6). When reset, autonegotiation is disabled. Autonegotiation can be performed only when in 10BASE-T mode.
6	TH—10BASE-T Half-Duplex Enable This bit controls the value of bit 5 in the transmitted link code word. When set, the 21143 advertises its ability to also work in 10BASE-T half-duplex mode. (Bit 5 in the link code word is set.) When clear, the 21143 advertises that no 10BASE-T half-duplex operation is allowed. (Bit 5 in the link code word is cleared.) 10BASE-T full-duplex ability advertisement (bit 6 in the transmitted link code word) is controlled by CSR6<9> Full Duplex Mode. This bit is meaningful only if CSR14<7> is set.
5:4	CPEN—Compensation Enable Table 3–93 defines twisted-pair compensation behavior. These bits are valid only in 10BASE-T mode.
3	LSE—Link Pulse Send Enable This bit is meaningful only for the 10BASE-T port. When set, the link pulse generator is enabled.

Table 3–91 CSR14 Register Bit Fields Description

(Sheet 3 of 3)

Field	Description
2	DREN—Driver Enable When set, the transmit SIA driver is enabled for AUI or 10BASE-T operation. When reset, the transmit driver is disabled, preventing the data and link pulse transmission to the external wires.
1	LBK—Loopback Enable Enables loopback operation in SIA (Table 3–100 and Section 6.4.3). In AUI mode, this bit should be reset.
0	ECEN—Encoder Enable When set, the transmit data encoder is enabled, and the encoded data is transferred to the output drivers. When reset, the transmit data encoder is disabled, and the encoded data is blocked from propagating to the output drivers.

Table 3–92 lists the access rules for the CSR14 register.

Table 3–92 CSR14 Register Access Rules

Category	Description
Value after reset	FFFFFFFFH
Read access rules	—
Write access rules	—

CSR Operation

Table 3–93 lists the compensation field (CSR14<5:4>) definitions.

Table 3–93 Twisted-Pair Compensation Behavior

CSR14<5:4> Value	Transmitter Output
00, 01	Compensation disabled mode—Twisted-pair driver does not compensate for 10-MHz versus 5-MHz media attenuation. (Differential voltages are bound between 1.5 V and 2.1 V.)
10	High power mode—Twisted-pair driver drives only high-differential voltage (between 2.2 V and 2.8 V).
11	Normal compensation mode—Driver compensates for 10-MHz versus 5-MHz media attenuation by driving high-differential voltage for transients and by driving low if the signal is stable for more than 50 ns.

3.2.2.18 SIA and General-Purpose Port Register (CSR15–Offset 78H)

Figure 3–44 shows the CSR15 register bit fields. CSR15 is divided into two sections: the SIA general register (CSR15<15:0>) and the general-purpose port register (CSR15<31:16>). Appendix E describes the general-purpose port programming procedures.

Figure 3–44 CSR15 Register Bit Fields

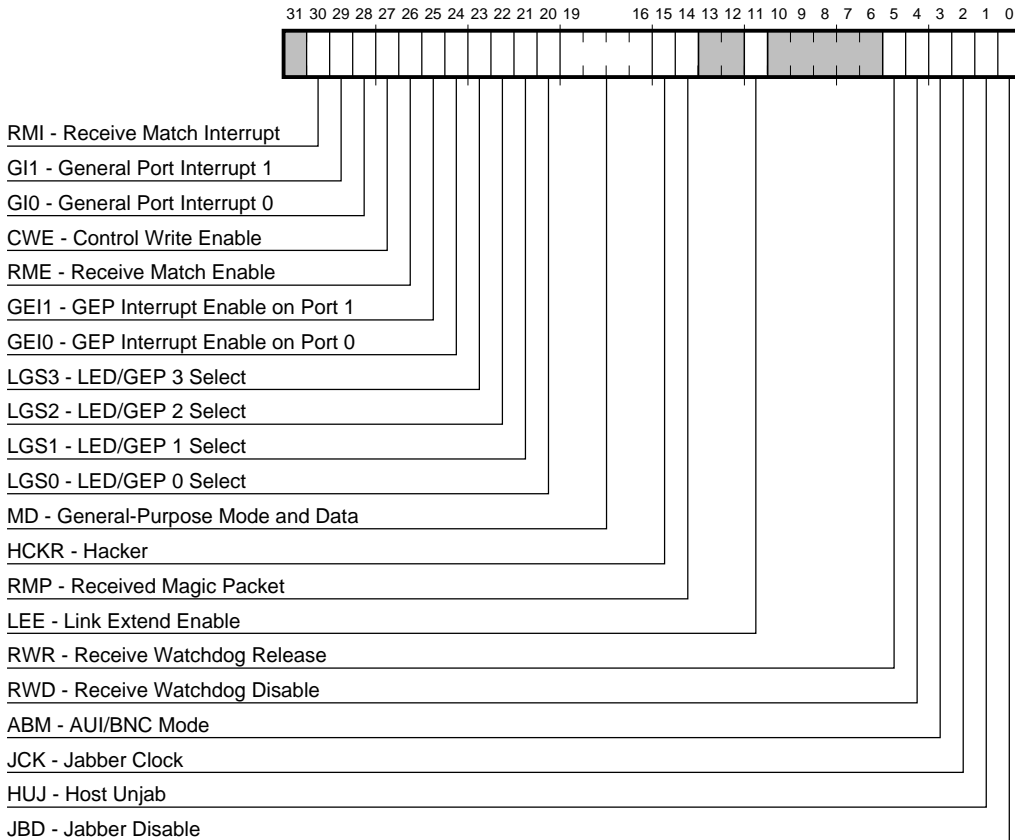

FM-05632.A14

CSR Operation

Table 3–94 describes the bit fields.

Table 3–94 CSR15 Register Bit Fields Description

(Sheet 1 of 4)

Field	Description
30	RMI—Receive Match Interrupt Indicates that a packet has passed address filtering. When this bit is set and the receive match interrupt is enabled (CSR15<26>=1), the general-purpose port interrupt (CSR5<26>) is set. This bit is cleared when reading CSR15. This bit is not automatically cleared when general-purpose port interrupt (CSR5<26>) is cleared.
29	GII—General Port Interrupt 1 Indicates that gep<1> has changed state. This bit is set only when gep<1> is programmed to be a general-purpose input port. When this bit is set and the general-purpose port interrupt is enabled (CSR15<24>=1), the general-purpose port interrupt (CSR5<26>) is set. This bit is cleared when reading CSR15. This bit is not automatically cleared when general-purpose port interrupt (CSR5<26>) is cleared.
28	GI0—General Port Interrupt 0 Indicates that gep<0> has changed state. This bit is set only when gep<0> is programmed to be a general-purpose input port. When this bit is set and the general-purpose port interrupt 0 is enabled (CSR15<24>=1), the general-purpose port interrupt (CSR5<26>) is set. This bit is cleared when reading CSR15. This bit is not automatically cleared when general-purpose port interrupt (CSR5<26>) is cleared.
27	CWE—Control Write Enable When CSR15 is written and CSR15<27> value is 1, the general-purpose control bits will be written. The general-purpose control bits include interrupt enables (CSR15<26:24>), LED/GEP selects (CSR15<23:20>), and general-purpose pin directions (CSR15<19:16>). When CSR15 is written and CSR15<27> value is 0, only general-purpose data (CSR15<19:16>) will be written.
26	RME—Receive Match Enable When this bit is set, receive match interrupt (CSR15<30>) is enabled. When this bit is reset, the interrupt is disabled. After a hardware or software reset, the interrupt is disabled.
25	GEI1—GEP Interrupt Enable on Port 1 When this bit is set, the interrupt from pin gep<1> (CSR15<29>) is enabled. When this bit is reset, the interrupt is disabled. After a hardware or software reset, the interrupt is disabled.

Table 3–94 CSR15 Register Bit Fields Description

(Sheet 2 of 4)

Field	Description
24	<p>GEI0—GEP Interrupt Enable on Port 0</p> <p>When this bit is set, the interrupt from gép<0> (CSR15<28>) is enabled. When this bit is reset, the interrupt is disabled. After a hardware or software reset, the interrupt is disabled.</p>
23	<p>LGS3—LED/GEP 3 Select</p> <p>This bit selects either the LED or gép<3> function for 21143 pin number 103. When this bit is set, the LED function is selected that, according to MiscHwOptions<0> (Gep3LedDefinition) bit in the serial ROM, provides an LED indicating either: –Network link integrity state for 10BASE-T or 100BASE-TX.¹ –Both network activity and network link integrity state.² When this bit is reset, the gép<3> function is selected. If the pin was designated to be an input pin, it functions as an input link status pin for OnNow support.² If the pin was designated to be an output pin, it functions as a general-purpose port that performs output functions.³ After a hardware or software reset, the gép<3> function is selected.</p>
22	<p>LGS2—LED/GEP 2 Select</p> <p>This bit selects either the rcv_match or gép<2> function for 21143 pin number 102. When this bit is set, the rcv_match function is selected, which provides a LED indicating the status of the address recognition (sets when a packet passes address recognition). When this bit is reset, the gép<2> function is selected. The gép<2> pin is a general-purpose port. After a hardware or software reset, the gép<2> function is selected.</p>
21	<p>LGS1—LED/GEP 1 Select</p> <p>This bit selects either the activ or gép<1> function for 21143 pin number 101. When this bit is set, the activ function is selected, which provides a LED indicating receive or transmit activity on the selected port (sets when there is receive or transmit activity on the selected port). When this bit is reset, the gép<1> function is selected. The gép<1> pin is a general-purpose port. After a hardware or software reset, the gép<1> function is selected.</p>
20	<p>LGS0—LED/GEP 0 Select</p> <p>This bit selects either the auí_bnc or gép<0> function for 21143 pin number 100. When this bit is set, the auí_bnc function is selected, which provides a control line to select either 10BASE5 (AUI) or 10BASE2 (BNC) as programmed by CSR15<3>. When this bit is reset, the gép<0> function is selected. The gép<0> pin is a general-purpose port. After a hardware or software reset, the gép<0> function is selected.</p>

CSR Operation

Table 3–94 CSR15 Register Bit Fields Description

(Sheet 3 of 4)

Field	Description
19:16	MD—General-Purpose Mode and Data When CSR15<27> is set, the value that is written by the host to CSR15<19:16> directs pins gep<3:0> to act as input or output pins (CSR15<19> controls pin gep<3> and so on). A 1 directs the pin to be an output while a 0 directs the pin to be an input. The value that is driven by a gep pin that was directed to be an output is cleared when CSR15<27> is set. When CSR15<27> is reset, the values written to CSR15<19:16> are the values that will be driven on pins gep<3:0> , respectively. This is only true for the pins that are configured as output pins. After the 21143 is reset, all gep pins become input pins. If gep<1:0> pins are selected as input pins, an interrupt occurs when either of these bits change state from 1 to 0 or 0 to 1 (provided that the interrupt CSR15<25:24> is enabled). The application of the general-purpose pins in board design should be correlated with the way the port driver software is using it. Reading CSR15<19:16> returns the values of pins gep<3:0> .
15	HCKR—Hacker When set, indicates that 16 packets have been received with a matching remote wake-up-LAN format, including a good CRC but with a nonmatching password.
14	RMP—Received Magic Packet When set, indicates that a Magic Packet has been received. Writing a 1 to this bit will clear it. It is unaffected by any reset.
11	LEE—Link Extend Enable When set, the 21143 reports link detection on its 100BASE-TX symbol port only if its sd pin (117) is asserted for at least 1.2 ms. ² When cleared, the 21143 reports link detection on its 100BASE-TX symbol port only if its sd pin (117) is asserted for at least 330 µs.
5	RWR—Receive Watchdog Release Defines the time interval from receive watchdog expiration until reenabling the receive channel (<i>no carrier</i>). When set, the receive watchdog is released 40- to 48-bit-times from the last carrier deassertion. When reset, the receive watchdog is released 16- to 24-bit-times from the last carrier deassertion.
4	RWD—Receive Watchdog Disable When set, the receive watchdog counter is disabled. When clear, receive carriers longer than 2560 bytes are guaranteed to cause the watchdog counter to timeout. Packets shorter than 2048 bytes are guaranteed to pass.

Table 3–94 CSR15 Register Bit Fields Description

(Sheet 4 of 4)

Field	Description
3	<p>ABM—AUI/BNC Mode</p> <p>This bit is used by the driver to select either AUI or BNC mode. When set, AUI (10BASE5) is selected. When clear, BNC (10BASE2) is selected. The value programmed to this bit is the value that is driven in the gcp<0>/aui_bnc pin when it is set to au_i_bnc. This pin is used mainly to enable the external BNC transceiver in 10BASE2 mode.</p>
2	<p>JCK—Jabber Clock</p> <p>When set, transmission is cut after 2048 bytes to 2560 bytes are transmitted. When reset, transmission is cut after 26 ms to 33 ms at a 10-Mb/s line speed or after 2.6 ms to 3.3 ms at a 100-Mb/s line speed.</p>
1	<p>HUJ—Host Unjab</p> <p>Defines the time interval between transmit jabber expiration until reenabling of the transmit channel. When set, the transmit channel is released immediately after the jabber expiration. When reset, the transmit jabber is released 365 ms to 420 ms after jabber expiration at a 10-Mb/s line speed or 36.5 ms to 42.0 ms after jabber expiration at a 100-Mb/s line speed.</p>
0	<p>JBD—Jabber Disable</p> <p>When set, the transmit jabber function is disabled.</p>

¹The 100BASE-TX link indication feature is only supported on the 21143–PD and the 21143–TD.

²This feature is only supported on the 21143–PD and the 21143–TD.

³Can also be used for general-purpose input functions on the 21143–PB, 21143–TB, 21143–PC, and the 21143–TC.

Table 3–95 lists the access rules for the CSR15 register.

Table 3–95 CSR15 Register Access Rules

Category	Description
Value after reset	8FFX0000H
Read access rules	CSR15<27:20> are write-only bits.
Write access rules	—

CSR Operation

3.2.2.19 SIA and MII Operating Modes

Table 3–96 through Table 3–100 list the programming of the different operating modes in the 21143 using CSR6, CSR13, CSR14, and CSR15. The states of operating mode CSR6<11:10>, full-duplex mode CSR6<9>, and port select CSR6<18> are also identified. Appendix D describes the port selection procedure.

Table 3–96 describes the programming of MII/SYM operating modes.

Table 3–96 Programming MII/SYM Operating Modes

Mode	CSR13<15:0>	CSR14<15:0>	CSR15<15:0>	CSR6<PS,FD>	CSR6<OM>
Half-duplex	0000	0000	0008	1,0	00
Full-duplex	0000	0000	0008	1,1	00
Internal loopback	0000	0000	0008	1,0	01
External loopback	0000	0000	0008	1,0	10

Table 3–97 describes the programming of 10BASE-T, AUI, and BNC operating modes with autosensing disabled and autonegotiation disabled.

Table 3–97 Programming 10BASE-T, AUI, and BNC Operating Modes with Autosensing Disabled and Autonegotiation Disabled

(Sheet 1 of 2)

Mode	CSR13<15:0>	CSR14<15:0>	CSR15<15:0>	AUI_BNC Pin	CSR6<PS,FD>	CSR6<OM>
10BASE-T forced to half- duplex	0001	7F3F	0008	High (AUI)	0,0	00
10BASE-T forced to full- duplex	0001	7F3D	0008	High (AUI)	0,1	00
10BASE-T internal loopback	0001	7A3F	0008	High (AUI)	0,0	10
10BASE-T external loopback	0001	7B3D	0008	High (AUI)	0,0	10

Table 3–97 Programming 10BASE-T, AUI, and BNC Operating Modes with Autosensing Disabled and Autonegotiation Disabled *(Sheet 2 of 2)*

Mode	CSR13<15:0>	CSR14<15:0>	CSR15<15:0>	AUI_BNC Pin	CSR6<PS,FD>	CSR6<OM>
BNC (10BASE2)	0009	4705	0006	Low (BNC)	0,0	00
BNC (10BASE2) external loopback	0009	4705	0006	Low (BNC)	0,0	10
AUI (10BASE5)	0009	4705	000E	High (AUI)	0,0	00
AUI (10BASE5) external loopback	0009	4705	000E	High (AUI)	0,0	10
Internal loopback in MAC level	0009	0000	0019	High (AUI)	0,0	01

Table 3–98 describes the programming of 10BASE-T, AUI, and BNC operating modes with autosensing disabled and autonegotiation enabled.

Table 3–98 Programming 10BASE-T, AUI, and BNC Operating Modes with Autosensing Disabled and Autonegotiation Enabled

Mode	CSR13<15:0>	CSR14<15:0>	CSR15<15:0>	AUI_BNC Pin	CSR6<PS,FD>	CSR6<OM>
10BASE-T advertising half- and full-duplex	0001	7FFF	0008	High (AUI)	0,1	00
10BASE-T advertising full-duplex	0001	7FBF	0008	High (AUI)	0,1	00
10BASE-T advertising half-duplex	0001	7FFF	0008	High (AUI)	0,0	00

CSR Operation

Table 3–99 describes the programming of 10BASE-T, AUI, and BNC operating modes with autosensing enabled and autonegotiation disabled.

Table 3–99 Programming 10BASE-T, AUI, and BNC Operating Modes with Autosensing Enabled and Autonegotiation Disabled

Mode	CSR13<15:0>	CSR14<15:0>	CSR15<15:0>	AUI_BNC Pin	CSR6<PS,FD>	CSR6<OM>
10BASE-T forced to half-duplex	0001	FF3F	0008	High (AUI)	0,0	00
10BASE-T forced to full-duplex	0001	FF3D	0008	High (AUI)	0,1	00
BNC (10BASE2)	0009	F73D	0006	Low (BNC)	0,0	00
AUI (10BASE5)	0009	F73D	000E	High (AUI)	0,0	00

Table 3–100 describes the programming of 10BASE-T, AUI, and BNC operating modes with autosensing enabled and autonegotiation enabled.

Table 3–100 Programming 10BASE-T, AUI, and BNC Operating Modes with Autosensing Enabled and Autonegotiation Enabled

(Sheet 1 of 2)

Mode	CSR13<15:0>	CSR14<15:0>	CSR15<15:0>	AUI_BNC Pin	CSR6<PS,FD>	CSR6<OM>
10BASE-T advertising half- and full-duplex	0001	FFFF	0008	High (AUI)	0,1	00
10BASE-T advertising full-duplex	0001	FFBF	0008	High (AUI)	0,1	00
10BASE-T advertising half-duplex	0001	FFFF	0008	High (AUI)	0,0	00

Table 3–100 Programming 10BASE-T, AUI, and BNC Operating Modes with Autosensing Enabled and Autonegotiation Enabled *(Sheet 2 of 2)*

Mode	CSR13<15:0>	CSR14<15:0>	CSR15<15:0>	AUI_BNC Pin	CSR6<PS,FD>	CSR6<OM>
BNC (10BASE2) advertising half- and full-duplex on TP	0009	F7FD	0006	Low (BNC)	0,1	00
BNC (10BASE2) advertising full-duplex only on TP	0009	F7BD	0006	Low (BNC)	0,1	00
BNC (10BASE2) advertising half- duplex only on TP	0009	F7FD	0006	Low (BNC)	0,0	00
AUI (10BASE5) advertising half- and full-duplex on TP	0009	F7FD	000E	High (AUI)	0,1	00
AUI (10BASE5) advertising full-duplex only on TP	0009	F7BD	000E	High (AUI)	0,1	00
AUI (10BASE5) advertising half- duplex only on TP	0009	F7FD	000E	High (AUI)	0,0	00

CardBus Status Changed Registers

3.3 CardBus Status Changed Registers

The 21143 implements four Status Changed registers.¹ The Status Changed registers are accessed by the CardBus system software; they are typically not accessed by the 21143 driver. These registers are mapped only to the memory address space and not to the I/O address space.

These registers affect the operation of the 21143 only if both:

- Func0_HwOptions<7> bit (RealSTSCHG) in the serial ROM is set.
- The FER or the FEMR were accessed with a write operation after a power-up reset.

Otherwise, these registers are not valid and do not affect the behavior of the 21143.

Note: Reserved bits are shaded and should be written with 0. Failing to do this could cause incompatibility problems with a future version of the 21143. Reserved bits are undefined on read access.

Table 3–101 lists the definitions and addresses for the CardBus Status Changed registers.

Table 3–101 CardBus Status Changed Register Mapping

Register	Meaning	Offset from CSR Base Address (CBIO and CBMA)
FER	Function event register	80H
FEMR	Function event mask register	84H
FPSR	Function present state register	88H
FFER	Function force event register	8CH

3.3.1 Function Event Register (FER–Offset 80H)

This register is the CardBus Status Changed function event register, which is used for reporting of interrupt pending and power-management event detection in a CardBus system.

¹These registers only exist in the 21143–PD and the 21143–TD.

CardBus Status Changed Registers

Figure 3–45 shows the FER register bit fields and Table 3–102 describes the bit fields.

Figure 3–45 FER Register Bit Fields

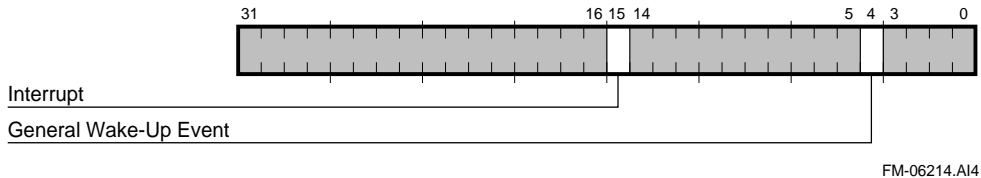

Table 3–102 FER Register Bit Fields Description

Field	Description
15	Interrupt This bit is set when there is an interrupt pending. This bit is cleared by write 1.
4	General Wake-Up Event This bit is set when the 21143 has detected a power management event. This bit is cleared upon power-up reset and by write 1. It is unaffected by either hardware or software reset. When the PME_Status bit in the PCI configuration is cleared, this bit is automatically cleared as well.

Table 3–103 lists the access rules for the FER register.

Table 3–103 FER Register Access Rules

Category	Description
Value after reset	Undefined for reserved bits; 0 for bits that are not reserved.
Read access rules	—
Write access rules	These register bits are cleared by writing 1; writing 0 has no effect.

CardBus Status Changed Registers

3.3.2 Function Event Mask Register (FEMR—Offset 84H)

This register is the CardBus Status Changed function event mask register, which controls the assertion of the signals **int_1** and **gpc<2>/rcv_match/wake** in a CardBus system.

Figure 3–46 shows the FEMR register bit fields and Table 3–104 describes the bit fields.

Figure 3–46 FEMR Register Bit Fields

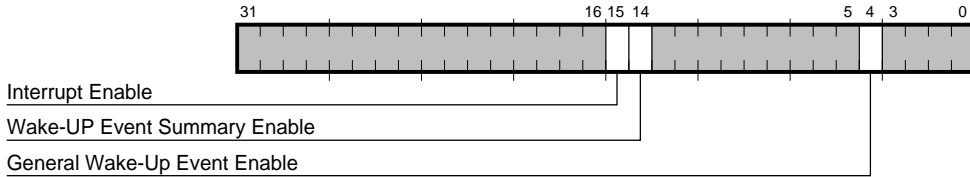

FM-06215.A14

Table 3–104 FEMR Register Bit Fields Description

Field	Description
15	Interrupt Enable When set, enables the assertion of the interrupt pin (int_1).
14	Wake-Up Event Summary Enable When set together with the General Wake-Up Event Enable bit (FEMR<4>), enables the assertion of the gpc<2>/rcv_match/wake pin. Note: To disable the assertion of the gpc<2>/rcv_match/wake pin, the PME_Enable bit in the PCI configuration register (CPMC<8>) must be cleared as well. This bit is cleared only upon a power-up reset.
4	General Wake-Up Event Enable When set together with the Wake-Up Event Summary Enable bit (FEMR<14>), enables the assertion of the gpc<2>/rcv_match/wake pin. Note: To disable the assertion of the gpc<2>/rcv_match/wake pin, the PME_Enable bit in the PCI configuration register (CPMC<8>) must be cleared as well. This bit is cleared only upon a power-up reset.

Table 3–105 lists the access rules for the FEMR register.

Table 3–105 FEMR Register Access Rules

Category	Description
Value after reset	Undefined for reserved bits; 0 for bits that are not reserved.
Read access rules	—
Write access rules	These register bits are cleared by writing 1; writing 0 has no effect.

3.3.3 Function Present State Register (FPSR—Offset 88H)

This register is the CardBus Status Changed function present state register, which is used for reporting the present state of the **int_1** and the **gep<2>/rcv_match/wake** pins in a CardBus system.

Figure 3–47 shows the FPSR register bit fields and Table 3–106 describes the bit fields.

Figure 3–47 FPSR Register Bit Fields

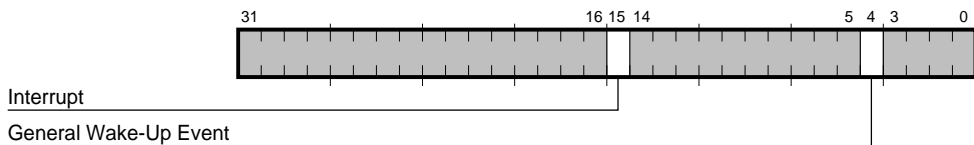

FM-06216.AI4

CardBus Status Changed Registers

Table 3–106 FPSR Register Bit Fields Description

Field	Description
15	Interrupt This bit reflects the state of the interrupt line. It is set when all of the following conditions exist: <ul style="list-style-type: none">–CSR5<15> is set or CSR5<16> is set.–The 21143 is in the D0 power state.–FEMR<15> is set or Func0_HwOptions<7> (RealSTSCHG) bit in the serial ROM is cleared.
4	General Wake-Up Event Reflects the current state of the wake-up event. This bit is cleared when either the General Wake-Up Event in the function event register is cleared, or when the PME_Status bit in the CPMC is cleared. This bit is cleared only upon a power-up reset.

Table 3–107 lists the access rules for the FPSR register.

Table 3–107 FPSR Register Access Rules

Category	Description
Value after reset	Undefined for reserved bits; 0 for bits that are not reserved.
Read access rules	—
Write access rules	This is a read-only register.

3.3.4 Function Force Event Register (FFER–Offset 8CH)

This register is the CardBus Status Changed function force event register, which is used to force the value of the interrupt and the general wake-up event bits in the function event register to a 1.

Figure 3–48 shows the FFER register bit fields and Table 3–108 describes the bit fields.

CardBus Status Changed Registers

Figure 3–48 FFER Register Bit Fields

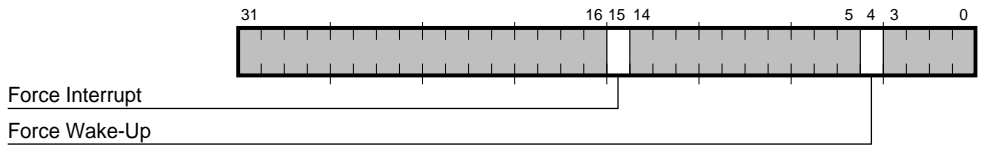

FM-06217.AI4

Table 3–108 FFER Register Bit Fields Description

Field	Description
15	<p>Force Interrupt</p> <p>Writing 1 to this bit sets the Interrupt field in FER<15>, but not in FPSR<15>. If the interrupt is enabled, the 21143 also asserts the int_1 pin. Writing 0 has no effect.</p>
4	<p>Force Wake-Up</p> <p>Writing 1 to this bit sets the wake-up event field in FER<4>, but not in FPSR<4>. If the wake-up event is enabled, the 21143 also asserts the gep<2>/rcv_match/wake pin. Writing 0 has no effect. This bit is cleared only upon a power-up reset.</p>

Table 3–109 lists the access rules for the FFER register.

Table 3–109 FFER Register Access Rules

Category	Description
Value after reset	Undefined for reserved bits; 0 for bits that are not reserved.
Read access rules	This is a write-only register.
Write access rules	—

Host Communication

This chapter describes descriptor lists and data buffers, which are collectively called the host communication area, that manage the actions and status related to buffer management. Commands and signals that control the functional operation, receive and transmit processes, interrupt handling, and the initialization sequence of the 21143 are also described.

Note: All shaded bits in the figures in this chapter are reserved and should be written by the driver as zero.

4.1 Data Communication

The 21143 and the driver communicate through the two following data structures:

- Control and status registers (CSRs), described in Chapter 3.
- Descriptor lists and data buffers, described in this chapter.

4.2 Descriptor Lists and Data Buffers

The 21143 transfers received data frames to the receive buffers in host memory and transmits data from the transmit buffers in host memory. Descriptors that reside in the host memory act as pointers to these buffers.

There are two descriptor lists, one for receive and one for transmit. The base address of each list is written into CSR3 and CSR4, respectively. A descriptor list is forward linked (either implicitly or explicitly). The last descriptor may point back to the first entry to create a ring structure. Explicit chaining of descriptors is accomplished by setting the second address chained in both the receive and transmit descriptors RDES1<24> and TDES1<24>. The descriptor lists reside in the host *physical*

Descriptor Lists and Data Buffers

memory address space. Each descriptor can point to a maximum of two buffers. This enables two buffers to be used, physically addressed, and not contiguous in memory (Figure 4–1).

A data buffer consists of either an entire frame or part of a frame, but it cannot exceed a single frame. Buffers contain only data; buffer status is maintained in the descriptor. Data chaining refers to frames that span multiple data buffers. Data chaining can be enabled or disabled. Data buffers reside in host *physical* memory space.

Figure 4–1 Descriptor Ring and Chain Structure Examples

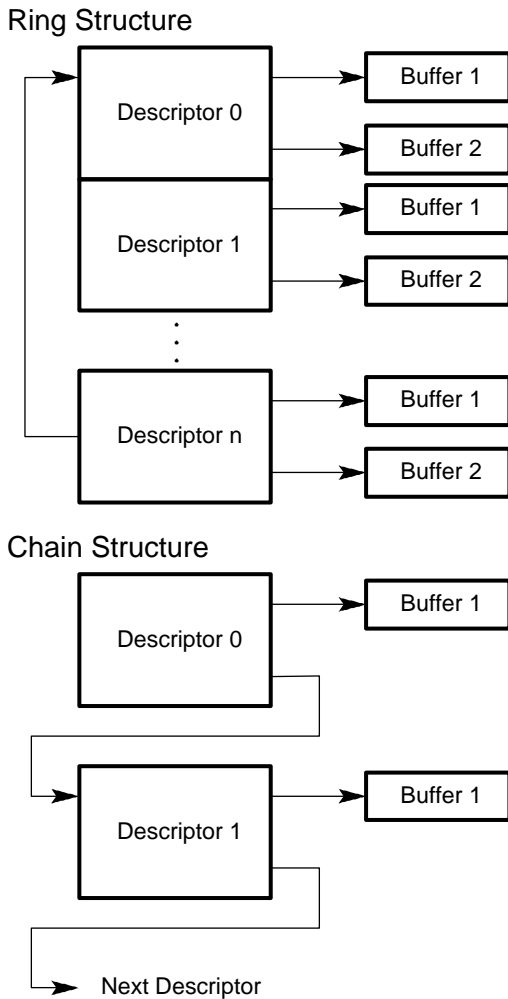

LJ-04096.WMF

4.2.1 Receive Descriptors

Figure 4–2 shows the receive descriptor format.

Note: Descriptors and receive buffers addresses must be longword aligned.

Descriptor Lists and Data Buffers

Providing two buffers, two byte-count buffers, and two address pointers in each descriptor enables the adapter port to be compatible with various types of memory-management schemes.

Figure 4–2 Receive Descriptor Format

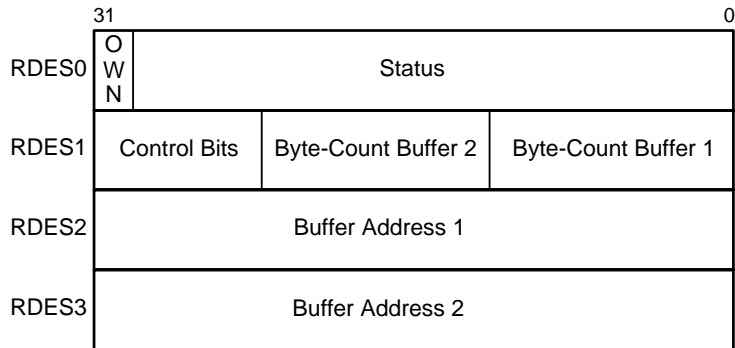

MLO10318.WMF

Descriptor Lists and Data Buffers

4.2.1.1 Receive Descriptor 0 (RDES0)

RDES0 contains the received frame status, the frame length, and the descriptor ownership information. Figure 4–3 shows the RDES0 bit fields.

Figure 4–3 RDES0 Bit Fields

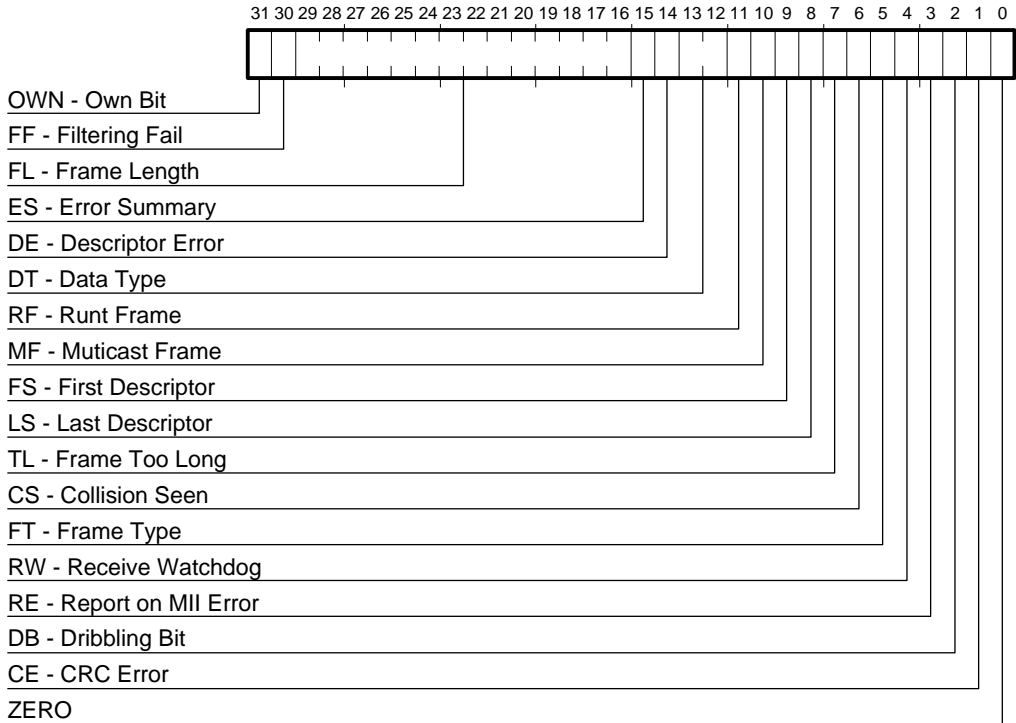

LJ04485A.WMF

Descriptor Lists and Data Buffers

Table 4–1 describes the RDES0 bit fields.

Table 4–1 RDES0 Bit Fields Description

(Sheet 1 of 4)

Field	Description
31	OWN—Own Bit When set, indicates that the descriptor is owned by the 21143. When reset, indicates that the descriptor is owned by the host. The 21143 clears this bit either when it completes the frame reception or when the buffers that are associated with this descriptor are full.
30	FF—Filtering Fail When set, indicates that the frame failed the address recognition filtering. This bit can be set only when receive all (CSR6<30>) is set. Otherwise, this bit is reset. This bit is valid only when last descriptor (RDES0<8>) is set and when the received frame is 64 bytes or longer.
29:16	FL—Frame Length Indicates the length, in bytes, of the received frame that was transferred into host memory, including the cyclic redundancy check (CRC). Normally, this is also the length in bytes of the frame received from the network. In the case of receive timeout, the length of the frame on the network is longer. This field is valid only when last descriptor (RDES0<8>) is set and descriptor error (RDES0<14>) is reset.
15	ES—Error Summary Indicates the logical OR of the following RDES0 bits: RDES0<1>—CRC error RDES0<6>—Collision seen RDES0<7>—Frame too long RDES0<11>—Runt frame RDES0<14>—Descriptor error This bit is valid only when last descriptor (RDES0<8>) is set.
14	DE—Descriptor Error When set, indicates a frame truncation caused by a frame that does not fit within the current descriptor buffers, and that the 21143 does not own the next descriptor. The frame is truncated. This bit is valid only when last descriptor (RDES0<8>) is set.

Table 4–1 RDES0 Bit Fields Description

(Sheet 2 of 4)

Field	Description
13:12	<p>DT—Data Type</p> <p>Indicates the type of frame the buffer contains:</p> <ul style="list-style-type: none"> 00—Serial received frame. 01—Internal loopback frame. 10—External loopback frame or serial received frame. The 21143 does not differentiate between loopback and serial received frames; therefore, this information is global and reflects only the operating mode (CSR6<11:10>). 11—Reserved. <p>This field is valid only when last descriptor (RDES0<8>) is set.</p>
11	<p>RF—Runt Frame</p> <p>When set, indicates that this frame was damaged by a collision or premature termination before the collision window had passed. Runt frames are passed on to the host only if the pass bad frames bit (CSR6<3>) is set.</p> <p>This bit is valid only when last descriptor (RDES0<8>) is set.</p>
10	<p>MF—Multicast Frame</p> <p>When set, indicates that this frame has a multicast address.</p> <p>This bit is valid only when last descriptor (RDES0<8>) is set.</p>
9	<p>FS—First Descriptor</p> <p>When set, indicates that this descriptor contains the first buffer of a frame.</p> <p>If the buffer size of the first buffer is 0, the second buffer contains the beginning of the frame. If the buffer size of the second buffer is also 0, the second descriptor contains the beginning of the frame.</p>
8	<p>LS—Last Descriptor</p> <p>When set, indicates that the buffers pointed to by this descriptor are the last buffers of the frame.</p>
7	<p>TL—Frame Too Long</p> <p>When set, indicates that the frame length exceeds the maximum Ethernet-specified size of 1518 bytes.</p> <p>This bit is valid only when last descriptor (RDES0<8>) is set.</p> <p>Note: Frame too long is only a frame length indication and does not cause any frame truncation.</p>

Descriptor Lists and Data Buffers

Table 4–1 RDES0 Bit Fields Description

(Sheet 3 of 4)

Field	Description
6	<p>CS—Collision Seen</p> <p>When set, indicates that the frame was damaged by a collision that occurred after the 64 bytes following the start frame delimiter (SFD). This is a late collision.</p> <p>This bit is valid only when last descriptor (RDES0<8>) is set.</p>
5	<p>FT—Frame Type</p> <p>When set, indicates that the frame is an Ethernet-type frame (frame length field is greater than 1500 bytes). When clear, indicates that the frame is an IEEE 802.3 frame.</p> <p>This bit is not valid for runt frames of less than 14 bytes.</p> <p>This bit is valid only when last descriptor (RDES0<8>) is set.</p>
4	<p>RW—Receive Watchdog</p> <p>When set, indicates that the receive watchdog timer expired while receiving the current packet with length greater than 2048 bytes through 2560 bytes. Receive watchdog timeout (CSR5<9>) is set.</p> <p>When RDES0<4> is set, the frame length field in RDES0<29:16> is not valid.</p> <p>This bit is valid only when last descriptor (RDES0<8>) is set.</p>
3	<p>RE—Report on MII Error</p> <p>When set, indicates that a receive error in the physical layer was reported during the frame reception. This bit is valid only if the packet was received on the MII/SYM port and when last descriptor (RDES0<8>) is set.</p>
2	<p>DB—Dribbling Bit</p> <p>When set, indicates that the frame contained a noninteger multiple of 8 bits. This error is reported only if the number of dribbling bits in the last byte is 4 in MII operating mode, or at least 3 in 10-Mb/s serial operating mode. This bit is not valid if collision seen (RDES0<6>) is set. If set, and the CRC error (RDES0<1>) is reset, then the packet is valid.</p> <p>This bit is valid only when last descriptor (RDES0<8>) is set.</p>

Table 4–1 RDES0 Bit Fields Description

(Sheet 4 of 4)

Field	Description
1	<p>CE—CRC Error</p> <p>When set, indicates that a cyclic redundancy check (CRC) error occurred on the received frame. This bit is also set when the mii_err pin is asserted during the reception of a receive packet even though the CRC may be correct. This bit is not valid if one of the following conditions exist:</p> <ul style="list-style-type: none"> –The received frame is a runt frame –A collision occurred while the packet was being received –A watchdog timeout occurred while the packet was being received <p>This bit is valid only when last descriptor (RDES0<8>) is set.</p>
0	<p>ZERO</p> <p>This bit is always zero for a packet with legal length.</p>

4.2.1.2 Receive Descriptor 1 (RDES1)

Figure 4–4 shows the RDES1 bit fields.

Figure 4–4 RDES1 Bit Fields

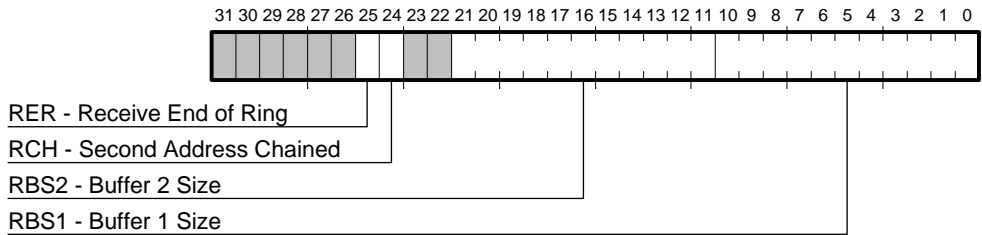

LJ-04698.WMF

Descriptor Lists and Data Buffers

Table 4–2 describes the RDES1 bit fields.

Table 4–2 RDES1 Bit Fields Description

Field	Description
25	RER—Receive End of Ring When set, indicates that the descriptor list reached its final descriptor. The 21143 returns to the base address of the list (Section 3.2.2.7), creating a descriptor ring.
24	RCH—Second Address Chained When set, indicates that the second address in the descriptor is the next descriptor address, rather than the second buffer address. RDES1<25> takes precedence over RDES1<24>.
21:11	RBS2—Buffer 2 Size Indicates the size, in bytes, of the second data buffer. If this field is 0, the 21143 ignores this buffer and fetches the next descriptor. The buffer size must be a multiple of 4. This field is not valid if RDES1<24> is set.
10:0	RBS1—Buffer 1 Size Indicates the size, in bytes, of the first data buffer. If this field is 0, the 21143 ignores this buffer and uses buffer 2. The buffer size must be a multiple of 4.

4.2.1.3 Receive Descriptor 2 (RDES2)

Figure 4–5 shows the RDES2 bit field.

Figure 4–5 RDES2 Bit Field

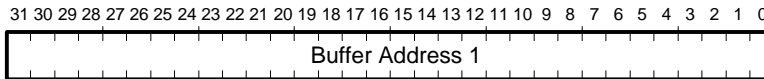

LJ-04702.WMF

Table 4–3 describes the RDES2 bit field.

Table 4–3 RDES2 Bit Field Description

Field	Description
31:0	Buffer Address 1 Indicates the physical address of buffer 1. The buffer must be longword aligned (RDES2<1:0> = 00).

4.2.1.4 Receive Descriptor 3 (RDES3)

Figure 4–6 shows the RDES3 bit field.

Figure 4–6 RDES3 Bit Field

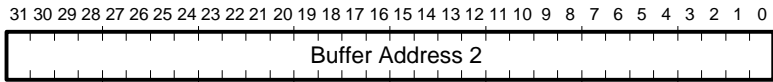

LJ-04703.WMF

Table 4–4 describes the RDES3 bit field.

Table 4–4 RDES3 Bit Field Description

Field	Description
31:0	Buffer Address 2 Indicates the physical address of buffer 2. The buffer must be longword aligned (RDES3<1:0> = 00).

Descriptor Lists and Data Buffers

4.2.1.5 Receive Descriptor Status Validity

Table 4–5 lists the validity of the receive descriptor status bits in relation to the reception completion status.

Table 4–5 Receive Descriptor Status Validity

Reception Status	Receive Status Report							
	RF	CS	FT	FF	DB	CE	RE	(ES, DE, DT, FS, LS, FL)
Collision after 512 bits	0	1	V	V	NV	NV	V	V
Runt frame	1	0	V	NV	V	NV	V	V
Runt frame less than 14 bytes	1	0	NV	NV	V	NV	V	V
Watchdog timeout	0	V	V	V	V	NV	V	V

List of table abbreviations

RF—Runt frame (RDES0<11>)	DE—Descriptor error (RDES0<14>)
CS—Collision seen (RDES0<6>)	DT—Data type (RDES0<13:12>)
FT—Frame type (RDES0<5>)	FS—First descriptor (RDES0<9>)
FF—Filtering fail (RDES0<30>)	LS—Last descriptor (RDES0<8>)
DB—Dribbling bit (RDES0<2>)	FL—Frame length (RDES0<30:16>)
CE—CRC error (RDES0<1>)	V—Valid
RE—Report on MII error (RDES0<3>)	NV—Not valid
ES—Error summary (RDES0<15>)	

4.2.2 Transmit Descriptors

Figure 4–7 shows the transmit descriptor format.

Note: Descriptor addresses must be longword aligned.

Providing two buffers, two byte-count buffers, and two address pointers in each descriptor enables the adapter port to be compatible with various types of memory-management schemes.

Figure 4-7 Transmit Descriptor Format

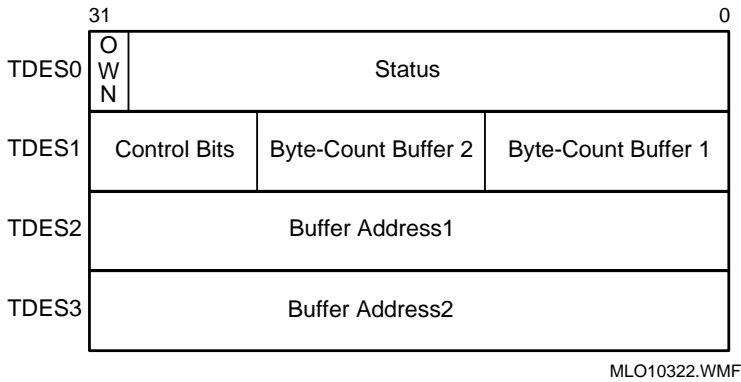

4.2.2.1 Transmit Descriptor 0 (TDES0)

TDES0 contains transmitted frame status and descriptor ownership information. Figure 4-8 shows the TDES0 bit fields.

Figure 4-8 TDES0 Bit Fields

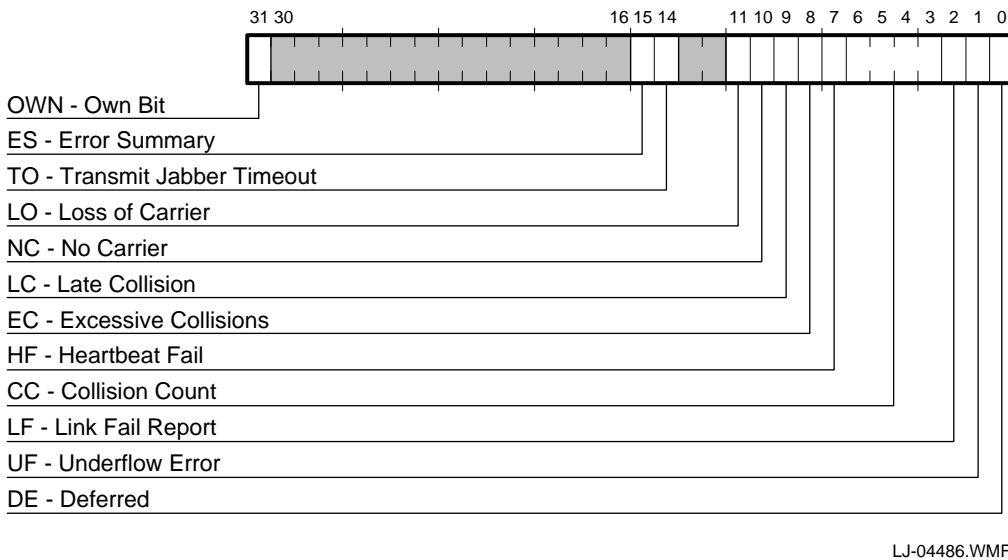

Descriptor Lists and Data Buffers

Table 4–6 describes the TDES0 bit fields.

Table 4–6 TDES0 Bit Fields Description

(Sheet 1 of 2)

Field	Description
31	OWN—Own Bit When set, indicates that the descriptor is owned by the 21143. When cleared, indicates that the descriptor is owned by the host. The 21143 clears this bit either when it completes the frame transmission or when the buffers allocated in the descriptor are empty. The ownership bit of the first descriptor of the frame should be set after all subsequent descriptors belonging to the same frame have been set. This avoids a possible race condition between the 21143 fetching a descriptor and the driver setting an ownership bit.
15	ES—Error Summary Indicates the logical OR of the following bits: TDES0<1>—Underflow error TDES0<8>—Excessive collisions TDES0<9>—Late collision TDES0<10>—No carrier TDES0<11>—Loss of carrier TDES0<14>—Transmit jabber timeout summary
14	TO—Transmit Jabber Timeout When set, indicates that the transmit jabber timer timed out and that the 21143 transmitter was still active. The transmit jabber timeout interrupt CSR5<3> is set. The transmission process is <i>aborted</i> and placed in the STOPPED state. When TDES0<14> is set, any heartbeat fail indication (TDES0<7>) is not valid.
11	LO—Loss of Carrier When set, indicates loss of carrier during transmission. Not valid in internal loopback mode (CSR6<11:10>=01).
10	NC—No Carrier When set, indicates that the carrier signal from the transceiver was not present during transmission. Not valid in internal loopback mode (CSR6<11:10>=01).
9	LC—Late Collision When set, indicates that the frame transmission was aborted due to collision occurring after the collision window of 64 bytes. Not valid if underflow error (TDES0<1>) is set.
8	EC—Excessive Collisions When set, indicates that the transmission was aborted after 16 successive collisions while attempting to transmit the current frame.

Table 4–6 TDES0 Bit Fields Description

(Sheet 2 of 2)

Field	Description
7	<p>HF—Heartbeat Fail</p> <p>This bit is effective only in 10BASE-T/AUI operating mode. When set, this bit indicates a heartbeat collision check failure (the transceiver failed to return a collision pulse as a check after the transmission). For transceivers that do not support heartbeat collision check, heartbeat fail is set but is not valid.</p> <p>This bit is not valid if underflow error (TDES0<1>) is set.</p> <p>On the second transmission attempt, after the first transmission was aborted due to a collision, the 21143 does not check heartbeat fail (TDES0<7>) and is reset.</p>
6:3	<p>CC—Collision Count</p> <p>This 4-bit counter indicates the number of collisions that occurred before the frame was transmitted.</p> <p>Not valid when the excessive collisions bit (TDES0<8>) is also set.</p>
2	<p>LF—Link Fail Report</p> <p>When set, indicates that the link test failed before the frame was transmitted.</p> <p>This bit is only valid in 10BASE-T mode (CSR6<18> = 0, CSR13<3> = 0) and 100-Mb/s SYM mode (CSR6<18> = 1, CSR6<23> = 1).</p>
1	<p>UF—Underflow Error</p> <p>When set, indicates that the transmitter aborted the message because data arrived late from memory. Underflow error indicates that the 21143 encountered an empty transmit FIFO while transmitting a frame. The transmission process enters the suspended state and sets both transmit underflow (CSR5<5>) and transmit interrupt (CSR5<0>).</p>
0	<p>DE—Deferred</p> <p>When set, indicates that the 21143 had to defer while ready to transmit a frame because the carrier was asserted.</p>

Descriptor Lists and Data Buffers

4.2.2.2 Transmit Descriptor 1 (TDES1)

Figure 4–9 shows the TDES1 bit fields.

Figure 4–9 TDES1 Bit Fields

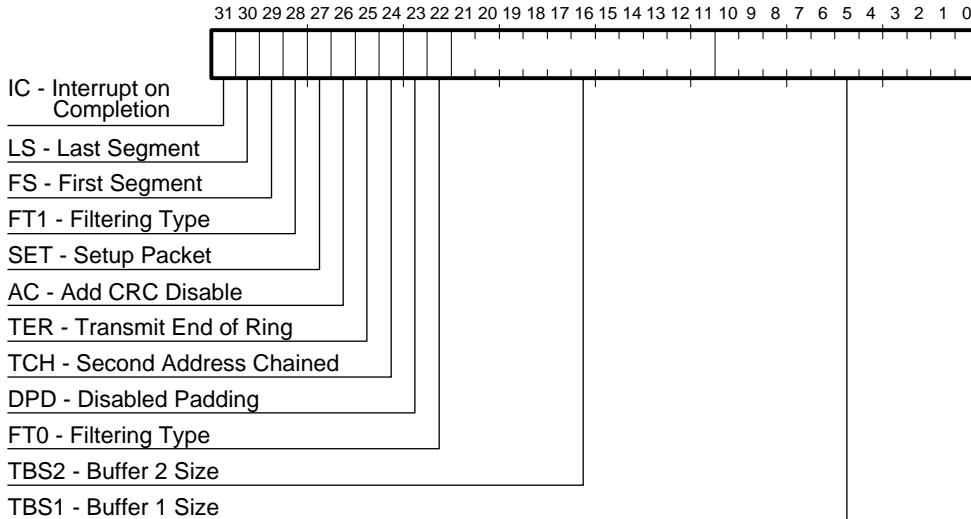

LJ-04699.WMF

Table 4–7 describes the TDES1 bit fields.

Table 4–7 TDES1 Bit Fields Description

(Sheet 1 of 2)

Field	Description
31	IC—Interrupt on Completion When set, the 21143 sets transmit interrupt (CSR5<0>) after the present frame has been transmitted. It is valid only when last segment (TDES1<30>) is set or when it is a setup packet.
30	LS—Last Segment When set, indicates that the buffer contains the last segment of a frame.
29	FS—First Segment When set, indicates that the buffer contains the first segment of a frame.

Table 4–7 TDES1 Bit Fields Description

(Sheet 2 of 2)

Field	Description
28	<p>FT1—Filtering Type</p> <p>This bit is valid only when setup packet (TDES1<27>) is set. Table 4–8 lists the filtering types.</p>
27	<p>SET—Setup Packet</p> <p>When set, indicates that the current descriptor is a setup frame descriptor (Section 4.2.3).</p>
26	<p>AC—Add CRC Disable</p> <p>When set, the 21143 does not append the cyclic redundancy check (CRC) to the end of the transmitted frame. This field is valid only when first segment (TDES1<29>) is set.</p>
25	<p>TER—Transmit End of Ring</p> <p>When set, indicates that the descriptor pointer has reached its final descriptor. The 21143 returns to the root address of the list (Section 3.2.2.7). This creates a descriptor ring.</p>
24	<p>TCH—Second Address Chained</p> <p>When set, indicates that the second address in the descriptor is the next descriptor address, rather than the second buffer address.</p> <p>Transmit end of ring (TDES1<25>) takes precedence over second address chained (TDES1<24>).</p>
23	<p>DPD—Disabled Padding</p> <p>When set, the 21143 does not automatically add a padding field, to a packet shorter than 64 bytes.</p> <p>When reset, the 21143 automatically adds a padding field and also a CRC field to a packet shorter than 64 bytes. The CRC field is added despite the state of the add CRC disable (TDES1<26>) flag.</p>
22	<p>FT0—Filtering Type</p> <p>This bit is valid only when setup packet (TDES1<27>) is set. Table 4–8 lists the filtering types.</p>
21:11	<p>TBS2—Buffer 2 Size</p> <p>Indicates the size, in bytes, of the second data buffer. If this field is 0, the 21143 ignores this buffer and fetches the next descriptor.</p> <p>This field is not valid if second address chained (TDES1<24>) is set.</p>
10:0	<p>TBS1—Buffer 1 Size</p> <p>Indicates the size, in bytes, of the first data buffer. If this field is 0, the 21143 ignores this buffer and uses buffer 2.</p>

Descriptor Lists and Data Buffers

Table 4–8 lists the filtering types. Table 3–75 provides additional information on filtering.

Table 4–8 Filtering Type

FT1	FT0	Description
0	0	Perfect Filtering The 21143 interprets the descriptor buffer as a setup perfect table of 16 addresses, and sets the 21143 filtering mode to perfect filtering.
0	1	Hash Filtering The 21143 interprets the descriptor buffer as a setup hash table of 512-bit-plus-one perfect address. If an incoming receive packet destination address is a multicast address, the 21143 executes an imperfect address filtering compared with the hash table. However, if the incoming receive packet destination address is a physical address, the 21143 executes a perfect filtering compared with the perfect address.
1	0	Inverse Filtering The 21143 interprets the descriptor buffer as a setup perfect table of 16 addresses and sets the 21143 filtering mode to inverse filtering. The 21143 receives the incoming frames with destination addresses not matching the perfect addresses and rejects the frames with destination addresses matching one of the perfect addresses.
1	1	Hash-Only Filtering The 21143 interprets the descriptor buffer as a setup 512-bit hash table. If an incoming receive packet destination address is multicast or physical, the 21143 executes an imperfect address filtering against the hash table.

4.2.2.3 Transmit Descriptor 2 (TDES2)

Figure 4–10 shows the TDES2 bit field.

Figure 4–10 TDES2 Bit Field

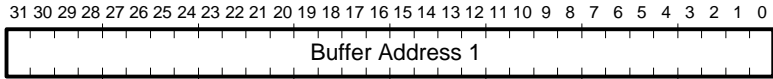

LJ-04702.WMF

Table 4–9 describes the TDES2 bit field.

Table 4–9 TDES2 Bit Field Description

Field	Description
31:0	Buffer Address 1 Physical address of buffer 1. There are no limitations on the buffer address alignment.

4.2.2.4 Transmit Descriptor 3 (TDES3)

Figure 4–11 shows the TDES3 bit field.

Figure 4–11 TDES3 Bit Field

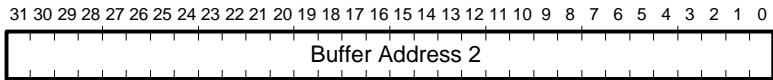

LJ-04703.WMF

Table 4–10 describes the TDES3 bit field.

Table 4–10 TDES3 Bit Field Description

Field	Description
31:0	Buffer Address 2 Physical address of buffer 2. There are no limitations on the buffer address alignment.

Descriptor Lists and Data Buffers

4.2.2.5 Transmit Descriptor Status Validity

Table 4–11 lists the validity of the transmit descriptor status bits during transmission completion status.

Table 4–11 Transmit Descriptor Status Validity

Transmission Status	Transmit Status Report						
	LO	NC	LC	EC	HF	CC	(ES, TO, UF, DE)
Underflow	V	V	V	V	V	V	V
Excessive collisions	V	V	V	V	V	NV	V
Watchdog timeout	NV	V	NV	NV	NV	V	V
Internal loopback	NV	NV	V	V	NV	V	V

List of table abbreviations

LO—Loss of carrier (TDES0<11>)	ES—Error summary (TDES0<15>)
NC—No carrier (TDES0<10>)	TO—Transmit jabber timeout (TDES0<14>)
LC—Late collision (TDES0<9>)	UF—Underflow error (TDES0<1>)
EC—Excessive collisions (TDES0<8>)	DE—Deferred (TDES0<0>)
HF—Heartbeat fail (TDES0<7>)	V—Valid
CC—Collision count (TDES0<6:3>)	NV—Not valid

4.2.3 Setup Frame

A setup frame defines the 21143 Ethernet addresses that are used to filter all incoming frames. The setup frame is *never* transmitted on the Ethernet wire nor is it looped back to the receive list. When processing the setup frame, the receiver logic temporarily disengages from the Ethernet wire. The setup frame size must be *exactly* 192 bytes.

Note: The setup frame must be allocated in a single buffer that is longword aligned. First segment (TDES1<29>) and last segment (TDES1<30>) must both be 0.

When the setup frame load is completed, the 21143 closes the setup frame descriptor by clearing its ownership bit and by setting all other bits to 1.

4.2.3.1 First Setup Frame

A setup frame must be processed before the reception process is started, except when it operates in promiscuous filtering mode.

4.2.3.2 Subsequent Setup Frames

Subsequent setup frames may be queued to the 21143 despite the reception process state. To ensure correct setup frame processing, these packets may be queued at the beginning of the transmit descriptor's ring or following a descriptor with a zero-length buffer. For the descriptor with a zero-length buffer, it should contain the following information:

TDES0<31> = 1 (Adapter-owned descriptor)
TDES1<30> = 0 (Last segment bit 0)
TDES1<29> = 0 (First segment bit 0)
TDES1<21:11> = 0 (Transmit buffer 2 empty)
TDES1<10:0> = 0 (Transmit buffer 1 empty)

Setup packet (TDES1<27>) may also be set. If so, the address filtering bits (TDES1<22> and TDES1<28>) should be the same as in the previous packet. For setup frame processing, the transmission process must be running. The setup frame is processed after all preceding frames have been transmitted and the current frame reception, if any, is completed.

The setup frame does not affect the reception process state, but during setup frame processing, the 21143 is disengaged from the Ethernet wire.

4.2.3.3 Perfect Filtering Setup Frame Buffer

This section describes how the 21143 interprets a setup frame buffer in perfect filtering mode (CSR6<0> = 0).

The 21143 can store 16 destination addresses (full 48-bit Ethernet addresses). The 21143 compares the addresses of any incoming frame to these addresses, and also tests the status of the inverse filtering (CSR6<4>). It rejects addresses that:

- Do not match if inverse filtering (CSR6<4>) is reset.
- Match if inverse filtering is set.

The setup frame must *always* supply all 16 addresses. Any mix of physical and multicast addresses can be used. Unused addresses should duplicate one of the valid addresses.

Descriptor Lists and Data Buffers

Figure 4–12 shows the perfect filtering setup frame buffer format of the addresses.

Figure 4–12 Perfect Filtering Setup Frame Buffer Format

	31	16 15	0
<3:0>	XXXXXXXXXXXXXXXXXXXX	Physical Address 00 (Bytes <1:0>)	
<7:4>	XXXXXXXXXXXXXXXXXXXX	Physical Address 00 (Bytes <3:2>)	
<11:8>	XXXXXXXXXXXXXXXXXXXX	Physical Address 00 (Bytes <5:4>)	
	XXXXXXXXXXXXXXXXXXXX	Physical Address 01	
	XXXXXXXXXXXXXXXXXXXX	Physical Address 01	
	XXXXXXXXXXXXXXXXXXXX	Physical Address 01	
	XXXXXXXXXXXXXXXXXXXX	Physical Address 02	
	XXXXXXXXXXXXXXXXXXXX	Physical Address 02	
	XXXXXXXXXXXXXXXXXXXX	Physical Address 02	
		Physical Address 03 : :	
	XXXXXXXXXXXXXXXXXXXX	Physical Address 14	
	XXXXXXXXXXXXXXXXXXXX	Physical Address 14	
	XXXXXXXXXXXXXXXXXXXX	Physical Address 14	
<183:180>	XXXXXXXXXXXXXXXXXXXX	Physical Address 15 (Bytes <1:0>)	
<187:184>	XXXXXXXXXXXXXXXXXXXX	Physical Address 15 (Bytes <3:2>)	
<191:188>	XXXXXXXXXXXXXXXXXXXX	Physical Address 15 (Bytes <5:4>)	

XXXXXX = Don't care

LJ-04684.WMF

The low-order bit of the low-order bytes is the multicast bit of the address.

4.2.3.4 Imperfect Filtering Setup Frame Buffer

This section describes how the 21143 interprets a setup frame buffer in imperfect filtering mode ($CSR6\langle 0 \rangle$ is set). Figure 4–13 shows imperfect filtering.

Figure 4–13 Imperfect Filtering

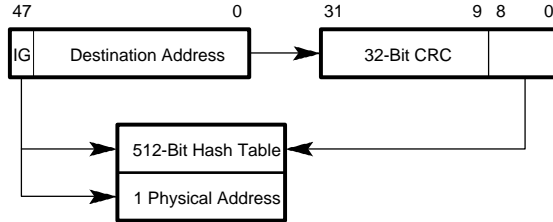

LJ-04726.WMF

The 21143 can store 512 bits serving as hash bucket heads, and one *physical* 48-bit Ethernet address. Incoming frames with multicast destination addresses are subjected to imperfect filtering. Frames with physical destination addresses are checked against the single physical address.

For any incoming frame with a multicast destination address, the 21143 applies the standard Ethernet cyclic redundancy check (CRC) function to the first 6 bytes containing the destination address, then it uses the most significant 9 bits of the result as a bit index into the table. If the indexed bit is set, the frame is accepted. If the bit is cleared, the frame is rejected. (Appendix C provides an example of a hash index for a given Ethernet address.)

This filtering mode is called imperfect because multicast frames not addressed to this station may slip through, but it still decreases the number of frames that the host can receive.

Figure 4–14 shows the format for the hash table and the physical address.

Descriptor Lists and Data Buffers

Figure 4–14 Imperfect Filtering Setup Frame Buffer Format

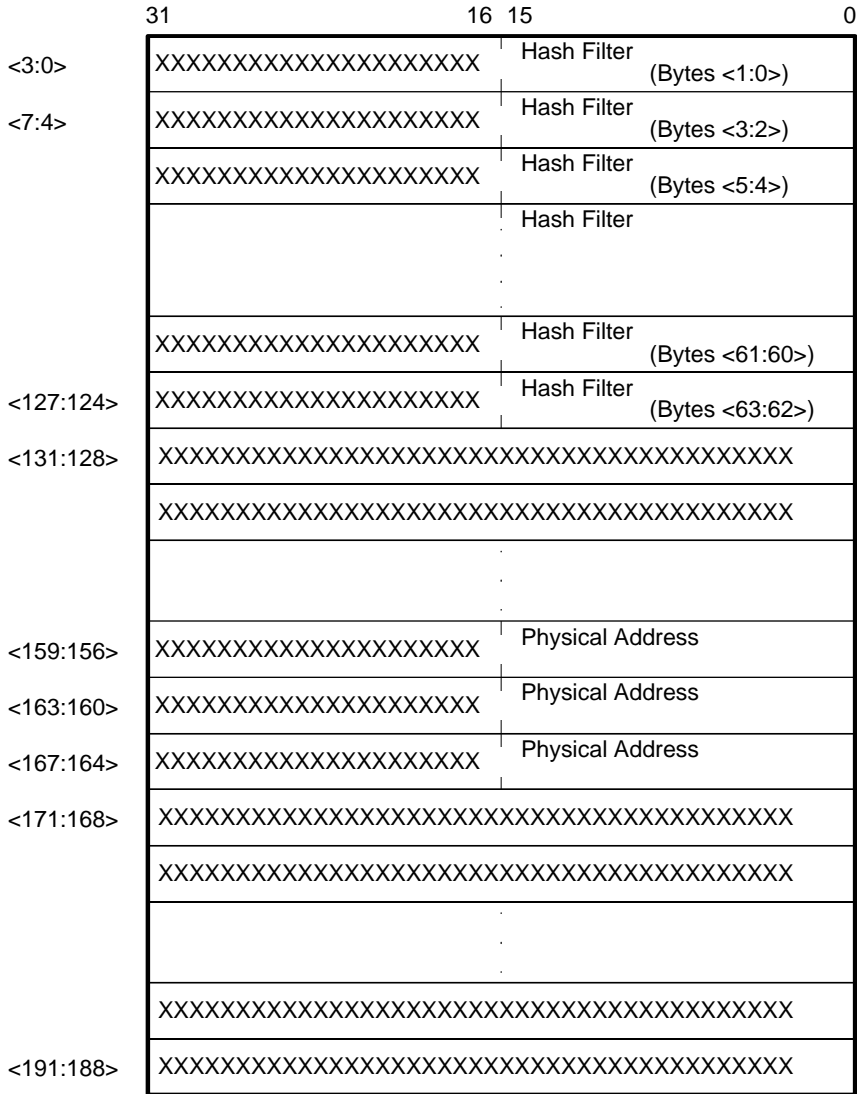

XXXXXX = Don't care

LJ-04685.WMF

Bits are sequentially numbered from right to left and down the hash table. For example, if the CRC (destination address) <8:0> = 33, the 21143 examines bit 1 in the third longword.

4.3 Functional Description

This section describes the reset commands, interrupt handling, and startup. It also describes the transmit and receive processes.

The functional operation of the 21143 is controlled by the driver interface located in the host communication area. The driver interface activity is controlled by control and status registers (CSRs), descriptor lists, and data buffers.

Descriptor lists and data buffers, collectively referred to as the host communication area, reside in host memory. These data structures process the actions and status related to buffer management. The 21143 transfers frame data to and from the receive and transmit buffers in host memory. Descriptors resident in the host memory point to these buffers.

4.3.1 Reset Commands

The following two commands are available to reset the 21143 hardware and software:

- Assert **rst_1**, to initiate a hardware reset.
- Assert CSR0<0>, to initiate a software reset.

For a proper hardware reset, both **pci_clk** and **xtal1** clocks should be active. Note that after a hardware reset, the mode is set to 10BASE-T/AUI. For a proper software reset, both **pci_clk** and the correct serial clock (for example, **mii_tclk** when in MII mode or **xtal1** when in either 10BASE-T or AUI mode) should be active. For both the hardware and software reset commands, the 21143 *aborts* all processing and starts the reset sequence. The 21143 initializes all internal states and registers.

Note: No internal states are retained, no descriptors are owned, and all the host-visible registers are set to the reset values. However, a software reset command has no effect on the configuration registers or on CSR6<18> port select.

The 21143 does not explicitly disown any owned descriptor; descriptor-owned bits can be left in a state indicating 21143 ownership. Section 4.2.1.1 and Section 4.2.2.1 provide a detailed description of own bits.

Functional Description

After either a hardware or software reset command, the first bus transaction to the 21143 should not be initiated for at least 50 PCI clock cycles. When the reset sequence completes, the 21143 can accept host commands. The receive and transmit processes are placed in the stopped state (Table 4–13 and Table 4–14). It is permissible to issue successive reset commands (hardware or software).

4.3.2 DMA Arbitration Scheme

The DMA arbitration scheme is used by the 21143 to grant precedence to the receive process instead of the transmit process ($CSR0<1>$). The technical expressions used in this table are described in the following list:

- *Txreq*—Specifies a DMA request for the transmit process to:
 - Fetch descriptor.
 - Close descriptor.
 - Process setup packet.
 - Transfer data from the host buffer to the transmit FIFO when there is sufficient space in the transmit FIFO for a full data burst.
- *Rxreq*—Specifies a DMA request for the receive process to:
 - Fetch descriptor.
 - Close descriptor.
 - Transfer data from the receive FIFO to the host buffer when the receive FIFO contains sufficient data for a full data burst or contains the end of the packet.
- *TxEN*—Specifies that the 21143 is currently transmitting.
- *RxF<thrx*—Specifies that the amount of free bytes left in the receive FIFO is less than an internal threshold.
- *TxF<thtx*—Specifies that the amount of bytes in the transmit FIFO is less than an internal threshold.

Table 4–12 lists a description of the arbitration scheme.

Table 4–12 Arbitration Scheme

Txreq	Rxreq	TxEN	RxF<thrx	TxF<thtx	Chosen Process
0	0	0	—	—	—
0	0	1	—	—	—
0	1	0	—	—	Receive process
0	1	1	—	—	Receive process
1	0	0	—	—	Transmit process
1	0	1	—	—	Transmit process
1	1	0	—	—	Receive process
1	1	1	0	0	Transmit process
1	1	1	0	1	Transmit process
1	1	1	1	0	Receive process
1	1	1	1	1	Transmit process ¹

¹The transmit process choice is true only when working in half-duplex mode. When working in full-duplex mode, a round-robin arbitration scheme will be applied.

In addition to the arbitration scheme listed in Table 4–12, two other factors must be considered:

- The transmit process obtains a window for one burst between two consecutive receive packets.
- The receive process obtains a window for one burst between two consecutive transmit packets.

4.3.3 Interrupts

Interrupts can be generated as a result of various events. CSR5 contains all the status bits that might cause an interrupt. CSR7 contains an enable bit for each of the events that can cause an interrupt. An event will cause an interrupt only if it is enabled in CSR7.

Functional Description

The interrupts are divided into two groups: the normal interrupts and the abnormal interrupts. Each of these groups has a summary bit in CSR5, indicating that one of the events under the group has caused an interrupt. The 21143 asserts the **int_1** pin when at least one of the interrupt summary bits is set.

The following list contains the events that belong to the *normal* interrupts group:

- CSR5<0>—Transmit interrupt
- CSR5<2>—Transmit buffer unavailable
- CSR5<6>—Receive interrupt
- CSR5<11>—General-purpose timer expired
- CSR5<14>—Early receive interrupt

The following list contains the events that belong to the *abnormal* interrupts group:

- CSR5<1>—Transmit process stopped
- CSR5<3>—Transmit jabber timeout
- CSR5<4>—Link pass or autonegotiation completed
- CSR5<5>—Transmit underflow
- CSR5<7>—Receive buffer unavailable
- CSR5<8>—Receive process stopped
- CSR5<9>—Receive watchdog timeout
- CSR5<10>—Early transmit interrupt
- CSR5<12>—Link fail
- CSR5<13>—Fatal bus error
- CSR5<26>—General-purpose port interrupt
- CSR5<27>—Link changed

Interrupt bits are cleared by writing a 1 to the bit position. When all enabled bits in one of the interrupt groups are cleared, the corresponding summary bit is cleared. If both summary bits are cleared, the 21143 deasserts the **int_1** pin.

Interrupts are not queued, and if the interrupting event recurs *before* the driver has responded to it, no additional interrupts are generated. For example, receive interrupt (CSR5<6>) indicates that one or more received frames were delivered to host memory. The driver must scan *all* descriptors, from the last recorded position to the first one owned by the 21143.

An interrupt is generated only *once* for simultaneous, multiple interrupting events. The driver must scan CSR5 for the interrupt cause or causes. The interrupt is not generated *again*, unless a new interrupting event occurs after the driver has cleared the appropriate CSR5 bits.

For example, transmit interrupt (CSR5<0>) and receive interrupt (CSR5<6>) are set simultaneously. The host acknowledges the interrupt, and the driver begins executing by reading CSR5. Next, receive buffer unavailable (CSR5<7>) is set. The driver writes back its copy of CSR5, clearing transmit interrupt and receive interrupt. The interrupt line is deasserted for at least one cycle and then asserted again with receive buffer unavailable.

4.3.3.1 Receive and Transmit Interrupt Mitigation

The interrupt mitigation timers and counters allow the software driver to reduce the number of transmit interrupts (CSR5<0>) and receive interrupts (CSR5<6>).¹ This lowers CPU utilization for servicing a large number of interrupts.

The adapter has two counters for counting the received and transmitted packets, and two associated timers. The mitigation mechanism is similar for both receive and transmit interrupts.

Both counters and timers are programmed by writing to CSR11. Programming the counter to zero disables the counter effect on the interrupt mitigation mechanism. Programming the timer to zero disables the timer effect on the interrupt mitigation mechanism.

The counter defines the maximum number of received or transmit interrupts that can be pending before an interrupt is generated. The timer defines the maximum delay an interrupt can be pending before the interrupt is generated.

The timer and counter combination allows for the batching of several packets into a single interrupt with a limit for how long it can be pending. This single interrupt prevents throughput from being impeded in heavy traffic, while the time limit prevents resources from being held for too long in low traffic.

In interrupt mitigation mode, instead of immediately generating a receive or transmit interrupt, the adapter decrements the associated interrupt counter and starts the associated timer if it is not already started. The pending interrupt(s) is (are) generated when either the counter or the timer expires. Both counter and timer are then reloaded.

When the receive or the transmit process moves to the suspended or stopped state, any pending interrupt(s) are immediately generated.

¹This feature is only supported in the 21143-PD and the 21143-TD.

Functional Description

This mechanism allows for reducing the number of interrupts without turning to the classic interrupt mode or polling mode where the CPU spends cycles on polling the interrupt status regardless of the traffic. This mechanism is also more efficient than the fixed interrupt rate interrupt scheme that generates the same rate of interrupts regardless of the traffic.

4.3.4 Initialization Procedure

The following sequence of checks and commands must be performed by the driver to prepare the 21143 for operation:

1. Wait 50 PCI clock cycles for the 21143 to complete its reset sequence.
2. Update configuration registers (Section 3.1):
 - a. Read the configuration ID and revision registers to identify the 21143 and its revision.
 - b. Write the configuration interrupt register (if interrupt mapping is necessary).
 - c. Write the configuration base address registers to map the 21143 I/O or memory address space into the appropriate processor address space.
 - d. Write the configuration command register.
 - e. Write the configuration latency counter to match the system latency guidelines.
3. Write CSR0 to set global host bus operating parameters (Section 3.2.2.1).
4. Write CSR7 to mask unnecessary (depending on the particular application) interrupt causes.
5. The driver must create the transmit and receive descriptor lists. Then, it writes to both CSR3 and CSR4, providing the 21143 with the starting address of each list (Section 3.2.2.7). The first descriptor on the transmit list may contain a setup frame (Section 4.2.3).

Caution: If address filtering (either perfect or imperfect) is desired, the receive process should only be started after the setup frame has been processed (Section 4.2.3).

6. When in either 10BASE-T or AUI mode, change the default settings of the jabber timers and also the initial SIA settings by writing to CSR13 (Section 3.2.2.16), CSR14 (Section 3.2.2.17), and CSR15 (Section 3.2.2.18).
7. Write CSR6 (Section 3.2.2.9) to set global serial parameters and to start both the receive and transmit processes. The receive and transmit processes enter the running state and attempt to acquire descriptors from the respective descriptor

lists. Then the receive and transmit processes begin processing incoming and outgoing frames. The receive and transmit processes are independent of each other and can be started and stopped separately.

4.3.5 Receive Process

While in the running state, the receive process polls the receive descriptor list, attempting to acquire free descriptors. Incoming frames are processed and placed in acquired descriptors' data buffers. Status information is written to RDES0 of the last receive descriptor of the frame.

4.3.5.1 Descriptor Acquisition

The 21143 always attempts to acquire an extra descriptor in anticipation of incoming frames. Descriptor acquisition is attempted if any of the following conditions are satisfied:

- When start/stop receive (CSR6<1>) sets immediately after being placed in the running state.
- When the 21143 begins writing frame data to a data buffer pointed to by the current descriptor, and the buffer ends before the frame ends.
- When the 21143 completes the reception of a frame, and the current receive descriptor has been closed.
- When the receive process is suspended because of a host-owned buffer (RDES0<31>=0), and a new frame is received.
- When receive poll demand is issued (Section 3.2.2.5).

4.3.5.2 Frame Processing

As incoming frames arrive, the 21143 recovers the incoming data and clock pulses, and then sends them to the receive engine. The receive engine strips the preamble bits and stores the frame data in the receive FIFO. Concurrently, the receive section performs address filtering depending on the results of inverse filtering (CSR6<6>), hash/perfect receive filtering mode (CSR6<0>), and hash-only receive filtering mode (CSR6<2>), and also its internal filtering table. If the frame fails the address filtering, it is ignored and purged from the FIFO. Frames that are shorter than 64 bytes, because of collision or premature termination, are also ignored and purged from the FIFO (unless pass bad frames bit CSR6<3> is set).

Functional Description

After 64 bytes have been received, the 21143 requests the PCI bus to begin transferring the frame data to the buffer pointed to by the current descriptor. While waiting for the PCI bus, the 21143 continues to receive and store the data in the FIFO. After receiving the PCI bus, the 21143 sets first descriptor (RDES0<9>), to delimit the frame. Then, the descriptors are released when the OWN (RDES0<31>) bit is reset to 0, either as the data buffers fill up or as the last segment of a frame is transferred to a buffer. If a frame is contained in a single descriptor, both last descriptor (RDES0<8>) and first descriptor (RDES0<9>) are set.

The 21143 fetches the next descriptor, sets last descriptor (RDES0<8>), and releases the RDES0 status bits in the last frame descriptor. Then the 21143 sets receive interrupt (CSR5<6>). The same process repeats unless the 21143 encounters a descriptor flagged as being owned by the host. If this occurs, the receive process sets receive buffer unavailable (CSR5<7>) and then enters the suspended state. The position in the receive list is retained.

4.3.5.3 Receive Process Suspended

If a receive frame arrives while the receive process is suspended, the 21143 refetches the current descriptor in host memory. If the descriptor is now owned by the 21143, the receive process reenters the running state and starts the frame reception. If the descriptor is still owned by the host, the 21143 discards the current frame in the receive FIFO and increments the missed frames counter (CSR8<15:0>). If more than one frame is stored in the receive FIFO, the process repeats.

4.3.5.4 Receive Process State Transitions

Table 4–13 lists the receive process state transitions and the resulting actions.

Table 4–13 Receive Process State Transitions

From State	Event	To State	Action
Stopped	Start receive command.	Running	Receive polling begins from last list position or from the list head, if this is the first start receive command issued, or if the receive descriptor list address (CSR3) was modified by the driver.
Running	The 21143 attempts to acquire a descriptor owned by the host.	Suspended	Receive buffer unavailable (CSR5<7>) sets when the last acquired descriptor buffer is consumed. The position in the list is retained.
Running	Stop receive command.	Stopped	Receive process is stopped after the current frame, if any, is completely transferred to data buffers. Receive process stopped (CSR5<8>) sets. The position in the list is retained.
Running	Memory or host bus parity error encountered.	Running	The 21143 operation is stopped and fatal bus error (CSR5<13>) sets. The 21143 remains in the running state. A software reset must be issued to release the 21143.
Running	Reset command.	Stopped	Receive capability is cut off.
Suspended	Receive poll demand or incoming frame and available descriptor.	Running	Receive polling resumes from last list position.
Suspended	Stop receive command.	Stopped	Receive process stopped (CSR5<8>) sets.
Suspended	Reset command.	Stopped	None.

Functional Description

4.3.6 Transmit Process

While in the running state, the transmit process polls the transmit descriptor list for frames requiring transmission. After polling starts, it continues in either sequential descriptor ring order or chained order. When it completes frame transmission, status information is written into transmit descriptor 0 (TDES0). If the 21143 detects a descriptor flagged as owned by the host, or if an error condition occurs, the transmit process is suspended and both transmit buffer unavailable (CSR5<2>) and normal interrupt summary (CSR5<16>) are set.

Transmit interrupt (CSR5<0>) is set after completing transmission of a frame that has interrupt on completion (TDES1<31>) set in its last descriptor. When this occurs, the transmission process continues to run.

While in the running state, the transmit process can simultaneously acquire two frames. As the transmit process completes copying the first frame, it immediately polls the transmit descriptor list for the second frame. If the second frame is valid, the transmit process copies the frame before writing the status information of the first frame.

4.3.6.1 Frame Processing

Frames can be data-chained and span several buffers. Frames must be delimited by the first descriptor (TDES1<29>) and the last descriptor (TDES1<30>), respectively.

As the transmit process starts execution, the first descriptor must have TDES1<29> set. When this occurs, frame data transfers from the host buffer to the internal FIFO. Concurrently, if the current frame has the last descriptor TDES1<30> clear, the transmit process attempts to acquire the next descriptor. The transmit process expects this descriptor to have TDES1<29> clear. If TDES1<30> is clear, it indicates an intermediary buffer. If TDES1<30> is set, it indicates the last buffer of the frame.

After the last buffer of the frame has been transmitted, the 21143 writes back the final status information to the transmit descriptor 0 (TDES0) word of the descriptor that has the last segment set in transmit descriptor 1 TDES1<30>. At this time, if interrupt on completion (TDES1<31>) was set, the transmit interrupt (CSR5<0>) is set, the next descriptor is fetched, and the process repeats.

Actual frame transmission begins after the internal FIFO has reached either a programmable threshold CSR6<15:14> (Table 3–72), or a full frame is contained in the FIFO. There is also an option for store and forward mode CSR6<21>, (Table 3–71). Descriptors are released (OWN bit TDES0<31> clears) when the 21143 completes the packet transmission.

4.3.6.2 Transmit Polling Suspended

Transmit polling can be suspended by either of the following conditions:

- The 21143 detects a descriptor owned by the host (TDES0<31>=0). To resume, the driver must give descriptor ownership to the 21143 and then issue a poll demand command.
- A frame transmission is aborted when a locally induced error is detected. The appropriate transmit descriptor 0 (TDES0) bit is set.

If either of the previous two conditions occur, both abnormal interrupt summary (CSR5<15>) and transmit interrupt (CSR5<0>) are set, and the information is written to transmit descriptor 0, causing the suspension.

In both of the cases previously described, the position in the transmit list is retained. The retained position is that of the *descriptor following the last descriptor closed* (set to host ownership) by the 21143.

Note: The 21143 *does not* automatically poll the transmit descriptor list. The driver *must* explicitly issue a transmit poll demand command after rectifying the suspension cause, unless the transmit automatic polling (CSR0<19:17>) field is nonzero. In case of suspension as a result of underflow, the 21143 does not automatically poll the descriptors list even if CSR0<19:17> is nonzero.

Functional Description

4.3.6.3 Transmit Process State Transitions

Table 4–14 lists the transmit process state transitions and the resulting actions.

Table 4–14 Transmit Process State Transitions

(Sheet 1 of 2)

From State	Event	To State	Action
Stopped	Start transmit command.	Running	Transmit polling begins from one of the following positions: <ul style="list-style-type: none"> • The last list position. • The head of the list, if this is the first start command issued after CSR4 was initialized or modified.
Running	The 21143 attempts acquisition of a descriptor owned by the host.	Suspended	Transmit buffer unavailable. (CSR5<2>) is set.
Running	Frame transmission aborts because a locally induced underflow error (TDES0<1>) is detected (Section 4.2.2.1).	Suspended	The following bits are set: TDES0<1>—Underflow error CSR5<5>—Transmit underflow CSR5<15>—Abnormal interrupt summary
Running	Stop transmit command.	Stopped	Transmit process is stopped after the current frame, if any, is transmitted.
Running	Frame transmission aborts because a transmit jabber timeout (TDES0<14>) was detected (Section 4.2.2.1).	Stopped	The following bits are set: TDES0<14>— Transmit jabber timeout CSR5<1>—Transmit process stopped CSR5<3>—Transmit jabber timeout CSR5<15>—Abnormal interrupt summary
Running	Parity error detected by memory or host bus.	Running	Transmission is cut off and fatal bus error (CSR5<13>) is set. The 21143 remains in the running state. If a software reset occurs, normal operation continues.

Table 4–14 Transmit Process State Transitions

(Sheet 2 of 2)

From State	Event	To State	Action
Running	Reset command.	Stopped	Transmission is cut off. If CSR4 was not changed, the position in the list is retained. If CSR4 was changed, the next descriptor address is fetched from the header list (CSR4) when the poll demand command is issued. Transmit process stopped (CSR5<1>) is set.
Suspended	Transmit poll demand command issued.	Running	Transmit polling resumes from the last list position.
Suspended	Stop transmit command.	Stopped	Transmit process stopped (CSR5<1>) is set.
Suspended	Reset command.	Stopped	None.

4.3.7 Card Information Structure

The Card Information Structure (CIS), also known as tuples, is used in CardBus applications to store card information. This information is a structure of bytes used by the system software.

The 21143 supports two ways of storing the CIS data:

- External flash ROM
- Serial ROM¹

Storing the CIS data in the serial ROM eliminates the need for an external flash ROM and latches in CardBus applications.

The CIS pointer register is located in the PCI configuration space (CCIS). Its format is defined in the CardBus specification.

For more information about how to set the CIS pointer, see Appendix C of the *DIGITAL Semiconductor 21143 Serial ROM Format*.

¹Only the 21143–PD and the 21143–TD support storage of the CIS data in the serial ROM.

Host Bus Operation

This chapter describes the commands and operations of read and write cycles for a bus slave and a bus master. It also explains the initiation of termination cycles by the bus master or bus slave.

5.1 Overview

The peripheral component interconnect (PCI) is the physical interconnection used between highly integrated peripheral controller components and the host system. The 21143 uses the PCI bus to communicate with the host CPU and memory.

The 21143 is directly compatible with revision 2.0 and revision 2.1 of the *PCI Local Bus Specification*. The 21143 supports a subset of the PCI-bus cycles (transactions). When communicating with the host, the 21143 operates as a bus slave; when communicating with the memory, as a bus master.

All signals are sampled on the rising edge of the clock. Each signal has a setup and hold aperture with respect to the rising clock edge. Refer to the *DIGITAL Semiconductor 21143 PCI/CardBus 10/100-Mb/s Ethernet LAN Controller Data Sheet* for detailed timing information. Table 5–1 lists the codes for bus commands.

Note: The term **clock cycle**, as used in this chapter, refers to the PCI bus clock period specification.

Bus Commands

5.2 Bus Commands

Table 5–1 lists the bus commands.

Table 5–1 Bus Commands

c_be_l<3:0>	Command	Type of Support
0000	Interrupt acknowledge	Not supported
0001	Special cycle	Not supported
0010	I/O read	Supported as target
0011	I/O write	Supported as target
0100	Reserved	—
0101	Reserved	—
0110	Memory read	Supported as master and target
0111	Memory write	Supported as master and target
1000	Reserved	—
1001	Reserved	—
1010	Configuration read	Supported as target
1011	Configuration write	Supported as target
1100	Memory read multiple	Supported as master and target ¹
1101	Dual-address cycle	Not supported
1110	Memory read line	Supported as master and target ¹
1111	Memory write and invalidate	Supported as master and target ¹

¹Master support for this command is controlled by CSR0.

5.3 Bus Slave Operation

All host accesses to CSRs and configuration registers in the 21143 are executed with the 21143 acting as the slave. The bus slave can perform the following operations:

- I/O read
- I/O write
- Configuration read

- Configuration write
- Memory read
- Memory write

Other bus slave operations include memory write and invalidate, memory read line, and memory read multiple.

Note: The 21143 does not support the following bus transactions:

Interrupt acknowledge
Special cycle
Dual-address cycle

If the 21143 is targeted for a burst I/O or memory operation, it responds with a retry on the second data transaction.

5.3.1 Slave Read Cycle (I/O or Memory Target)

Figure 5–1 shows a typical slave read cycle. The 21143 I/O read cycle is executed as follows:

1. The host initiates the slave read cycle by asserting the **frame_1** signal, driving the address on the **ad** lines and driving the bus command (slave read operation) on the **c_be_1** lines.
2. The 21143 samples the address and the bus command on the next clock edge.
3. The host deasserts **frame_1** signal and asserts **irdy_1** signal.
4. The 21143 asserts **devsel_1**, and, at the next cycle, drives the data on the **ad** lines.
5. The read transaction completes when both **irdy_1** and **trdy_1** are asserted by the host and the 21143, respectively, on the same clock edge.

The 21143 assumes that **c_be_1** lines are 0000 (longword access).

If the **c_be_1** lines are 1111, the **ad** bus read is 00000000H with correct parity.

6. The host and the 21143 terminates the cycle by deasserting **irdy_1** and **trdy_1**, respectively.

Bus Slave Operation

Figure 5–1 Slave Read Cycle

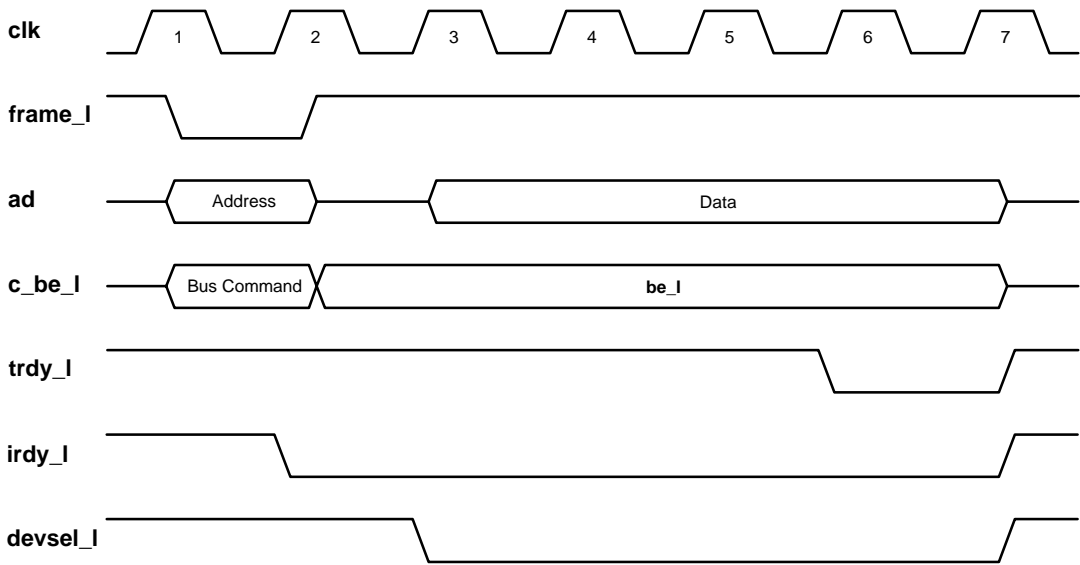

LJ-04741.WMF

5.3.2 Slave Write Cycle (I/O or Memory Target)

Figure 5–2 shows a typical slave write cycle. The 21143 slave write cycle is executed as follows:

1. The host initiates the slave write cycle by asserting the **frame_I** signal, driving both the address on the **ad** lines and the bus command (slave write operation) on the **c_be_I** lines.
2. The 21143 samples the address and the bus command on the next clock edge.
3. The host deasserts **frame_I** and drives the data on the **ad** lines along with **irdy_I**.
4. The 21143 samples the data, and also asserts both **devsel_I** and **trdy_I**.
5. The host and the 21143 complete the write transaction by asserting both **irdy_I** and **trdy_I**, respectively, on the same clock edge.

The 21143 assumes that **c_be_I** lines are 0000 (longword access).

If the **c_be_I** lines are 1111, the write transaction completes normally on the bus, but the write transaction to the CSR is not executed.

6. The host and the 21143 terminate the cycle by deasserting **irdy_I** and **trdy_I**, respectively.

Figure 5–2 Slave Write Cycle

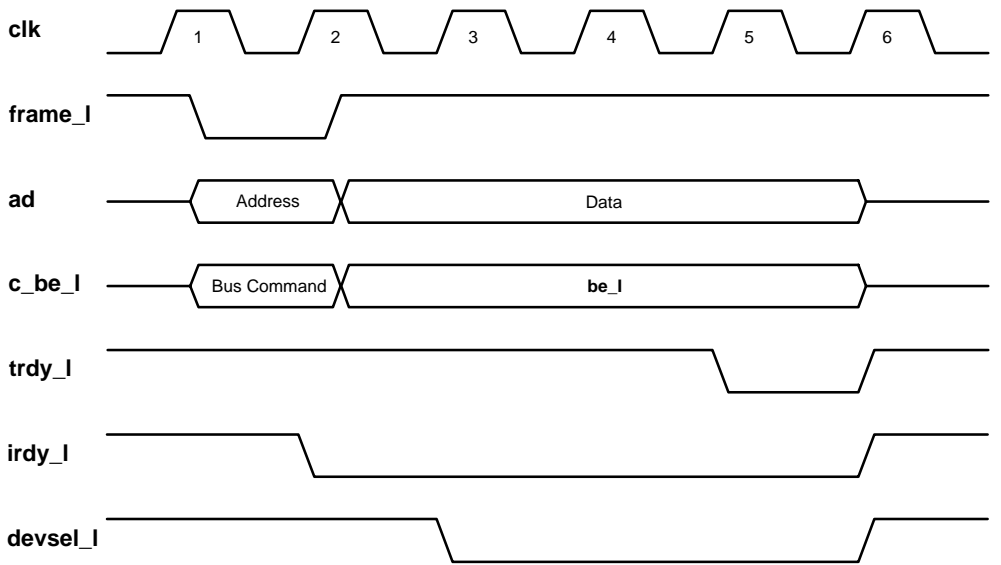

LJ-04742.WMF

5.3.3 Configuration Read and Write Cycles

The 21143 provides a way for software to analyze and configure the system before defining any address assignments or mapping. The 21143 provides 256 bytes of configuration registers. Section 3.1 describes these registers.

Note: Configuration space accesses provide support for **c_be_l** lines.

Figure 5–3 shows a configuration read cycle. The host selects the 21143 by asserting **idsel**. The 21143 responds by asserting **devsel_l**. The remainder of the read cycle is similar to the slave read cycle (Section 5.3.1).

Bus Master Operation

Figure 5–3 Configuration Read Cycle

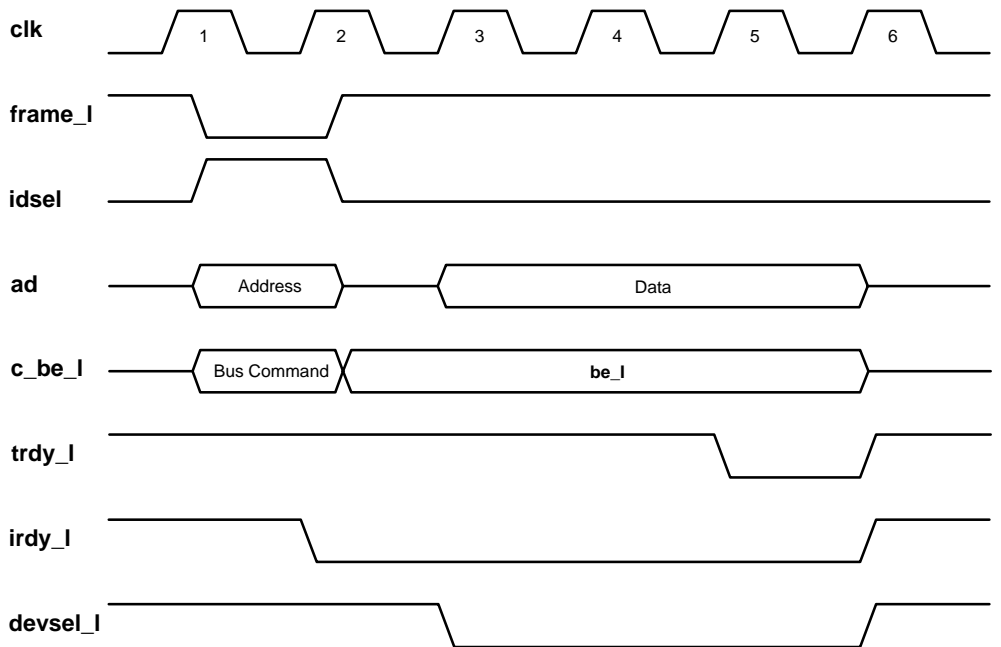

LJ-04743.WMF

5.4 Bus Master Operation

All memory accesses are completed with the 21143 as the master on the PCI bus. The bus master can perform the following operations:

- Bus arbitration
- Memory read cycle
- Memory write cycle
- Termination cycles

5.4.1 Bus Arbitration

The 21143 uses the PCI central arbitration mechanism with its unique request (**req_1**) and grant (**gnt_1**) signals. Figure 5–4 shows the bus arbitration mechanism. The 21143 bus arbitration is executed as follows:

1. The 21143 requests the bus by asserting **req_1**.
2. The arbiter, in response, asserts **gnt_1** (**gnt_1** can be deasserted on any clock).
3. The 21143 ensures that its **gnt_1** is asserted on the clock edge that it wants to drive **frame_1**. (If **gnt_1** is deasserted, the 21143 does not proceed.)
4. The 21143 deasserts **req_1** on the cycle that it asserts **frame_1**.

Figure 5–4 Bus Arbitration



LJ-04740.WMF

The 21143 uses **gnt_1** according to the following rules:

- If **gnt_1** is deasserted together with the assertion of **frame_1**, the 21143 continues its bus transaction.
- If **gnt_1** is asserted while **frame_1** remains deasserted, the arbiter can deassert **gnt_1** at any time. The 21143 does not assert **frame_1** until it is granted again.

Bus Master Operation

5.4.2 Memory Read Cycle

The memory read cycle is executed when the 21143 performs one of the following operations:

- Memory read
- Memory read multiple
- Memory read line

The 21143 chooses one of these commands for a memory read cycle according to the conditions described in the read line enable (CSR0<23>) bit and the read multiple enable (CSR0<21>) bit descriptions.

The memory read cycle is executed as follows:

1. The 21143 initiates the memory read cycle by asserting **frame_1**. It also drives the address on the **ad** lines and the appropriate bus command (memory read, memory read multiple, or memory read line) on the **c_be_1** lines.
2. The memory controller samples the address and the bus command on the next clock edge.
3. The 21143 asserts **irdy_1** until the end of the read transaction.
4. During the data transfer cycles, **c_be_1** indicates which byte lines are involved in each cycle. The 21143 drives 0000 on the **c_be_1** lines (longword access).
5. The memory controller drives the data on the **ad** lines and asserts **trdy_1**.
6. The 21143 samples the data on each rising clock edge when both **irdy_1** and **trdy_1** are asserted.
7. The previous two steps can be repeated a number of times.
8. The cycle is terminated when **frame_1** is deasserted by the 21143.
9. Signal **irdy_1** is deasserted by the 21143 and **trdy_1** is deasserted by the memory controller.

Figure 5–5 shows the memory read cycle.

Figure 5–5 Memory Read Cycle

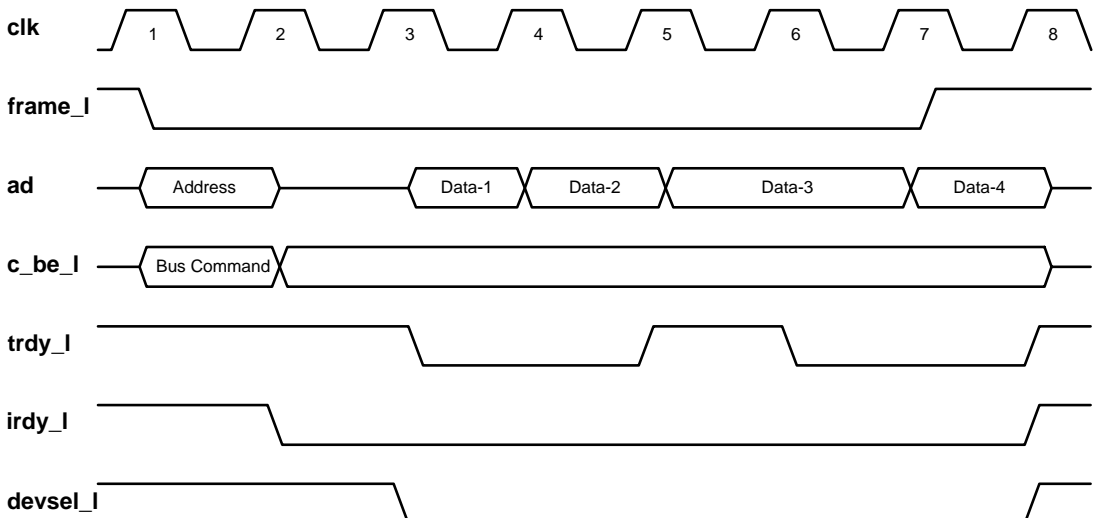

LJ-04727.WMF

5.4.3 Memory Write Cycle

The memory write cycle is executed when the 21143 performs one of the following operations:

- Memory write
- Memory write and invalidate

The 21143 chooses one of these commands for a memory write cycle according to the conditions described in the memory write and invalidate enable (CSR0<24>) bit description.

The memory write cycle is executed as follows:

1. The 21143 initiates the memory write cycle by asserting **frame_I**. It also drives the address on the **ad** lines and the appropriate bus command (memory write or memory write and invalidate) on the **c_be_I** lines.
2. The 21143 asserts **irdy_I** until the end of the transaction and drives the data on the **ad** lines.
3. The memory controller samples the address and the bus command on the next clock edge and asserts **devsel_I**.

Bus Master Operation

4. During the data transfer cycles, the **c_be_l** lines indicate which byte lines are involved in each cycle. The 21143 drives 0000 on the **c_be_l** lines (longword access).
5. The memory controller samples the data and asserts **trdy_l**. Each data cycle is completed on the rising clock edge when both **irdy_l** and **trdy_l** are asserted.
6. The previous two steps can be repeated a number of times.
7. The 21143 terminates the cycle by deasserting **frame_l**.
8. The 21143 deasserts **irdy_l** and the memory controller deasserts **trdy_l**.

Figure 5–6 shows the memory write cycle.

Figure 5–6 Memory Write Cycle

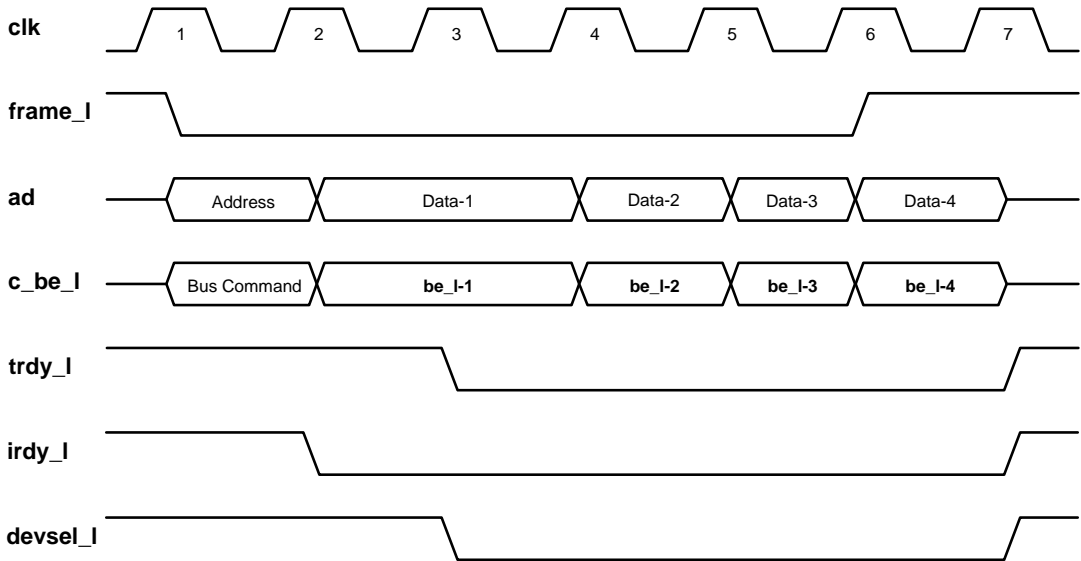

LJ-04728.WMF

5.5 Termination Cycles

Termination cycles can be initiated during either slave or master cycles.

5.5.1 Slave-Initiated Termination

A slave-initiated termination can occur when the 21143 operates as a slave device on the PCI bus. A slave can initiate the following types of terminations:

- Disconnect
- Retry

5.5.1.1 Disconnect Termination

The 21143 initiates disconnect termination in slave mode when it is accessed by the host with I/O or memory burst cycles. The 21143 asserts **stop_I** to request the host to terminate the transaction. After **stop_I** is asserted, it remains asserted until **frame_I** is deasserted.

Figure 5–7 shows the disconnected device (the host) releasing the bus. The host retries the last data transaction after acquiring the bus in a different arbitration.

Figure 5–7 21143-Initiated Disconnect Cycle

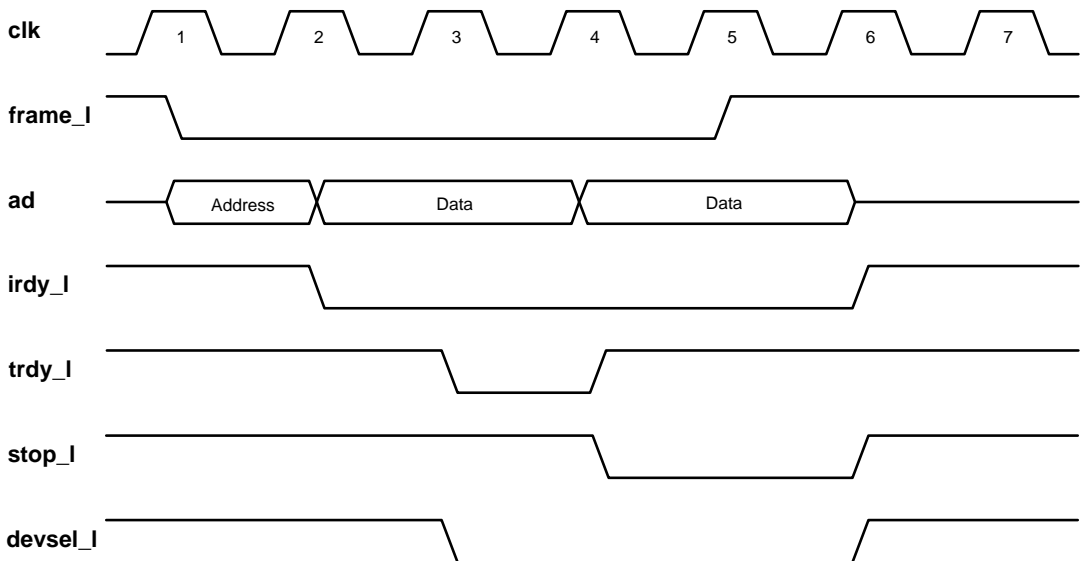

LJ-04729.WMF

Termination Cycles

5.5.1.2 Retry Termination

The 21143 initiates retry termination in slave mode when one of the following transactions occur:

- The 21143 registers CSR9 and CSR10 are accessed by the host, while the 21143 is still handling either a previous boot ROM or serial ROM access.
- The 21143 configuration registers CSID and CCIS are accessed by the host, before their contents are loaded from the serial ROM.

The 21143 does not assert **trdy_1** in response to these host accesses. It asserts **stop_1** requesting that the host terminate the transaction. Signal **stop_1** remains asserted until **irdy_1** is deasserted.

Figure 5–8 shows the retried device (the host) releasing the bus. The host retries the last data transaction after acquiring the bus in a different arbitration.

Figure 5–8 21143-Initiated Retry Cycle

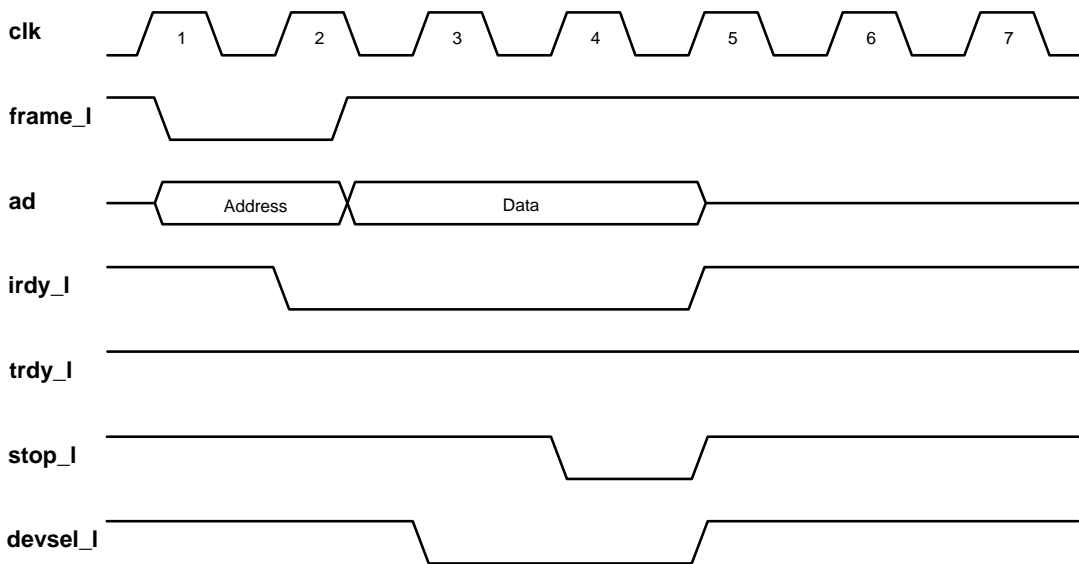

LJ-04842.WMF

5.5.2 Master-Initiated Termination

A master-initiated termination can occur when the 21143 operates as a master device on the PCI bus. Terminations can be issued by either the 21143 or the memory controller.

The 21143 can perform the following terminations:

- Normal completion

- Timeout

- Master abort

The memory-controller can perform the following terminations (target):

- Target abort

- Target disconnect

- Target retry

5.5.2.1 21143-Initiated Termination

A 21143-initiated termination occurs when **frame_1** is deasserted and **irdy_1** is asserted. This indicates to the memory controller that the final data phase is in progress. The final data transfer occurs when both **irdy_1** and **trdy_1** assert. The transaction completes when both **frame_1** and **irdy_1** deassert. This is an idle bus condition.

Normal Completion

Figure 5–9 shows a normal completion cycle termination. This indicates that the 21143 successfully completed its intended transaction.

Termination Cycles

Figure 5–9 Normal Completion

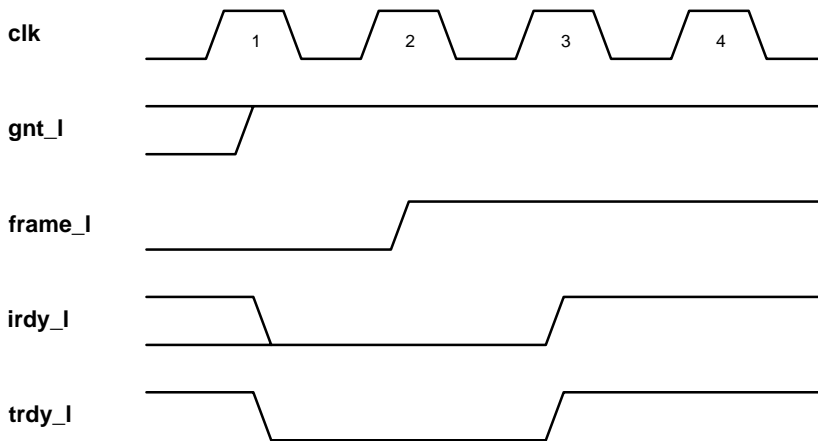

LJ-04730.WMF

Timeout

A timeout cycle termination occurs when the **gnt_l** line has been deasserted by the arbiter and the 21143 internal latency timer has expired. However, the intended transaction has not completed. A maximum of two additional data phases are permitted and then the 21143 performs a normal transaction completion.

Master Abort

If the target does not assert **devsel_l** within five cycles from the assertion of **frame_l**, the 21143 performs a normal completion. It then releases the bus and asserts both master abort (CFCS<29>) and fatal bus error (CSR5<13>). Figure 5–10 shows the 21143 master abort termination.

Figure 5–10 Master Abort

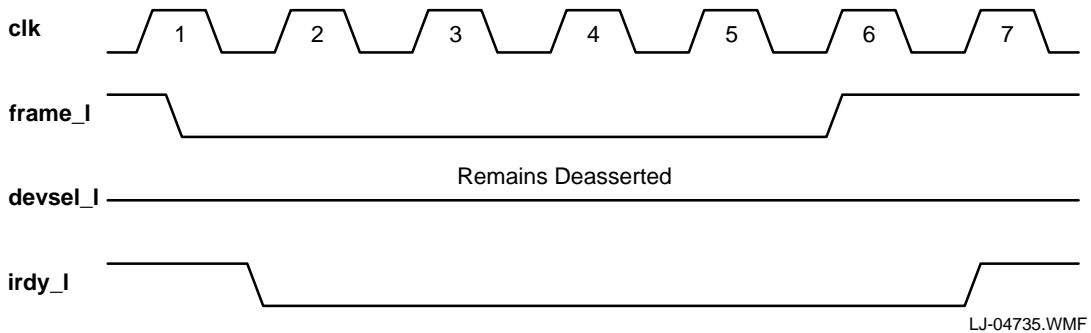

LJ-04735.WMF

5.5.2.2 Memory-Controller-Initiated Termination

The memory controller or target can initiate certain terminations when the 21143 is the bus master.

Target Abort

The 21143 aborts the bus transaction when the target asserts **stop_I** and deasserts **devsel_I**. This indicates that the target wants the transaction to be aborted. The 21143 releases the bus and asserts both received target abort (CFCS<28>) and fatal bus error (CSR5<15>). Figure 5–11 shows the 21143 target abort.

Termination Cycles

Figure 5–11 Target Abort

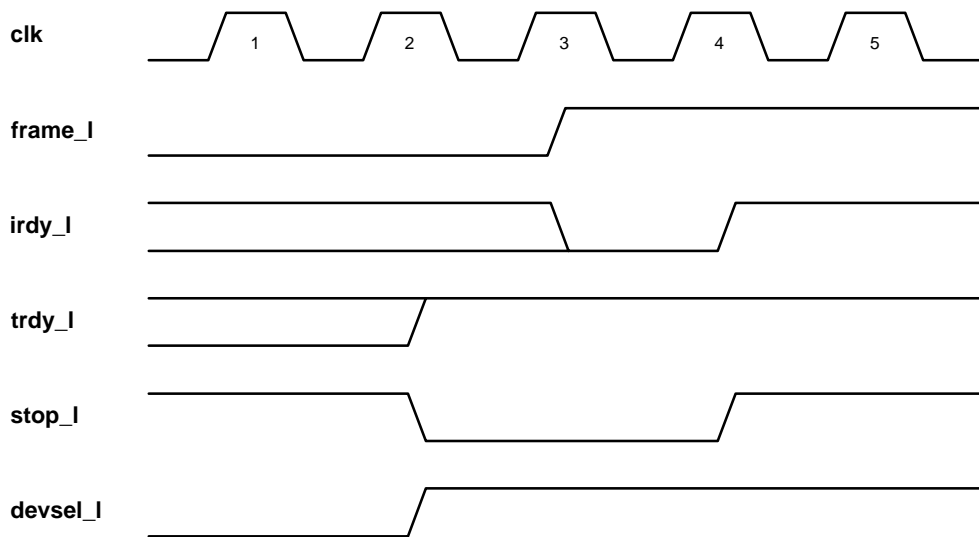

LJ-04731.WM

Target Disconnect Termination

The 21143 terminates the bus transaction when the target asserts **stop_1**, which remains asserted until **frame_1** is deasserted. The 21143 releases the bus. Then, it retries at least the last data transaction after regaining the bus in another arbitration. Figure 5–12 shows the 21143 target disconnect.

Figure 5–12 Target Disconnect

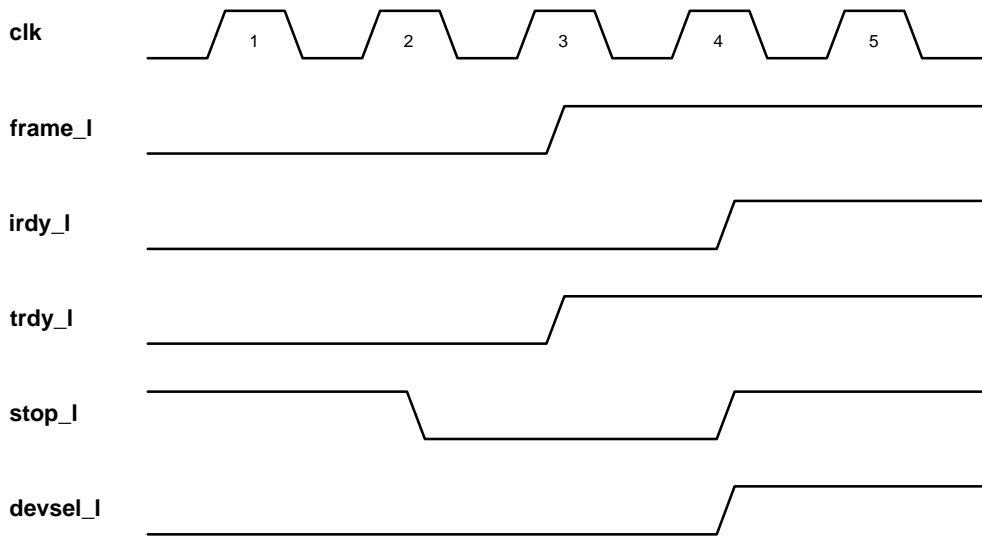

LJ-04732.WMF

Target Retry

The 21143 retries the bus transaction when the target asserts **stop_l** and deasserts **trdy_l**; **stop_l** remains asserted until **frame_l** is deasserted. The 21143 releases the bus. Then, it retries at least the last two data transactions after regaining the bus in another arbitration. Figure 5–13 shows the 21143 target retry.

Parity

Figure 5–13 Target Retry

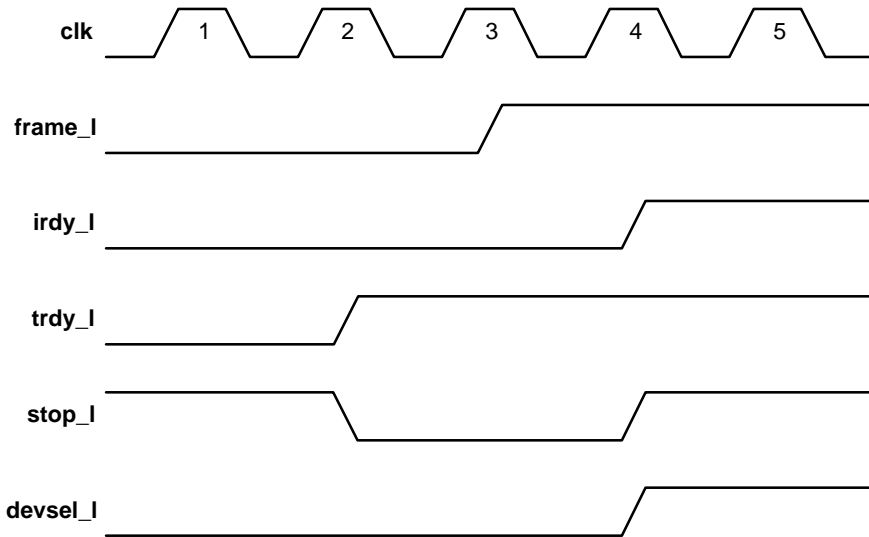

LJ-04097.WMF

5.6 Parity

The 21143 supports parity generation on all address, data, and command bits. Parity is always checked and generated on the 32-bit address and data bus (**ad**) as well as on the four command (**c_be_l**) lines. The 21143 always transfers stable values (1 or 0) on all the **ad** and **c_be_l** lines. If a data parity error is detected or **perr_l** is asserted when the 21143 is a bus master, the 21143 asserts data parity report (CFCS<24>) and fatal bus error (CSR5<13>).

Figure 5–14 shows an example of parity generation on a memory write burst transaction. Note that valid parity is generated one cycle after the address and data segments were generated on the bus. One cycle after the assertion of the address parity, **serr_l** is asserted for one cycle because of an address parity error during slave operation. One cycle after the assertion of the data parity, **perr_l** is asserted because of a parity data error in either slave write or master read operations.

Figure 5–14 Parity Operation

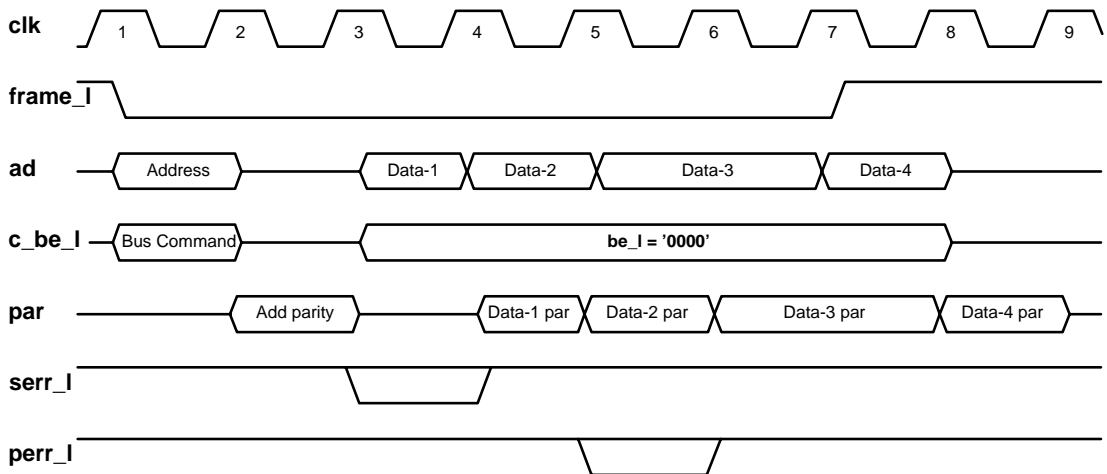

LJ-04736.WMF

5.7 Parking

Parking in the PCI bus allows the central arbiter to pause any selected agent. The 21143 enters the parking state when the arbiter asserts its **gnt_I** line while the bus is idle.

5.8 PCI/CardBus Clock Control through Clkrun

In order to reduce power consumption during idle time, a PCI/CardBus system can dynamically control the bus clock using the **clkrun_I** line. The host asserts this line to indicate normal operation of the system clock. It may deassert this line to indicate to devices connected to the bus that the clock is going to be stopped or slowed down to a nonoperational frequency. A device connected to the bus may reject the request to stop the clock by asserting **clkrun_I** line.

The 21143 requests that the system clock be maintained when one or more of the following conditions is true:¹

- PCI slave or master access is in progress
- Serial ROM interface is active

¹The 21143–PB, 21143–TB, 21143–PC, and the 21143–TC continuously request the host for the clock, which prevents the clock from stopping or slowing down.

PCI/CardBus Clock Control through Clkrun

- Boot ROM port is active
- Transmit is in progress
- Receive is in progress
- Carrier is sensed
- Link pass or link fail interrupt is pending
- Hardware or software reset is in progress
- The 21143 is set to normal mode and is not in D2 or D3
- Func0_HwOptions<4> (EnableCLKRUN) in the serial ROM is cleared
- Receive interrupt is pending for timer expiration in the interrupt mitigation mechanism

The 21143 requests that the system clock be restored, when one or more of the following events occur:

- PCI slave access
- Carrier is sensed on the LAN
- Power-management event was detected
- Link change event was detected
- Autonegotiation is completed

Figure 5–15 shows the PCI/CardBus clock restart or speed-up timing characteristics.

Figure 5–15 PCI/CardBus Clock—Restart or Speed-Up

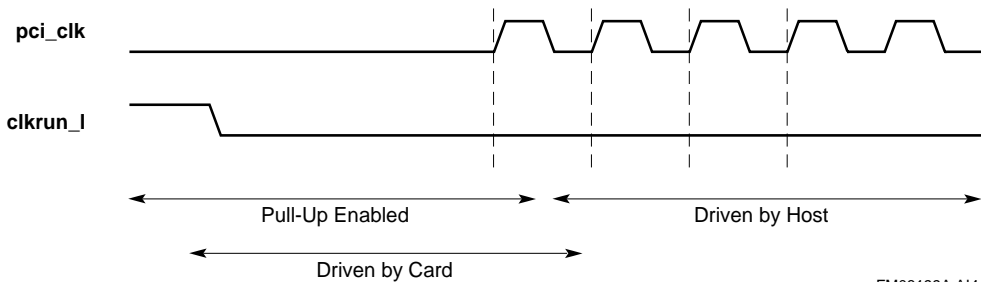

FM06199A.A14

PCI/CardBus Clock Control through Clkrun

Figure 5–16 shows the maintaining PCI/CardBus clock timing characteristics.

Figure 5–16 PCI/CardBus Clock—Maintaining Speed

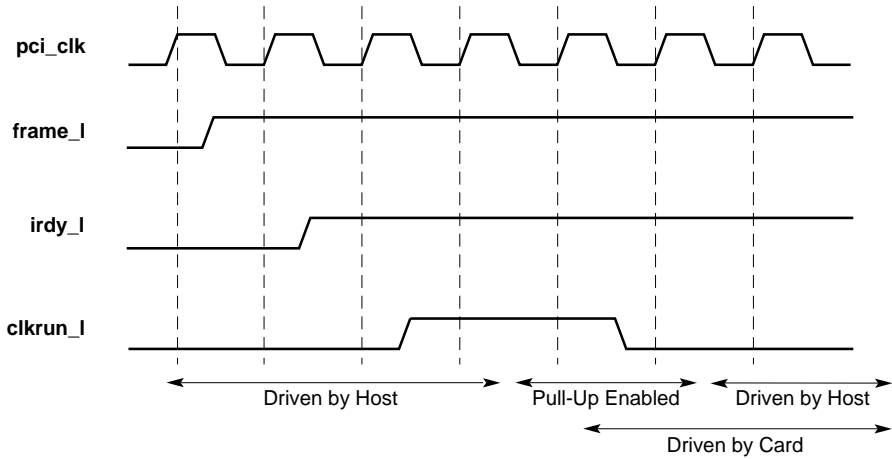

FM06198A.A14

While the PCI/CardBus clock is stopped through clkrun, interrupts from the general-purpose port are not issued.

Network Interface Operation

This chapter describes the operation of the MII/SYM port, the 10BASE-T port, and the AUI port. It also describes media access control (MAC), loopback, and full-duplex operations. Appendix D describes the port selection procedure.

6.1 MII/SYM Port

This section provides a description of the 100BASE-T terminology, the interface, the signals used, and the operating modes.

6.1.1 100BASE-T Terminology

This subsection provides a description of the 100BASE-T terminology used for the MII/SYM port. A list of these terms follows:

- Media-independent interface (MII) is defined between the media access control (MAC) sublayer and the physical layer protocol (PHY) layer.
- Physical coding sublayer (PCS) is a sublayer within the PHY defined by 100BASE-T. The PCS implements the higher level functions of the PHY.
- 100BASE-T is a generic term that refers to all members in the IEEE 802.3 family of 100-Mb/s carrier-sense multiple access with collision detection (CSMA/CD) standards.
- 100BASE-T4 is the standard IEEE 802.3 for 100 Mb/s, using unshielded twisted-pair (UTP) category 3 (CAT3) cables. The PHY requires four pairs.
- 100BASE-X refers to all members of the IEEE 802.3 family contained in the 100-Mb/s CSMA/CD standard. It implements a specific physical medium attachment (PMA) and PCS. Members of this family include 100BASE-TX and 100BASE-FX.

MII/SYM Port

- 100BASE-TX refers to the IEEE 802.3 PHY layer, which includes the 100BASE-X PCS and PMA together with the physical layer medium dependent (PMD). It uses UTP category 5 (CAT5) cables and STP cables.
- 100BASE-FX refers to the IEEE 802.3 PHY layer, which includes the 100BASE-X PCS and PMA together with the PMD. It uses multimode fiber.

6.1.2 Interface Description

The MII port is an IEEE 802.3 compliant interface that provides a simple, inexpensive, and easily implemented interconnection between the MAC sublayer and the PHY layer. It also interconnects the PHY layer devices and station management (STA) entities. This interface has the following characteristics:

- Supports both 100-Mb/s and 10-Mb/s data rates
- Contains data and delimiters that are synchronous to clock references
- Provides independent, 4-bit-wide transmit and receive data paths
- Uses TTL signal levels, compatible with common CMOS application-specific integrated circuit (ASIC) processes
- Provides a simple management interface

6.1.2.1 Signal Standards

Table 6–1 provides the standards that reference the MII/SYM port signal names with the appropriate IEEE 802.3 signal names.

Table 6–1 IEEE 802.3 and MII/SYM Signals

(Sheet 1 of 2)

MII/SYM Signals	IEEE 802.3 Signals	Purpose
mii_clsn	COL	Collision detect is asserted by the PHY layer when it detects a collision on the medium. It remains asserted while this condition persists. For the 10-Mb/s implementation, collision is derived from the signal quality error of the PMA. For the 100-Mb/s implementation, collision is defined for each PHY layer separately.
mii_crs	CRS	Carrier sense is asserted by the PHY layer when either the transmit or receive medium is active (not idle).

Table 6–1 IEEE 802.3 and MII/SYM Signals

(Sheet 2 of 2)

MII/SYM Signals	IEEE 802.3 Signals	Purpose
mii_dv	RX_DV	Receive data valid is asserted by the PHY layer when the first received preamble nibble is driven over the MII/SYM and remains asserted for the remainder of the frame.
mii_rx_err	RX_ERR	Receive error is asserted by the PHY layer to indicate either a coding error or any other type of error that the MAC cannot detect was received. This error was detected on the frame currently being received and transferred over the MII/SYM.
mii_mdc	MDC	Management data clock is the clock reference for the mii_mdio signal.
mii_mdio	MDIO	Management data input/output is used to transfer control signals between the 21143 and the PHY chip. The 21143 is capable of initiating the transfer of control signals to and from the PHY device by using this line.
mii/sym_rclk	RX_CLK	Receive clock synchronizes all receive signals.
mii/sym_rxd<3:0>	RXD<3:0>	These lines provide receive data.
mii/sym_tclk	TX_CLK	Transmit clock synchronizes all transmit signals.
mii/sym_txd<3:0>	TXD<3:0>	These lines provide transmit data.
mii_txen	TX_EN	Transmit enable is asserted by the MAC sublayer when the first transmit preamble nibble is driven over the MII/SYM and remains asserted for the remainder of the frame.
Note:	The remaining three signals are activated when the MII/SYM port uses either the 100BASE-TX or 100BASE-FX applications.	
mii_sd	—	Signal detect indication is supplied by an external PMD device.
sym_rxd<4>	—	This line is used for receive data.
sym_txd<4>	—	This line is used for transmit data.

MII/SYM Port

6.1.2.2 Operating Modes

The 21143 implements the MII/SYM port signals (Table 6–1) to support the following operating modes:

- **MII 100-Mb/s mode**—The 21143 implements the MII with a data rate of 100 Mb/s and both the receive clock (**mii/sym_rclk**) and the transmit clock (**mii/sym_tclk**) operate at 25 MHz. In this mode, the 21143 can be used with any device that implements the 100BASE-T PHY layer (for example, 100BASE-TX, 100BASE-FX, or 100BASE-T4) and an MII.
- **MII 10-Mb/s mode**—The 21143 implements the MII with a data rate of 10 Mb/s and both the receive clock **mii/sym_rclk** and the transmit clock **mii/sym_tclk** operate at 2.5 MHz. In this mode, the 21143 can be used with any device that implements the 10-Mb/s PHY layer and an MII.
- **100BASE-TX mode**—The 21143 implements certain functions of the PCS for STP PMD and UTP CAT5 PMD. The receive symbols are 5 bits wide and are transferred over the **mii/sym_rxd<3:0>** and **sym_rxd<4>** lines. The transmit symbols are also 5 bits wide and are transferred over the **mii/sym_txd<3:0>** and **sym_txd<4>** lines. The 21143 implements the following functions:
 - 4-bit and 5-bit decoding and encoding
 - Start-of-stream delimiter (SSD) and end-of-stream delimiter (ESD) detection and generation
 - Bit alignment
 - Carrier detect
 - Collision detect
 - Symbol error detection
 - Scrambling and descrambling
 - Link timer

This mode enables a direct interface with existing fiber distributed data interface (FDDI) TP-PMD devices that implement the physical functions.

- **100BASE-FX mode**—The 21143 implements certain functions of the PCS sublayer for multimode fiber. The receive symbols are 5 bits wide and are transferred over the **mii/sym_rxd<3:0>** and **sym_rxd<4>** lines. The transmit symbols are also 5 bits wide and are transferred over the **mii/sym_txd<3:0>** and **sym_txd<4>** lines. The 21143 implements the following functions:

10BASE-T and AUI Functions

- 4-bit and 5-bit decoding and encoding
- SSD and ESD detection and generation
- Bit alignment
- Carrier detect
- Collision detect
- Symbol error detection
- Link timer

This mode enables a direct interface with existing FDDI TP-PMD devices that implement the physical functions.

Note: The SSD detection logic compares the incoming data to JK and not to IJK (this complies with IEEE 802.3, draft number 2).

6.2 10BASE-T and AUI Functions

The 10BASE-T and AUI protocols include the following functions:

- Supports data driver and is receiver compatible with 10BASE-T specifications
- Supports data driver and is receiver compatible with AUI specifications
- Provides AUI collision receiver compatible with AUI specifications
- Selects either AUI or 10BASE-T interfaces
- Implements Manchester decoder for incoming data
- Implements Manchester encoder for outgoing data
- Contains onchip, 20-MHz crystal oscillator circuitry
- Enables watchdog timers on incoming and outgoing data
- Contains 10BASE-T enhanced features that include:
 - Smart squelch, rejecting noise detected by the 10BASE-T receiver interface
 - Combined autopolarity and link test detection, presenting a robust algorithm for detection of both wire failure and switching of wires. Polarity correction is automatically done, while wire failure is reported to higher layers.

10BASE-T and AUI Functions

6.2.1 Receivers and Drivers

The host selects one set of data receivers and drivers at a time: either AUI or Twisted-Pair (TP). The other receiver and driver sets are enabled too, unless CSR14<15> (10BASE-T/AUI autosensing enable) is reset.

6.2.2 Manchester Decoder

The Manchester decoder is a phase-locked loop decoder that provides received clocks and data to the media access control (MAC) interface (Section 6.3).

6.2.3 Manchester Encoder

The Manchester encoder receives clocked data from the transmit engine and uses the 20-MHz clock to provide Manchester encoded data. The encoder provides the transition to idle for the AUI and TP drivers.

6.2.4 Oscillator Circuitry

The 21143 supports two options for generating the internal 10-MHz clock required by the internal circuitry.

1. An external parallel resonant crystal connected between **xtal1** and **xtal2** to drive the 21143-integrated oscillator circuitry.
2. An external clock generator module connected to **xtal1**; **xtal2** remains unconnected.

In both cases, the 21143 must be provided with a 20-MHz signal that is internally divided by 2 to generate the 10-MHz clock.

When driving the oscillator from an external clock source, an external clock having the following characteristics must be used to ensure proper operation of the 21143:

- Clock frequency: 20-MHz \pm 0.01% (100 ppm, TTL, or CMOS)
- Rise/fall time: < 4 ns
- Duty cycle: 40%–60%

Table 6–2 lists the specifications for the crystal oscillator.

Table 6–2 Crystal Oscillator Specification

Category	Value
Frequency	20 MHz
Tolerance	±0.01% at 25°C (100 ppm)
Stability	±0.005% at 0°C to 70°C (100 ppm)

6.2.5 Smart Squelch

The 21143 implements an intelligent squelch on its TP receiver to ensure that impulse noise detected on the receive inputs is not mistaken for valid signals. The squelch circuitry employs a combination of both amplitude and timing measurements to determine the validity of data received on the TP inputs.

The squelch circuit allows only valid differential receive data to pass through to the Manchester decoder provided that the following two conditions are satisfied:

1. The input amplitude is greater than the minimum signal threshold level.
2. A specific pulse sequence is received.

Satisfying these two conditions ensures that a good signal-to-noise ratio is maintained while the signal pair is active, and it prevents system noise from causing false squelch deactivation.

The line squelch quickly activates and deactivates within the specified time intervals, when the input squelch threshold is exceeded and a specific pulse sequence of proper polarity is detected.

The squelch circuitry rejects system noise by ignoring received pulses that are less than the required fixed time width. It also rejects pulses that are greater than the expected signal duration.

6.2.6 Autopolarity Detector

The autopolarity detector (CSR14<13>) provides a method of detecting receive wire polarity by switching the polarity of the data going into the MAC layer accordingly. To detect polarity, the 21143 uses the link test pulse and the end-of-frame delimiter in an algorithm integrated into the link integrity test, as specified in the IEEE 802.3 10BASE-T supplement.

10BASE-T and AUI Functions

6.2.7 Network Port Autosensing

The 21143 can sense the AUI and 10BASE-T ports at the same time. In addition, while the AUI port is used for transmission, it can also send the 10BASE-T link pulses onto the TP wires. These features, along with reported status bits and interrupts, together with indications taken from the 100BASE-T PHY chip located on the board, allow the driver to choose between the three ports for network connection without any network configuration information.

To implement the autosensing algorithm, the driver can use the following hardware support provided by the 21143 (a detailed description of these bits is provided in Chapter 3):

- Interrupts
 - Link pass CSR5<4>
 - Link fail CSR5<12>
 - Timer expired CSR5<11>
- CSRs
 - Autosensing enable bit CSR14<15>
 - Activity sensed on the AUI port CSR12<8>
 - Activity sensed on the 10BASE-T port CSR12<9>
 - Activity sensed on the MII port CSR12<10>
 - General-purpose timer (CSR11)

Additional information about the MII port activity can be taken from the 100BASE-T PHY chip located on the board through the MII management port (**mii_mdc** and **mii_mdio**).

Selecting one of the serial ports requires programming of CSR6, CSR13, CSR14, and CSR15. Table 3–100 provides the programming values for autosensing enabling. To change the selection, start by resetting the SIA using CSR13.

6.2.8 10BASE-T Link Integrity Test

Before transmitting on an Ethernet CSMA/CD network, each device has to check the reliability of its receive lines. For the AUI connection, this is indicated by the carrier signal present during transmission. In the twisted-pair (TP) case, link pulses are sent every 8 ms to 24 ms at the interval between two transmissions.

The 21143 monitors the received link pulses and end-of-frame delimiters to be spaced and electrically shaped as specified in the IEEE 802.3 10BASE-T supplement. Accordingly, the 21143 implements the Link Integrity Test.

After a software or hardware reset, the 21143 wakes up in the link fail state. In this state, only link pulses are sent onto the transmit lines. Upon detection of the required line activity, and autonegotiation completion (if enabled), the 21143 enters the link pass state enabling the receive and transmit paths.

A broken or noisy wire can bring the 21143 back to the link fail state. It will then report the wire failure by generating a link fail interrupt to the host and will immediately stop the receive and transmit paths. These paths will not be enabled again until the Link Integrity Test ends successfully.

6.3 Media Access Control Operation

The 21143 supports a full implementation of the MAC sublayer of IEEE 802.3. It can operate in half-duplex mode, full-duplex mode, and loopback mode.

6.3.1 MAC Frame Format

The 21143 handles both IEEE 802.3 and Ethernet MAC frames. While operating in either the 100BASE-FX mode or 100BASE-TX mode, the 21143 encapsulates the frames it transmits according to the IEEE 802.3, clause 24. Receive frames are decapsulated according to the IEEE 802.3, clause 24.

The changes between a MAC frame (Section 6.3.1.1) and the encapsulation used when operating either in 100BASE-TX or 100BASE-FX mode are listed as follows:

1. The first byte of the preamble in the MAC frame is replaced with the JK symbol pair.
2. After the frame check sequence (FCS) byte of the MAC frame, the TR symbol pair is inserted.

Media Access Control Operation

6.3.1.1 Ethernet and IEEE 802.3 Frames

Ethernet is the generic name for the network type. An Ethernet frame has a minimum length of 64 bytes and a maximum length of 1518 bytes, exclusive of the preamble and the start frame delimiter.

An Ethernet frame format consists of the following parts:

- Preamble
- Start frame delimiter (SFD)
- Two address fields
- Type or length field
- Data field
- Frame check sequence (CRC value)

6.3.1.2 Ethernet Frame Format Description

Figure 6–1 shows the Ethernet frame format.

Figure 6–1 Ethernet Frame Format

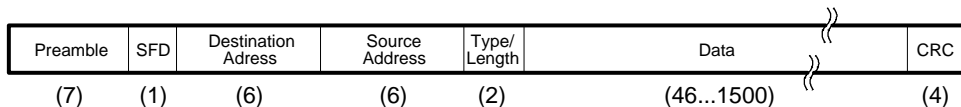

Numbers in parentheses indicate field length in bytes.

LJ-04098.WMF

Table 6–3 describes the Ethernet frame format.

Table 6–3 Ethernet Frame Format

(Sheet 1 of 2)

Field	Description
Preamble	A 7-byte field of 56 alternating 1s and 0s, beginning with a 0.
SFD—Start frame delimiter	A 1-byte field that contains the value 10101011; the most significant bit is transmitted and received first.
Destination address	A 6-byte field that contains either a specific station address, the broadcast address, or a multicast (logical) address where this frame is directed.
Source address	A 6-byte field that contains the specific station address where this frame originated.

Table 6–3 Ethernet Frame Format

(Sheet 2 of 2)

Field	Description
Type/length	A 2-byte field that indicates whether the frame is in IEEE 802.3 format or Ethernet format (Table 6–4). A field greater than 1500 is interpreted as a type field, which defines the type of protocol of the frame. A field smaller than or equal to 1500 (05-DC) is interpreted as a length field, which indicates the number of data bytes in the frame.
Data	A data field consists of 46 bytes to 1500 bytes of information that is fully transparent because any arbitrary sequence of bits can occur. A data field shorter than 46 bytes, which is specified by the length field, is allowed. Unless padding is disabled (TDES1<23>), it is added by the 21143 when transmitting to fill the data field up to 46 bytes.
CRC	A frame check sequence is a 32-bit cyclic redundancy check (CRC) value that is computed as a function of the destination address field, source address field, type field, and data field. The FCS is appended to each transmitted frame, and is used at reception to determine if the received frame is valid.

Table 6–4 lists the possible values for the frame format. The values are expressed in hexadecimal notation and the 2-byte field is displayed with a hyphen separating the 2 bytes. The byte on the left of the hyphen is the most significant byte and is transmitted first.

Table 6–4 Frame Format Table

Frame Format	Length or Type	Hexadecimal Value
IEEE 802.3	Length field	00-00 to 05-DC
Ethernet	Type field	05-DD to FF-FF

The CRC polynomial, as specified in the Ethernet specification, is as follows:

$$FCS(X) = X^{31} + X^{26} + X^{23} + X^{22} + X^{16} + X^{12} + X^{11} + X^{10} + X^8 + X^7 + X^5 + X^4 + X^2 + X^1 + 1$$

The 32 bits of the CRC value are placed in the FCS field so that the X^{31} term is the right-most bit of the first octet, and the X^0 term is the left-most bit of the last octet. The bits of the CRC are thus transmitted in the order $X^{31}, X^{30}, \dots, X^1, X^0$.

Media Access Control Operation

6.3.2 Ethernet Reception Addressing

The 21143 can be set up to recognize any one of the Ethernet receive address groups described in Table 6–5. Each group is separate and distinct from the other groups.

Table 6–5 Ethernet Receive Address Groups

Group	Description
1	<p>16-address perfect filtering</p> <p>The 21143 provides support for the perfect filtering of up to 16 Ethernet physical or multicast addresses. Any mix of addresses can be used for this perfect filter function of the 21143. The 16 addresses are issued in setup frames to the 21143.</p>
2	<p>One physical address, unlimited multicast addresses imperfect filtering</p> <p>The 21143 provides support for one, single physical address to be perfectly filtered with an unlimited number of multicast addresses to be imperfectly filtered. This case supports the needs of applications that require one, single physical address to be filtered as the station address, while enabling reception of more than 16 multicast addresses, without suffering the overhead of pass-all-multicast mode. The single physical address, for perfect filtering, and a 512-bit mask, for imperfect filtering using a hash algorithm, are issued in a setup frame to the 21143. When hash hits are detected, the 21143 delivers the received frame (Section 4.2.3)</p>
3	<p>Unlimited physical addresses, unlimited multicast addresses imperfect filtering</p> <p>The 21143 provides support for unlimited physical addresses to be imperfectly filtered with an unlimited number of multicast addresses to be imperfectly filtered as well. This case supports applications that require more than one physical address to be filtered as the station address, while enabling the reception of more than 16 multicast addresses, without suffering the overhead of pass-all-multicast mode. A 512-bit mask, for imperfect filtering using a hash algorithm, is issued in a setup frame to the 21143. When hash hits are detected, the 21143 delivers the received frame (Section 4.2.3).</p>
4	<p>Promiscuous Ethernet reception</p> <p>The 21143 provides support for reception of all frames on the network regardless of their destination. This function is controlled by a CSR bit. This group is typically used for network monitoring.</p>
5	<p>16-address perfect filtering and reception of all multicast Ethernet addresses</p> <p>This group augments the receive address Group 1 and also receives all frames on the Ethernet with a multicast address.</p>
6	<p>16-address inverse filtering</p> <p>In this mode, the 21143 applies the reverse filter of Group 1. The 21143 provides support for the rejection of up to 16 Ethernet physical or multicast addresses. Any mix of addresses may be used for this filter function of the 21143. The 16 addresses are issued in setup frames to the 21143.</p>

6.3.3 Detailed Transmit Operation

This section describes the transmit operation in detail, as supported by the 21143. This description includes the specific control register definitions, setup frame definitions, and a mechanism used by the host processor software to manipulate the transmit list (that is, the descriptors and buffers that can be found in Section 4.2).

6.3.3.1 Transmit Initiation

The host CPU initiates a transmit by storing the entire information content of the frame to be transmitted in one or more buffers in memory. The host processor software prepares a companion transmit descriptor, also in host memory, for the transmit buffer and signals the 21143 to take it. After the 21143 has been notified of this transmit list, the 21143 starts to move the data bytes from the host memory to the internal transmit FIFO.

When the transmit FIFO is adequately filled to the programmed threshold level, or when there is a full frame buffered into the transmit FIFO, the 21143 begins to encapsulate the frame.

The threshold level can be programmed with various quantities (Table 3–72). The lower threshold is for low bus latency systems and the high threshold is for high bus latency systems.

The transmit encapsulation is performed by the transmit state machine, which delays the actual transmission of the data onto the network until the network has been idle for a minimum interpacket gap (IPG) time.

6.3.3.2 Frame Encapsulation

The transmit data frame encapsulation stream consists of appending the 56 preamble bits together with the SFD to the basic frame beginning and the FCS (for example, CRC), to the basic frame end.

The basic frame read from the host memory includes the destination address field, the source address field, the type/length field, and the data field. If the data field length is less than 46 bytes, and padding (TDES1<23>) is enabled, the 21143 pads the basic frame with the pattern 00 for up to 46 bytes before appending the FCS field to the end.

While operating either in 100BASE-FX mode or 100BASE-TX mode, the 21143 encapsulates the frames it transmits according to IEEE 802.3, clause 24 and the receive frames are decapsulated as defined in IEEE 802.3, clause 24.

Media Access Control Operation

The changes between a MAC frame (Section 6.3.1) and the encapsulation used when operating either in 100BASE-TX or 100BASE-FX modes are listed as follows:

1. The first byte of the preamble in the MAC frame is replaced with the JK symbol pair.
2. After the FCS byte of the MAC frame, the TR symbol pair is inserted.

6.3.3.3 Initial Deferral

The 21143 constantly monitors the line and can initiate a transmission any time the host CPU requests it. Actual transmission of the data onto the network occurs only if the network has been idle for a 96-bit time period, and any backoff time requirements have been satisfied.

The IPG time is divided into two parts: IPS1 and IPS2.

1. IPS1 time (60-bit time): the 21143 monitors the network for an idle state. If a carrier is sensed on the serial line during this time, the 21143 defers and waits until the line is idle again before restarting the IPS1 time count.
2. IPS2 time (36-bit time): the 21143 continues to count time even though a carrier has been sensed on the network, and thus forces collisions on the network. This enables all network stations to have access to the serial line.

6.3.3.4 Collision

A collision occurs when concurrent transmissions from two or more Ethernet nodes take place. When the 21143 detects a collision while transmitting, it halts the transmission of the data, and instead, transmits a jam pattern consisting of hexadecimal AAAAAAAAAA. At the end of the jam transmission, the 21143 begins the backoff wait period.

If the collision was detected during the preamble transmission, the jam pattern is transmitted after completing the preamble (if the 21143 is in 100BASE-FX or 100BASE-TX operating modes, this includes the JK symbol pair as described in Section 6.3.4.2.2). This action results in a minimum 96-bit fragment.

The 21143 scheduling of retransmission is determined by a controlled randomization process called truncated binary exponential backoff. The delay is an integer multiple of slot times. The number of slot times of delay before the n th retransmission attempt is chosen as a uniformly distributed random integer r in the range:

$$0 \leq r < 2^k$$
$$k = \min(n, N) \text{ and } N = 10$$

When 16 attempts have been made at transmission and all have been terminated by a collision, the 21143 sets an error status bit in the descriptor (TDES0<8>) and, if enabled, issues a normal transmit termination (CSR5<0>) interrupt to the host.

Note: The jam pattern is a fixed pattern that is not compared with the actual frame CRC. This has the very low probability (0.5^{32}) of having a jam pattern equal to the CRC.

6.3.3.5 Terminating Transmission

A specific frame transmission is terminated by any of the following conditions:

- Normal—The frame has been transmitted successfully. When the last byte is serialized, the pad and CRC are optionally appended and transmitted, thus concluding frame transmission.
- Underflow—Transmit data is not ready when needed for transmission. The underflow status bits (TDES0<1> and CSR5<5>) are set, and the packet is terminated on the network with a bad CRC.
- Excessive collisions—If a collision occurs for the 15th consecutive retransmission attempt of the same frame, TDES0<8> is set.
- Jabber timer expired—If the timer expires (TDES0<14> sets) while transmission continues, the programmed interval transmission is cut off.
- Memory error—This generic error indicates either a host bus timeout or a host memory error.
- Late collision—If a collision occurs after the collision window (transmitting at least 64 bytes), transmission is cut off and TDES0<9> sets.

At the completion of every frame transmission, status information about the frame is written into the transmit descriptor. Status information is written into CSR5 if an error occurs during the operation of the transmit machine itself. If a normal interrupt summary (CSR7<16>) is enabled, the 21143 issues a normal transmit termination interrupt (CSR5<0>) to the host.

Media Access Control Operation

6.3.3.6 Transmit Parameter Values

Table 6–6 lists the transmit parameter values for both the 10-Mb/s and 100-Mb/s serial bit rates.

Table 6–6 Transmit Parameter Values

Parameter	Condition	Value
Defer time	IPS1+IPS2=96-bit time period	—
IPS1	—	60-bit time period
IPS2	—	36-bit time period
Slot time interval	—	512-bit time period
Network acquisition time	—	512-bit time period
Transmission attempts	—	16
Backoff limit	—	10
Jabber timer	Default	16,000-bit to 20,000-bit time period
Jabber timer	Programmable range	26,000-bit to 32,000-bit time period

6.3.4 Detailed Receive Operation

This section describes the detailed receive operation as supported by the 21143. This description includes the specific control register definitions, setup frame definitions, and a mechanism used by the host processor software to manipulate the receive list (that is, the descriptors and buffers that can be found in Section 4.2).

6.3.4.1 Receive Initiation

The 21143 continuously monitors the network when reception is enabled. When activity is recognized, it starts to process the incoming data. After detecting receive activity on the line, the 21143 starts to process the preamble bytes based on the mode of operation.

6.3.4.2 Preamble Processing

Preamble processing varies depending on the 21143 operating mode. The next two subsections describe how this processing is handled.

6.3.4.2.1 MII/SYM, 10BASE-T, or AUI Mode Preambles

In MII/SYM, 10BASE-T, or AUI mode, the preamble, as defined by Ethernet, can be up to 64 bits (8 bytes) long.

The 21143 allows any arbitrary preamble length. However, depending on the mode, there is a minimum preamble length.

- In MII/SYM mode, at least 8 bits are required to recognize a preamble.
- In 10BASE-T or AUI mode, at least 16 bits are required to recognize a preamble.
- While in snooze mode, at least 20 bits are required to recognize a preamble. This is true for MII/SYM, 10BASE-T, and AUI modes.

Recognition occurs as follows:

- In MII/SYM mode, the 21143 checks for the start frame delimiter (SFD) byte content of 10101011.
- In 10BASE-T or AUI mode:
 1. The first 8 preamble bits are ignored.
 2. The 21143 checks for the start frame delimiter (SFD) byte content of 10101011.

While checking for SFD, if the 21143 receives an 11₂ (before receiving 14 bits in 10BASE-T or AUI mode or 6 bits in MII/SYM mode) or a 00₂ (everywhere), the reception of the current frame is aborted. The frame is not received, and the 21143 waits until the network activity stops (Section 6.3.4.1) before monitoring the network activity for a new preamble.

Figure 6–2 shows the preamble recognition sequence bit fields.

Figure 6–2 Preamble Recognition Sequence in 10BASE-T or AUI Mode

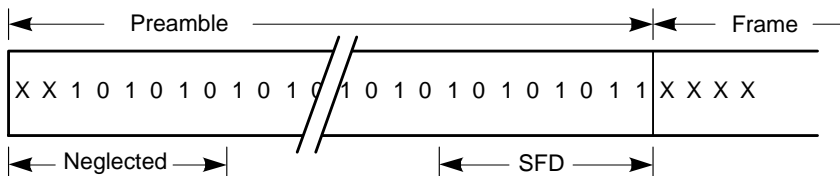

MLO10296.WMF

Media Access Control Operation

6.3.4.2.2 100BASE-TX or 100BASE-FX Mode Preambles

When operating in either 100BASE-TX or 100BASE-FX mode, the 21143 expects the frame to start with the symbol pair JK followed by the preamble, as specified in Section 6.3.4.2.1. If a JK symbol pair is not detected, the reception of the current frame is aborted (not received), and the 21143 waits until the network activity stops before monitoring the network activity for a new preamble.

6.3.4.3 Address Matching

Ethernet addresses consist of two 6-byte fields: one field for the destination address and one for the source address. The first bit of the destination address signifies whether it is a physical address or a multicast address as listed in Table 6–7.

Table 6–7 Destination Address Bit 1

Bit 1	Address
0	Station address (physical)
1	Multicast address

The 21143 filters the frame based on the Ethernet receive address group filtering mode that has been enabled (Section 6.3.2).

If the frame address passes the filter, the 21143 removes the preamble and delivers the frame to the host processor memory. If, however, the address does not pass the filter when the mismatch is recognized, the 21143 terminates its reception. In this case, no data is sent to the host memory nor is any receive buffer consumed.

If receive all (CSR6<30>) is set, the 21143 receives all incoming packets, regardless of the destination address. The address recognition status is posted in RDES0<30>.

6.3.4.4 Frame Decapsulation

The 21143 checks the CRC bytes of all received frames before releasing them to the host processor. When operating in either 100BASE-TX or 100BASE-FX mode, the 21143 also checks that the frame ends with the TR symbol pair; if not, the 21143 reports a CRC error in the packet reception status.

6.3.4.5 Terminating Reception

Reception of a specific frame is terminated when any of the following conditions occur:

- Normal termination—The network activity (Section 6.3.4.1) stops for the various operating modes.
- Overflow—The receive DMA cannot empty the receive FIFO into host processor memory as rapidly as it is filled, and an error occurs as frame data is lost.
- Watchdog timer expired —If the timer expires (CSR5<9> and RDES0<4> both set) while reception is still in process.
- Collision—If a late collision occurs after the reception of 64 bytes of the packet, the collision seen status bit RDES0<6> is set.

6.3.4.6 Frame Reception Status

When reception terminates, the 21143 determines the status of the received frame and loads it into the receive status word in the buffer descriptor. An interrupt is issued if enabled. The 21143 may report the following conditions at the end of frame reception:

- CRC error—The 32-bit CRC transmitted with the frame did not match the CRC calculated upon reception. The CRC check is always executed and is independent of any other errors. In addition, the 21143 reports a CRC error in any of the following cases:
 - The **mii_err** signal asserts during frame reception over the MII when operating in one of the MII operating modes.
 - The 21143 is operating in either the 100BASE-TX or 100BASE-FX mode and one of the following events occur:
 - * An invalid symbol is received in the middle of the frame.
 - * The frame does not end with the symbol T followed by the symbol R.
- Dribbling bits error—This indicates the frame did not end on a byte boundary. The 21143 signals a dribbling bits error only if the number of dribbling bits in the last byte is 4 in MII operating mode, or at least 3 in 10BASE-T/AUI serial operating mode. Only *whole bytes* are run through the CRC check. This means that although up to 7 dribbling bits may have occurred and a framing error was signaled, the frame might nevertheless have been received correctly.

Loopback Operations

- Alignment error—A CRC error and a dribbling bit error occur together. This means that the frame did not contain an integral number of bytes and the CRC check failed.
- Frame too short (runt frame)—A frame containing less than 64 bytes was received (including CRC). Reception of runt frames is optionally selectable. The 21143 defaults to inhibit reception of runts.
- Frame too long—A frame containing more than 1518 bytes (including CRC) was received. Reception of frames too long completes with an error indication.
- Collision seen—A frame collision occurred after the 64 bytes following the start frame delimiter (SFD) were received. Reception of such frames is completed and an error bit is set in the descriptor.
- Descriptor error—An error was found in one of the receive descriptors, which disabled the correct reception of an incoming frame.

6.4 Loopback Operations

The 21143 supports two loopback modes: internal loopback and external loopback. Both internal and external loopback require external clock activity (**mii_tclk** in MII mode and **xtal1** in 10BASE-T or AUI mode).

6.4.1 Internal Loopback Mode

Internal loopback mode is normally used to verify that the internal logic operations function correctly. Internal loopback mode is enabled according to CSR6<11:10>. Internal loopback mode includes all the internal functions. In loopback mode, the 21143 disengages from the Ethernet wire.

Internal loopback mode also supports the following modes of operation:

1. Media access control (MAC) internal loopback mode in which transmit packets are looped back at the MAC level and the 21143 disengages the SIA. The loopback data rate is 10 Mb/s, or 10/100 Mb/s in MII/SYM mode.
2. 10BASE-T internal loopback mode in which transmit packets from the encoder output are selected and looped back to the decoder input. The loopback data rate is 10 Mb/s.

6.4.2 External Loopback Mode

External loopback mode is normally used to verify that the logic operations up to the Ethernet cable function correctly. In external loopback mode, the 21143 takes frames from the transmit list and transmits them on the Ethernet wire. Concurrently, the 21143 listens to the line that carries its own transmissions and places incoming frames in the receive list.

Caution: In external loopback mode, when transmitted frames are placed on the Ethernet wire, the 21143 does not check the origin of any incoming frames. It is possible for frames not originating from the 21143 to enter the receive buffers.

External loopback mode also supports the following modes of operation:

- 10BASE-T external loopback mode transmits packets using twisted-pair wires. Concurrently, the 21143 disables the internal collision detector and thus listens to the line that carries its own transmission. The board designer must use an external shunt to connect the transmit line with the receive line.
- AUI external loopback mode transmits packets using the AUI cable up-to-MAU (medium attachment unit) to check the MAU integrity.
- MII/SYM external loopback mode transmits packets using the MII/SYM interface to check the MII/SYM integrity.

6.4.3 Driver Entering Loopback Mode

To enter a specific loopback mode, the driver must take the following actions:

Note: All address filtering and validity checking rules apply in all loopback modes.

1. Stop the receive and transmit processes by writing 0 to both the start/stop receive (CSR6<1>) and the start/stop transmit (CSR6<13>) fields. The driver must wait for any previously scheduled frame activity to cease by polling the transmit process state (<22:20>) and the receive process state (<19:17>) fields in CSR5.
2. Prepare the appropriate transmit and receive descriptor lists in host memory. These lists can follow the existing lists at the point of suspension or be new lists identified to the 21143 by the receive list base address in CSR3 and by the transmit list address in CSR4.

Full-Duplex Operation

3. Stop the SIA by setting CSR13 to a value of 00000000H.
4. In 10BASE-T/AUI mode, program CSR13, CSR14, and CSR15 to the desired SIA operation mode according to Table 3–100.
5. Wait at least 5 μ s.
6. Select the desired loopback mode according to Table 3–100.
7. Use start commands to place both the transmit and receive processes into the running state.
8. As in normal processing, execute any 21143 interrupts.

6.4.4 Driver Restoring Normal Operation

To restore normal operation, the driver must execute the following procedure:

1. Stop both the receive and transmit processes. The driver must wait for any previously scheduled frame activity to cease by polling both the transmit (CSR5<22:20>) and receive process state (CSR5<19:17>) fields in CSR5.
2. Prepare appropriate transmit and receive descriptor lists in host memory. These lists can either follow the existing lists at the point of suspension or be new lists that have to be identified to the 21143 by the receive list base address in CSR3 and the transmit list base address in CSR4.
3. Stop the SIA by setting CSR13 to a value of 00000000H.
4. In 10BASE-T/AUI mode, program CSR13, CSR14, and CSR15 to the desired SIA operation mode according to Table 3–100.
5. Wait at least 5 μ s.
6. Select normal mode operation according to Table 3–100.
7. Use start commands to place both the transmit and receive processes into the running state.
8. Resume normal processing. Execute any 21143 interrupts.

6.5 Full-Duplex Operation

The 21143 activates the transmit and receive processes simultaneously. It also supports receive back-to-back packets with an interpacket gap (IPG) of 96-bit times in parallel with transmit back-to-back packets with an IPG of 96-bit times.

The 21143 implements a programmable full-duplex operating mode (CSR6<9>) bit that commands the MAC to ignore both the carrier and the collision detect signal. In 10BASE-T mode, when the autonegotiation algorithm is used (CSR14<7>), the 21143 operates in full-duplex mode only if the negotiation results allow it. For additional information about programming full-duplex operation with autonegotiation, refer to Section 6.6.

The driver must take the following actions to enter full-duplex operation.

1. Stop the receive and transmit processes by writing 0 to CSR6<1> and CSR6<13> fields, respectively. The driver must wait for any previously scheduled frame activity to cease by polling the transmit process state (<22:20>) and receive process state (<19:17>) fields in CSR5.
2. Reset the SIA by writing 0 to CSR13.
3. Prepare appropriate transmit and receive descriptor lists in host memory. These lists can use the existing lists at the point of suspension, or can create new lists that must be identified to the 21143 by referencing the receive list base address in CSR3 and the transmit list base address in CSR4.
4. Set full-duplex mode (CSR6<9>).
5. In 10BASE-T/AUI mode, using Table 3–100 as a guide, set CSR13 through CSR15.
6. In 10BASE-T/AUI mode, wait for the link pass interrupt.
7. Place the transmit and receive processes in the running state by using the start commands.
8. Resume normal processing. Execute any 21143 interrupts.

6.6 Autonegotiation

The IEEE 802.3 10BASE-T autonegotiation algorithm allows a device to advertise enhanced modes of operation it possesses to a device at the remote end of a link segment. Similarly, a device can detect corresponding enhanced operation modes that the other device may be advertising. The algorithm builds upon the existing 10BASE-T link pulse scheme and is based on data exchange in the physical layer between two nodes.

The 21143 implements this algorithm for 10BASE-T and 100BASE-TX half-duplex and full-duplex mode autonegotiation and 100BASE-T4 mode autonegotiation. The whole negotiation is done by the 21143 without software involvement. At the end of the negotiation, the software should set the operating mode according to Table 6–8.

Autonegotiation

Table 6–8 Autonegotiation Modes Selection

CSR12<25:21> ¹	CSR14<18:16> ²	CSR14<6> ²	CSR6<9> ²	Selected Mode
X1XXX ³	X1X	X	X	100BASE-TX FD ⁴
XX1XX	001	X	X	100BASE-TX HD ⁵
001XX	XX1	X	X	100BASE-TX HD
XXX1X	000	X	1	10BASE-T FD
0001X	XXX	X	1	10BASE-T FD
XXXX1	000	1	0	10BASE-T HD
00001	XXX	1	X	10BASE-T HD
1XXXX	10X	X	X	T4
10XXX	1XX	X	X	T4
All other cases				No common mode

¹Link partner's link code word

²21143 advertisement

³Binary representation

⁴Full-duplex

⁵Half-duplex

If the selected mode at the end of negotiation is 10BASE-T, the receive and transmit paths are only enabled if the link integrity test passed successfully within 1 second. Otherwise, the autonegotiation process automatically starts again.

If the selected mode at the end of negotiation is 100BASE-TX, the driver should configure the 21143 to select the MII/SYM port (for more information, see Table 3–96). The receive and transmit paths are only enabled if the 100BASE-TX link integrity test passed successfully within 1 second. Otherwise, the autonegotiation process starts again.

In addition, when there is no common mode of operation between the two link partners, the autonegotiation process automatically starts once again within 1 second after negotiation has completed.

To enable the autonegotiation mechanism, CSR14<7> (autonegotiation enable) must be set. Table 3–100 shows the programming of the SIA with autonegotiation enabled.

Capture Effect—A Value-Added Feature

Before enabling its receive or transmit paths, or after the link integrity test has failed, the 21143 starts an autonegotiation sequence with its link partner. The 21143 stops sending its link pulses for at least 1 second and moves its link partner into the link fail state, forcing it to renegotiate.

An autonegotiation completed interrupt, together with CSR12<14:12> read as 101#2, indicates the end of the negotiation. The driver then reads CSR12 to get the link test status, and the driver also has the ability to restart the negotiation by setting the CSR12<14:12> field to a value of 001.

6.7 Capture Effect—A Value-Added Feature

As a value-added feature, the 21143 provides a complete solution to an unsolved Ethernet and IEEE 802.3 problem referred to as capture effect. This solution is not part of the IEEE 802.3 standard. A device implementing this feature deviates from the IEEE 802.3 standard backoff algorithm. Therefore, this feature is optional and can be enabled or disabled using the CSR6<17> control bit.

6.7.1 What Is Capture Effect?

Consider two stations on the line, station A and station B. Each station has a significant amount of data ready to transmit. Each station is able to satisfy the minimum IPG rules (both from transmit-to-transmit and from receive-to-transmit operations). The following steps show how station A captures the line (Table 6–9):

1. Station A (with data A1) and station B (with data B1) both attempt to transmit simultaneously within a slot time of 51.2 μ s. Each station has an initial collision count set to 0.
2. The stations experience a collision. Both stations increment their collision count to 1.
3. Each station picks a backoff time value that is uniformly distributed from 0 to $(2n)-1$ slots. In this example, station B selects a backoff of 1 (a 50% probability), and station A selects a backoff of 0.
4. Station A successfully transmits its A1 data packet. Station B waits for data A1 to be transmitted before attempting to retransmit data B1.
5. Collision count at station B remains at 1, while collision count at station A is reset to 0.
6. If station A has another packet (data A2) ready to transmit while station B still wants to transmit its packet (data B1), the stations both contend for the line again.

Capture Effect—A Value-Added Feature

7. If these stations collide, the backoff value available for station A is 0 or 1 slots. The backoff value available for station B is 0, 1, 2, or 3 slots because the collision count is now at 2 (station A's collision count is at 1). Station A is more likely to succeed and transmit data A2, while data B1 from station B begins the deferral of completing its backoff interval.
8. It is possible, with this type of behavior between stations, that in the 2-node Ethernet, a station can capture the channel for an unfair amount of time. One station can transmit a significant number of packets back to back, while the other station continues to backoff further and further.
9. This process could continue until station B reaches the maximum number of collisions, 16, while attempting to transmit data B1. At this time, station B would abort data B1. If station B had another packet (data B2), station B would access the line and transmit data B2.

Note: If station A completes the transmitting of a stream of packets during this type of capture, and station B is still in backoff, potentially for a long time, the line is idle for this period of time.

Table 6–9 shows the capture-effect sequence.

Table 6–9 Capture-Effect Sequence

Station A	Line	Station B	Collision A	Count B
Transmit packet A1	Collision	Transmit packet B1	0	0
Backoff 0, 1	—	Backoff 0, 1	1	1
Transmit packet A1	Packet A1	Backoff	0	1
Transmit packet A2	Collision	Transmit packet B1	0	1
Backoff 0, 1	—	Backoff 0, 1, 2, 3	1	2
Transmit packet A2	Packet A2	Backoff	0	2
Transmit packet A3	Collision	Transmit packet B1	0	2
Backoff 0, 1	—	Backoff 0, 1, 2, ... 7	1	3

6.7.2 Resolving Capture Effect

The 21143 generally resolves the capture effect by having the station use, after a successful transmission of a frame by a station, a 2–0 backoff algorithm on the next transmit frame. If the station senses a frame on the network before it attempts to

transmit the next frame, regardless of whether the sensed frame destination address matches the station's source address, the station returns to use the standard truncated binary exponential backoff algorithm (Section 6.3.3.4).

When the station executes the 2–0 backoff algorithm, it always waits for a 2-slot period on the first collision, and for a 0-slot period on the second collision. For retransmission attempts greater than 2, it uses the standard truncated, binary exponential backoff algorithm.

Table 6–10 summarizes the 2–0 backoff algorithm.

Table 6–10 2–0 Backoff Algorithm

Retransmission Attempts	Backoff Period (Number of Slot Times)
$n = 1$	Backoff = 2 slots
$n = 2$	Backoff = 0 slots
$n = 3$ to 15	Backoff = $0 \leq r < 2^k$

$k = \min(n, N)$ and $N = 10$
 $r =$ uniformly distributed random integer

6.7.3 Enhanced Resolution for Capture Effect

The 21143 offers an enhanced resolution for capture effect. The enhancement is made by incorporating a stopped backoff algorithm (with the 2–0 backoff algorithm) to reduce collision while maintaining the key properties of the 2–0 backoff algorithm.

When the enhanced resolution for the capture effect bit is set (CSR6<31>), the 21143 activates the stopped backoff algorithm as follows: in a back-to-back transmit, while in backoff after the first collision ($n=1$, where n is the retransmission attempts), the 21143 stops its backoff timer for the duration when the channel is busy. It continues its backoff timer when the channel is idle. For any other collision cases, the backoff timer is not stopped.

6.8 Jabber and Watchdog Timers

The jabber timer monitors the time of each packet transmission. The watchdog timer monitors the time of each packet reception. If a single packet transmission or reception exceeds a programmable value (Section 3.2.2.18), the jabber and watchdog

Jabber and Watchdog Timers

circuitry automatically disables both the transmit and receive path. The transmit jabber timer provides the jabber function by cutting off transmission and asserting the collision signal to the MAC.

The packet descriptor closes with both transmit jabber timeout (TDES0<14>) and late collision (TDES0<9>) setting if the jabber timer expires on a transmit packet.

The receive watchdog provides the watchdog function by cutting off reception. The packet descriptor closes with the receive watchdog bit (RDES0<4>) set.

Power-Management and Power-Saving Support

This chapter provides an overview of the various power-management specifications and describes the power-management mechanisms supported by the 21143. This chapter also describes the various power-saving modes of the 21143. Throughout this document, the term *power management* is used for mechanisms to control the entire system's power state, while the term *power saving* is used for mechanisms to control the power consumption of the 21143 device itself.

7.1 Overview

The 21143 supports two kinds of power-management mechanisms. The first power-management mechanism is based upon the OnNow initiative and the ACPI specification.¹ This mechanism includes support for the *Advanced Configuration and Power Interface (ACPI) Specification*, the *OnNow Network Device Class Power Management Specification*, and the *PCI Power Management Interface Specification*.

The second power-management mechanism is based upon the remote wake-up-LAN with Magic Packet. The wake-up-LAN mechanism is simpler than the power-management mechanism based upon the OnNow initiative and the ACPI specification. However, power-management based upon the OnNow initiative and the ACPI specification is a requirement of PC 97 and PC 98, and is likely to be more common than the remote wake-up-LAN mechanism.

In addition to the power-management support, the 21143 provides two power-saving modes: sleep mode and snooze mode. In sleep mode, the 21143 consumes minimal power, but most of its functions are not operating. Snooze mode is a dynamic mode in which the device consumes minimal power while in an idle state, and more power

¹This feature is only supported in the 21143-PD and the 21143-TD.

OnNow and ACPI Power-Management Mechanism

when it is active. The 21143 also supports the PCI/CardBus clkrun mechanism for power savings (for information on the PCI/CardBus clkrun mechanism, see Chapter 5).

7.2 OnNow and ACPI Power-Management Mechanism

This section describes the specifications supported by the OnNow initiative and the ACPI specification.¹

7.2.1 Advanced Configuration and Power Interface (ACPI) Specification

The ACPI specification defines a flexible and abstract hardware interface that enables a wide variety of PC systems to implement power-management and thermal-management functions.

The ACPI specification defines power states for each component of the system (system, buses, devices, and so on).

7.2.1.1 PCI Power Management

The *PCI Power Management Interface Specification* is a part of the ACPI specification. This specification defines the behavior and requirements of the PCI bus and each PCI device when put in one of the power-management states defined by the ACPI specification.

Table 7–1 defines each of the power states for a PCI function.

Table 7–1 Power State Definitions

(Sheet 1 of 2)

State	Definition
D0 - Fully On	This state is assumed to be the highest level of power consumption. In this state, the device is completely active and responsive, and is expected to remember all preserved context continuously.
D1	This state operates as a light sleep state. In this state, the PCI clock is running.
D2	This state operates as a deeper sleep state than the D1 state. In this state, the PCI clock can be stopped.

¹This feature is only supported in the 21143–PD and the 21143–TD.

OnNow and ACPI Power-Management Mechanism

Table 7–1 Power State Definitions

(Sheet 2 of 2)

State	Definition
D3 _{hot}	In this state, system power is supplied to the device, but the PCI clock can be stopped. The only context a PCI function in this state should maintain is the power-management event (PME) context.
D3 _{cold}	In this state, system power is removed from the device. The device context is lost. Functions that support power-management events in the D3 _{cold} state must preserve their PME context when transitioning from the D3 _{cold} to the D0 state. Such functions require an auxiliary power source other than the normal Vcc power plane.

The *PCI Power Management Interface Specification* defines how the power-management (wake-up) events are reported by a PCI function. It defines a new power-management register block in the PCI configuration space, and a new active-low PCI pin (PME#) to notify the system of a power-management event. These registers are used by the software to put the device in a power state, and by the PCI function to report the power-management events.

7.2.2 OnNow Network Device Class Power Management Specification

OnNow is a term for a PC that is always powered-up, that appears off, but is capable of responding to users or other requests. OnNow defines the power-management requirements for each device class. The *OnNow Network Device Class Power Management Specification* defines the power-management requirements of a network device.

The *OnNow Network Device Class Power Management Specification* defines the following wake-up events:

- Detection of change in the network link state
- Reception of a network wake-up frame
- Reception of a Magic Packet

A network wake-up frame is typically a frame that is sent by existing network protocols, such as ARP requests or IP frames addressed to the machine. Before putting the network adapter into the wake-up state, the system passes to the adapter's driver a list of sample frames and corresponding byte masks. Each sample frame is an example of a frame that should wake up the system. Each byte mask defines

OnNow and ACPI Power-Management Mechanism

which bytes of the incoming frames should be compared with the corresponding sample frame in order to determine whether or not to accept an incoming frame as a wake-up event.

7.2.3 The 21143 Support for OnNow and ACPI

The 21143 is fully compliant with the *OnNow Network Device Class Power Management Specification Rev 1.0*, the *PCI Power Management Interface Specification Rev 1.0*, and the *ACPI Specification Rev 1.0*.

The 21143 supports all the network device class requirements of the *PC 97 Design Guide* and the *PC 98 Draft Design Guide*.

The 21143 supports all three wake-up events defined in the *OnNow Network Device Class Power Management Specification*.

When the 21143 is put in the D1, D2, or D3 power state, it reads the Magic block information from the serial ROM. The Magic block contains information regarding the Magic Packet IEEE address, password, and the network ports that are connected to the 21143. The 21143 uses the information read from the serial ROM only if the CRC is valid. If the 21143 is put in the present power state when the link fails, or if the link fails while the 21143 is in the D1, D2, or D3 power states, the 21143 starts autosensing and autonegotiations according to the network port information that it has read from the serial ROM, and tries to establish a link. The 21143 can be instructed to generate a wake-up event upon changes in the link status according to Table 7–2. When the link is valid, the 21143 can be instructed to generate wake-up events upon reception of a Magic Packet or a wake-up frame, according to Table 7–2.

In order to stay “virtually connected” to the network while in low-power state, the 21143 monitors the network and wakes the system up on certain protocol-specific frames. The wake-up patterns are provided by software before the 21143 is put in low-power state.

The 21143 wake-up filter supports four programmable filters that allow support of many different receive packet patterns. Specifically, these filters allow support of both IP and IPX protocols, currently the only two protocols targeted to be power manageable. Each filter relates to 31 contiguous bytes in the wake-up frames.

When a frame is received from the network, the 21143 examines its content to determine whether the pattern matches to a wake-up frame. The 21143 first checks the frame’s destination address. Only frames that passed the 21143 address filtering can be accepted as wake-up frames. Each of the four pattern filters can be applied to

OnNow and ACPI Power-Management Mechanism

either unicast frames or multicast frames. To know which bytes of the frame should be checked, in addition to the frame's destination address, the 21143 uses a programmable byte mask and a programmable pattern offset for each of the four supported filters. The pattern's offset defines the location of the first byte that should be checked in the frame. Since the destination address is checked by the 21143 address filtering, the pattern offset is always greater than 12. The byte mask is a 31-bit field that specifies for each of the 31 contiguous bytes with the frame, beginning in the pattern offset, whether or not it should be checked. If bit j in the byte mask is set, byte $offset + j$ in the frame is checked.

The 21143 implements imperfect pattern matching by calculating a CRC-16 on all bytes of the received frames that were specified by the pattern's offset and the byte mask, and comparing it to a programmable precalculated CRC value. The CRC calculation uses the following polynomial:

$$G(x) = x^{16} + x^{15} + x^2 + 1$$

To support wake-up patterns longer than 31 contiguous bytes, or to increase the selectivity of the filter, the 21143 provides the add-previous command. When the add-previous bit is set, the 21143 performs a logical *AND* between the current entry matching signal and the matching signal of the previous filter entry.

The 21143 also implements a global unicast (CSR2-PM<9>) filter. All unicast frames that pass the 21143 address filtering are identified as wake-up frames by the global unicast filter. The global unicast filter functions as the first filter for the add-previous command. If the add-previous command for filter 0 is set, the 21143 performs a logical *AND* between the global unicast matching signal and the filter 0 matching signal.

The 21143 also supports an inverse-mode command. When the inverse-mode bit is set, the 21143 uses its matching signal as a rejection signal, meaning that if a frame does not match this pattern, a wake-up event is generated. In the opposite case, if a frame does match the pattern, a wake-up event is not generated.

Note: Since the 21143 implements imperfect filtering, a CRC value can be matched by more than one pattern. Thus, the inverse-mode command should be used carefully in order to prevent situations in which the group of patterns matched by the CRC contains frames that should also wake up the system.

OnNow and ACPI Power-Management Mechanism

The 21143 filter includes support for VLAN frames. A VLAN frame is identified if the type field has the VLAN type value. A VLAN frame is identical to a non-VLAN frame, except for the 4-byte VLAN header inserted between the source address field and the length/type field. If the 21143 has identified an incoming frame as a VLAN frame, it ignores the VLAN header by automatically incrementing the filter's pattern offset by four bytes for this frame.

The pattern matching parameters including the VLAN parameters can be programmed by writing to CSR1-PM and CSR2-PM, as described in Section 3.2.2.3 and Section 3.2.2.6.

The 21143 supports all the device power states defined in the *OnNow Network Device Class Power Management Specification* and the *PCI Power Management Interface Specification*.

Table 7–2 shows the power-management event capabilities of the 21143.

Table 7–2 Power-Management Event Capabilities

Power State	Link Changed	Magic Packet	Wake-Up Frame
D0 ¹	—	—	—
D1	Yes	Yes	Yes
D2	Yes	Yes	Yes
D3	Yes ²	Yes	Yes
Write access rules	—	—	—

¹ Link changes in the D0 power states are indicated by the software. Magic Packets and wake-up frames are not applicable in the D0 power state.

² In the D3 power state, only link-pass can cause the 21143 to generate a wake-up event, as required by the *OnNow Network Device Class Power Management Specification*.

Upon a wake-up event, the 21143 asserts its **gep<2>/rcv_match/wake** pin if either CPMC<8> or FEMR<4> is set. Func0_HwOptions<9> bit in the serial ROM defines the polarity of the **gep<2>/rcv_match/wake** pin.

The 21143 implements the new power-management register block within the PCI configuration registers as defined by the *PCI Power-Management Interface Specification*. This block contains the power-management capabilities of the 21143 and the power-management control and status.

OnNow and ACPI Power-Management Mechanism

7.2.3.1 Software Procedure for Power States Transitions

Table 7–3 describes the operations expected from the 21143 driver when the 21143 is switched between power states.

Table 7–3 Driver Procedure Upon Moving Between Power States

(Sheet 1 of 2)

From State...	To State...	Procedure
D0	D1/D2/D3	<ol style="list-style-type: none">1. If the address filtering required for wake-up frames is different from what is required in D0, load the 21143 address recognition RAM with the wake-up pattern's address.2. Stop the receive and transmit processes by writing to CSR6.3. Verify that the receive and transmit processes have stopped by polling CSR5.4. If the selected port is AUI/BNC, set the enable link integrity test bit (CSR14<12>) if it has not already been set.5. If the MII management clock bit (CSR9<16>) is set, clear this bit.6. Set the Enable OnNow Registers bit in CSR0.7. Load the wake-up frame filter register block by writing to CSR1-PM.8. Program the requested wake-up events and VLAN parameters and clear the wake-up events bits by writing to CSR2-PM.9. Clear the Enable OnNow Registers bit in CSR0. <p>The 21143 is now ready to be put in the new power state.</p>
D1/D2	D0	<p>After the 21143 is put in D0, the software has to:</p> <ol style="list-style-type: none">1. Reload the 21143 address recognition RAM if the address filtering requirements in D0 are different from what is required for wake-up frames.2. Start the receive and transmit processes by writing to CSR6.

Remote Wake-Up LAN Mode Operation

Table 7–3 Driver Procedure Upon Moving Between Power States

(Sheet 2 of 2)

From State...	To State...	Procedure
D3	D0	After the 21143 is put in D0, the software has to: ¹ <ol style="list-style-type: none">1. Reinitialize the 21143 including media sensing.2. Start the receive and transmit processes by writing to CSR6.

¹The device experiences a hardware reset upon this transition.

7.3 Remote Wake-Up LAN Mode Operation

This section describes the operation for remotely waking up a sleeping workstation using the remote wake-up-LAN and SecureON features of the 21143.

The remote wake-up-LAN mode of operation is a mechanism that uses Advanced Micro Device’s Magic Packet technology to power up a sleeping workstation on the network. This mechanism is accomplished when the 21143 receives a specific packet of information, called a Magic Packet, addressed to the node on the network.

For additional protection, SecureON is an optional security feature that can be added to the Magic Packet that requires a password to power up the sleeping workstation.

When the 21143 is in remote wake-up-LAN mode, main system power can be shut down leaving power only for the 21143 and the PHY chip (hereafter called the auxiliary power condition).

The 21143 performs no network activities while in the remote wake-up-LAN mode of operation—it only monitors the network for receipt of a Magic Packet. If a Magic Packet is addressed to the 21143 on the network, the 21143 sets (high) a special output pin (**gpc2/rcv_match/wake**) to wake up the system.¹ If the SecureON feature has been enabled, the password added to the Magic Packet is also verified prior to waking up the system.

There are two methods for using the remote wake-up-LAN mode of operation:

- With the main system power *off* (auxiliary power condition)
- With the main system power *on* (engineering test mode)

¹For the 21143–PB, 21143–TB, 21143–PC and the 21143–TC, interrupt pin **int_1** is also asserted (low).

7.3.1 Remote Wake-Up-LAN Mode with Main System Power Off

The 21143 and all other components needed for operation of the network interface obtain power from an auxiliary power source.

The 21143 continually senses the main system power status on a single dedicated pin. When the 21143 notices that the main system power has been turned off, it automatically enters remote wake-up-LAN mode. Also, if the auxiliary power supply goes off and then returns (with the main power still off), the 21143 will automatically enter remote wake-up-LAN mode.

While in remote wake-up-LAN mode, the 21143 is in sleep mode except for the remote wake-up-LAN circuits. The 21143 places all PCI output pins in tristate mode and disables all its PCI input drivers. This drastically reduces the 21143 power consumption.

The IEEE address for the Magic Packet and a control word are stored in a dedicated data block within the serial ROM.¹ The control word indicates if the SecureON password feature is enabled and the type of cable autosensing.

When the 21143 enters the remote wake-up-LAN mode of operation, it reads the remote wake-up-LAN data block from the serial ROM. If it detects bad CRC for the block, the 21143 ignores its remote wake-up-LAN functions. If the 21143 detects good CRC, it uses the remote wake-up-LAN IEEE address as a receive address filter. Only Magic Packets with that address or a broadcast address will be checked to meet the wake-up packet requirements. Magic Packets that pass the address filtering (physical or broadcast) will be checked to meet the remote wake-up-LAN data format with the same remote wake-up-LAN IEEE address appearing 16 times. If the SecureON password feature is enabled, the password is verified and the system benefits from an attack-limiter circuit. For more information about the attack-limiter circuit, see Section 7.3.3.

While the 21143 is in remote wake-up-LAN mode, it is totally independent of the software driver. The 21143 implements network port autosensing and autonegotiation (NWAY). It automatically selects the correct serial port for network connection after link failure or auxiliary power loss and return. The 21143, after successfully detecting a Magic Packet, sets (high) a special output pin

¹The remote wake-up-LAN IEEE address might be different from the run-time IEEE address of the workstation.

Remote Wake-Up LAN Mode Operation

(`gpc2/rcv_match/wake`) to wake up the system.¹ The system recognizes the assertion of this pin as a wake-up call. The system will then turn on main system power and issue a hardware reset signal (PCI reset), forcing the 21143 out of remote wake-up-LAN mode.

7.3.2 Remote Wake-Up-LAN Mode with Main System Power On

In the engineering test mode, the main system power remains on. The engineering test mode can be used only with the normal power-saving mode, it cannot be used with the snooze power-saving mode.² System software sets the `FORCE_WAKE_UP_LAN` (FWUL) bit in the 21143's configuration wake-up command register (see Section 3.1.3.4).

When this bit is set, the 21143 is forced to enter remote wake-up-LAN mode and read the remote wake-up-LAN data block from the serial ROM. If it detects bad CRC for the block, the 21143 ignores its remote wake-up-LAN functions. If the 21143 detects good CRC, it uses the remote wake-up-LAN IEEE address as a receive address filter. Only Magic Packets with that address or a broadcast address will be checked to meet the wake-up packet requirements. Magic Packets that pass the address filtering (physical or broadcast) will be checked to meet the remote wake-up-LAN data format with the same remote wake-up-LAN IEEE address appearing 16 times. If the SecureON password feature is enabled, the password is verified and the system benefits from an attack-limiter circuit. For more information about the attack-limiter circuit, see Section 7.3.3.

The remote wake-up-LAN parameters stored in the serial ROM are also implemented as registers in the PCI configuration space. These parameters can be written by the system software while the 21143 is in the remote wake-up-LAN mode if the `LOCK` bit is not set. This allows the system software to override any remote wake-up-LAN parameter read from the serial ROM through the PCI configuration space remote wake-up-LAN registers. These parameters include the remote wake-up-LAN IEEE address, SecureON password, and remote wake-up-LAN command parameters. If the `LOCK` bit is set in the serial ROM's remote wake-up-LAN command word or in the remote wake-up-LAN command register, the remote wake-up-LAN parameters cannot be written by the system software.

¹For the 21143-PB, 21143-TB, 21143-PC, and the 21143-TC, interrupt pin `int_1` is also asserted (low).

²Except for the 21143-PB, 21143-TB, 21143-PC, and the 21143-TC, which can function in the snooze power-saving mode while in the engineering test mode.

Remote Wake-Up LAN Mode Operation

The remote wake-up-LAN command register cannot be read after the 21143 completes a remote wake-up-LAN operation. The remote wake-up-LAN IEEE address and SecureON password can never be read from their registers.

If those registers are accessed while the 21143 is reading the remote wake-up-LAN parameters from the serial ROM, it will send a PCI retry response. This mechanism ensures that remote wake-up-LAN IEEE address and remote wake-up-LAN command override by system software will occur after the 21143 has finished reading the remote wake-up-LAN parameters from the serial ROM.

The 21143, after successfully detecting a Magic Packet, sets (high) a special output pin (**gpc<2>/rcv_match/wake**) to wake up the system.¹ The system recognizes the assertion of this pin as a wake-up call. The 21143 also provides a register status bit that indicates receipt of a Magic Packet. This register bit will not be cleared by any reset (write 1 to clear the bit).

There are two ways to return the 21143 from remote wake-up-LAN mode operation to normal mode operation:

- The system issues a hardware reset signal (PCI reset) forcing the 21143 out of remote wake-up-LAN mode.
- The system software issues a reset command by writing a 1 to CSR0 bit 0 in the 21143. This action is equivalent to a hardware reset.

Note: The 21143 does not process any setup frame that is queued while the 21143 is in remote wake-up-LAN mode.

7.3.3 Invalid Password Limiter

To limit the number of invalid passwords from unauthorized users, the 21143 benefits from a special attack-limiter circuit. This circuit is activated by enabling the SecureON feature. Any Magic Packet with a valid remote wake-up-LAN format, including a good CRC but with an invalid password, is identified as an attack attempt. The 21143 counts every attack and sets CSR15<15> (HCKR) after receiving 16 attack attempts.

¹For the 21143–PB, 21143–TB, 21143–PC, and the 21143–TC, interrupt pin **int_1** is also asserted (low).

Power-Saving Modes

The 21143 also counts all attack attempts within a time interval of T seconds.¹ If there are no attack attempts within the T second interval, this count is reset to zero. If there are four attack attempts within the T second interval, the attack-limiter circuitry locks the reception of further Magic Packets for a duration of T seconds.

7.4 Power-Saving Modes

The 21143 incorporates two different power-saving modes: sleep mode and snooze mode. Setting the Func0_HwOptions<4> (EnableCLKRUN) bit² in the serial ROM provides further reduction in power consumption in the sleep and snooze modes. The following subsections describe these power-saving modes.

7.4.1 Sleep Power-Saving Mode

Sleep mode can be activated when the 21143 is not being used (for example, not connected to the network) and it is important to reduce its power dissipation. While in sleep mode, most of the internal circuits are disabled. This includes the DMA machine, FIFOs, RxM, TxM, SIA, twisted-pair interface, AUI interface, and the general-purpose timer. The PCI section is not affected and access to the 21143 configuration registers remains possible. Access to the 21143 CSRs is not allowed.

To enter sleep mode, the driver must take the following actions:

1. Stop the receive and transmit processes by writing 0 to the CSR6<1> and CSR6<13> fields, respectively. The driver must wait for any previously scheduled frame activity to cease. This is done by polling the transmit process state (CSR5<22:20>) and the receive process state (CSR5<19:17>).
2. In 10BASE-T/AUI mode, reset the SIA by writing 0 to CSR13<0>.
3. Set the CFDD<31> bit.

To exit sleep mode, the driver must take the following actions:

1. Clear the CFDD<31> bit.
2. Wait 10 ms.
3. In 10BASE-T/AUI mode, start the SIA by writing 1 to CSR13<0>.
4. Wait at least 5 μ s.

¹ $T = 20$ seconds in MII/SYM 100-Mb/s mode; $T = 50$ seconds in 10BASE-T/AUI mode; $T = 200$ seconds in MII 10-Mb/s mode.

²The field is only supported in the 21143-PD and the 21143-TD.

5. Start the receive and transmit processes by writing 1 to the CSR6<1> and CSR6<13> fields, respectively.

The 21143 powers up in sleep mode. Sleep mode must be exited before initialization of the 21143.

7.4.2 Snooze Power-Saving Mode

Snooze mode is a dynamic power-saving mode. When the snooze mode bit (CFDD<30>) is set, the 21143 reduces its power dissipation unless one or more of the following conditions is true:

- PCI slave or master access is conducted.
- Transmit process is in the running state.
- Receive process is in the running state but not waiting for a packet.
- Receive FIFO is not empty.
- MAC receive engine is not idle.
- Carrier is sensed.
- General-purpose port interrupt occurred.
- Link pass or link fail occurred.
- Receive interrupt is pending for timer expiration in the interrupt mitigation mechanism.

When none of these conditions is true, the 21143 disables all its internal circuitries except for the PCI interface (not including the Manchester decoder that uses the 100-MHz phases). The 21143 automatically and immediately reenables all its circuitries when at least one of the following occurs:

- PCI slave access is conducted.
- General-purpose port interrupt occurred.
- Carrier is sensed.
- Link pass or link fail occurred.

This results in the 21143 dynamically getting into and out of low-power mode, and overall power dissipation is reduced.

Note: The general-purpose timer and the automatic poll demand functions cannot be used in snooze mode.

Power-Management and Power-Saving Modes

7.5 Power-Management and Power-Saving Modes

The power-management and power-saving features of the 21143 are two independent mechanisms that can operate simultaneously. For example, the 21143 can be programmed to operate in the snooze power-saving mode and still operate in an OnNow power-management machine that generates wake-up events. It is recommended to put the 21143 in the sleep power-saving mode when the Ethernet function is not needed and when the 21143 is not expected to receive or transmit packets or generate wake-up events. For example, if the 21143 is not connected to the LAN, it is recommended to put it in the sleep power-saving mode.

To reduce power consumption, when the 21143 is expected to operate, DIGITAL recommends putting the 21143 into the snooze power-saving mode. For a further reduction in power consumption, while the 21143 is in the sleep or the snooze power-saving mode, DIGITAL recommends setting the Func0_HwOptions<4> (EnableCLKRUN) bit in the serial ROM.

External Ports

This chapter describes the interface and operation of the boot ROM, the MicroWire serial ROM, the general-purpose port, and the network activity LEDs. This chapter also describes how to connect an external register to the boot ROM port.

8.1 Overview

The 21143 provides a boot ROM interface that may be optionally used on the adapter. The boot ROM (expansion ROM) may contain code that can be executed for device-specific initialization and, possibly, a system boot function. During machine boot, the BIOS looks for bootable devices by searching a specific signature (55AA). Once found, the BIOS copies the code from the boot ROM to a shadow RAM in the host memory and executes the code from the RAM. Refer to *PCI BIOS Specification Revision 2.1*.

The boot ROM interface supports:

- 5-V or 12-V flash memory for code upgrade
- 240-ns EEPROM or faster
- Up to 256KB address space

The 21143 provides a software-controlled, serial port interface suitable for MicroWire and other common serial ROM devices. The serial ROM contains the IEEE address and, optionally, other system parameters.

8.2 Boot ROM and Serial ROM Connection

Figure 8–1 shows the connection of a 256KB boot ROM and the serial ROM. The two 9-bit edge trigger latches are used to latch the boot ROM addresses <17:2> and the `oe_1` and `we_1` control signals.

Boot ROM and Serial ROM Connection

Figure 8–1 Boot ROM, Serial ROM, and External Register Connection

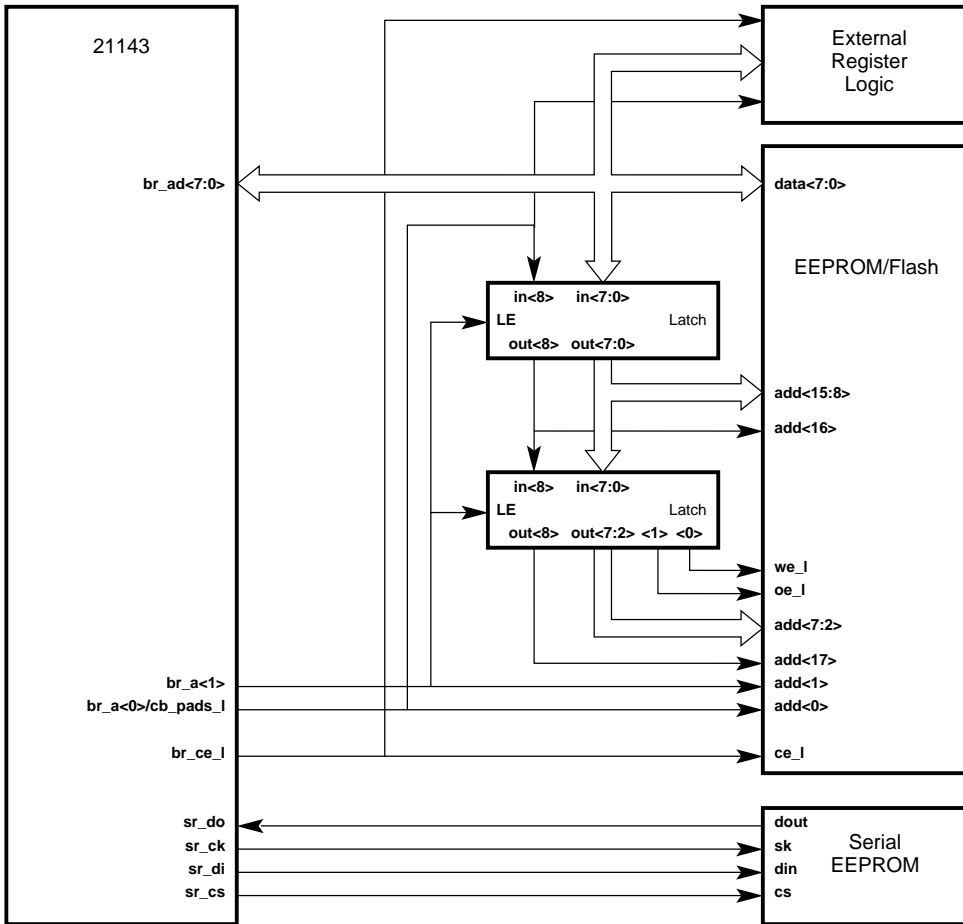

LJ-04830.A14

8.2.1 Boot ROM Size

The 21143 supports various sizes of boot ROM. When the address space of the boot ROM used is 512 bytes or smaller, the 21143 supports one latch on its boot ROM port.¹

¹This feature is only supported in the 21143–PD and the 21143–TD.

The 21143 identifies whether one latch or two latches are connected to its boot ROM port by the Func0_HwOptions<2> bits (SingleBromLatch) in the serial ROM.

8.3 Boot ROM Operations

Access to the boot ROM is done in two ways:

- Byte access (read/write) by using CSR9 and CSR10.
- Dword (32-bit) read access from the PCI expansion ROM address space.

The following sections describe these accesses when two latches are connected to the boot ROM. For each access, the boot ROM must be set to the desired mode (read or write) prior to the actual access for the read or write transaction. For additional information about how this is done, refer to the specific ROM device documentation.

Any mixture between byte access and Dword access is allowed, providing that byte access followed by Dword access will be separated by at least 20 PCI clock cycles. Byte access is not allowed during normal operation. It is typically used for programming the boot ROM.

8.3.1 Byte Read

Figure 8–2 shows the 21143 byte read cycle. It is executed as follows:

1. The host initiates a byte read cycle to the boot ROM by writing the boot ROM offset to CSR10 and by setting a read command in CSR9 (CSR9<14>) and CSR9<12> = 1.
2. The 21143 drives the boot ROM address bits <7:2> and the signals **oe_1** and **we_1** on the **br_ad** lines, drives address bit 17 on the **br_a<0>/cb_pads_1** line, and sets **br_a<1>**. Signal **br_a<1>** is used as a latch_enable to latch the address, **oe_1**, and **we_1** in the upper edge trigger latch.
3. The 21143 clears **br_a<1>**.
4. The 21143 drives the boot ROM address bits <15:8> on the **br_ad** lines, drives address bit 16 on the **br_a<0>/cb_pads_1** line, and sets **br_a<1>**. Address bits <16:8> are latched in the upper edge trigger latch while the previous address bits (17, <7:2>) and the control signals (**oe_1** and **we_1**) are latched in the lower edge trigger latch.
5. The 21143 drives address bits <1:0> on **br_a<1>** and **br_a<0>/cb_pads_1**, respectively, and asserts the **br_ce_1** pin.
6. In response, the boot ROM drives the data on the **br_ad** lines.

Boot ROM Operations

7. The 21143 terminates the byte read cycle by sampling the data, by placing it in CSR9<7:0>, and by deasserting the **br_ce_1** signal.
8. The driver can read the data from CSR9 after at least 20 PCI clock cycles passed since this CSR was previously written. Note that the results of trying to read the data earlier are **UNPREDICTABLE**.

Figure 8–2 Boot ROM Byte Read Cycle

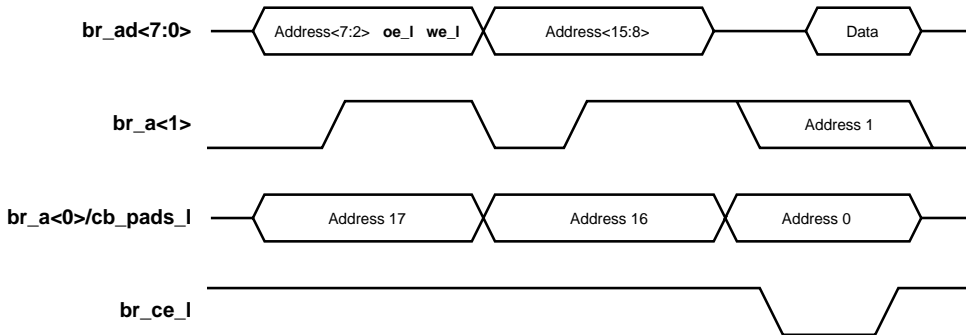

LJ-05204.A14

8.3.2 Byte Write

Before performing a write operation, all the boot ROM entries must be 1. This is achieved by using the erase command.

Figure 8–3 shows the 21143 byte write cycle. It is executed as follows:

1. The host initiates a byte write cycle to the boot ROM by writing the boot ROM offset to CSR10, setting a write command in CSR (CSR9<13> and CSR9<12> = 1), and by writing the data to CSR9<7:0>.
2. The 21143 drives the boot ROM address bits <7:2> and the signals **oe_1** and **we_1** on the **br_ad** lines, drives address bit 17 on the **br_a<0>/cb_pads_1** line, and sets **br_a<1>**. Signal **br_a<1>** is used as a latch_enable to latch the address, **oe_1**, and **we_1** in the upper edge trigger latch.
3. The 21143 clears **br_a<1>**.
4. The 21143 drives the boot ROM address bits <15:8> on the **br_ad** lines, drives address bit 16 on the **br_a<0>/cb_pads_1** line, and sets **br_a<1>**. Address bits <16:8> are latched in the upper edge trigger latch while the previous address bits (<17>, <7:2>) and the control signals (**oe_1** and **we_1**) are latched in the lower edge trigger latch.

5. The 21143 drives address bits <1:0> on **br_a<1>** and **br_a<0>/cb_pads_1**, respectively; drives the data on the **br_ad** lines; and asserts the **br_ce_1** pin.
6. The boot ROM samples the data.
7. The 21143 terminates the byte write cycle by deasserting the **br_ce_1** signal.

Figure 8–3 Boot ROM Byte Write Cycle

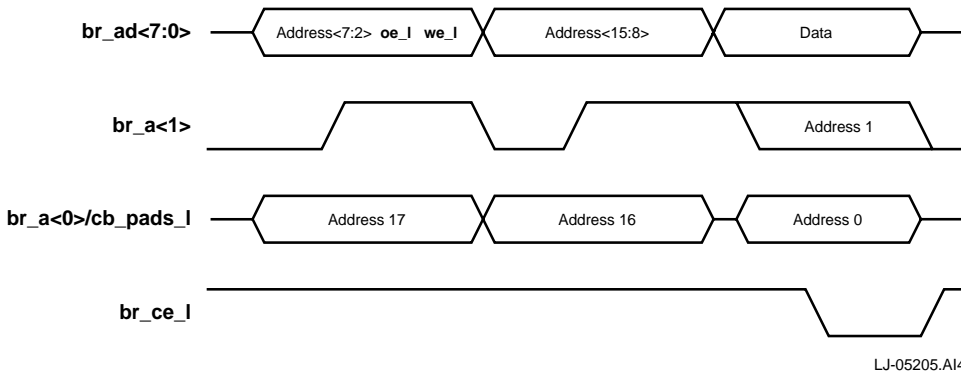

8.3.3 Dword Read

Figure 8–4 shows the Dword read cycle. The host initiates a Dword read cycle by executing a typical read cycle to the expansion ROM address space. The **ad** lines contain the expansion ROM address (base address and offset). Prior to the assertion of the **trdy_1** signal, the 21143 takes the following steps:

1. The 21143 drives the boot ROM address bits <7:2> and the control signals **oe_1** and **we_1** on the **br_ad** lines, drives address bit 17 on the **br_a<0>/cb_pads_1** line, and sets **br_a<1>**. Signal **br_a<1>** is used as a **latch_enable** to latch the address, **oe_1**, and **we_1** in the upper edge trigger latch.
2. The 21143 clears **br_a<1>**.
3. The 21143 drives the boot ROM address bits <15:8> on the **br_ad** lines, drives address bit 16 on the **br_ad<0>** line, and sets **br_a<1>**. Address bits <16:8> are latched in the upper edge trigger latch while the previous address bits (17, <7:2>) and the control signals **oe_1** and **we_1** are latched in the lower edge trigger latch.
4. The 21143 remains **br_a<1>** high, drives **br_a<0>/cb_pads_1** to high, and asserts the **br_ce_1** pin.
5. In response, the boot ROM drives the data on the **br_ad** lines (byte 3).
6. The 21143 samples the data (byte 3).

Serial ROM

7. The 21143 remains **br_a<1>** high, drives **br_a<0>/cb_pads_1** to low, and asserts the **br_ce_1** pin.
8. In response, the boot ROM drives the data on the **br_ad** lines (byte 2).
9. The 21143 samples the data (byte 2).
10. The 21143 drives **br_a<1>** to low, drives **br_a<0>/cb_pads_1** high, and asserts the **br_ce_1** pin.
11. In response, the boot ROM drives the data on the **br_ad** lines (byte 1).
12. The 21143 samples the data (byte 1).
13. The 21143 remains **br_a<1>** low, drives **br_a<0>/cb_pads_1** to low, and asserts the **br_ce_1** pin.
14. In response, the boot ROM drives the data on the **br_ad** lines (byte 0).
15. The 21143 samples the data and deasserts the **br_ce_1** signal.
16. The 21143 assembles the 4 bytes, drives the data on the **ad** lines, and asserts **trdy_1**.

Figure 8–4 Boot ROM Dword Read Cycle

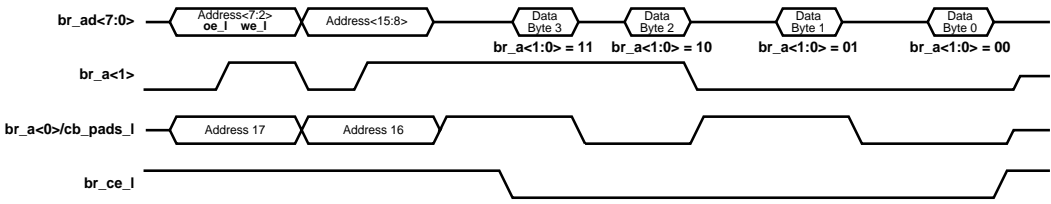

LJ-03977.A14

8.4 Serial ROM

There are four serial ROM interface pins (Table 3–81):

- Serial ROM data out (**sr_do**)
- Serial ROM data in (**sr_di**)
- Serial ROM clock (**sr_ck**)
- Serial ROM chip select (**sr_cs**)

The 21143 supports two sizes of serial ROM, 1Kb and 4Kb.

The serial ROM has three types of information:

- Information that is used by the 21143
- Information that can be used by the 21143 driver
- CIS data

The information that is used by the 21143 is located in the ID block¹ and the Magic block. These blocks are automatically read by the 21143 without software involvement. The ID block is read upon a hardware reset or when the 21143 transitions from the D3 power state to the D0 power state. The Magic block is read when the 21143 transitions from the D0 power state to any other power state, and when the 21143 enters the remote wake-up-LAN mode. The ID block is located at the top of the serial ROM, beginning in address 0; the Magic block is located at the bottom of the serial ROM.

The space in the serial ROM that is between the ID block and the Magic block can be used for driver information and for CIS data. When using the DIGITAL Semiconductor drivers, the area that is immediately after the ID block is used by the driver.

The 21143 driver accesses the serial ROM through CSR9. The access sequences and timing are handled by the software. The serial ROM operations in this method can be read, write, or erase. The read and write operations in this method are described in Section 8.4.1 and Section 8.4.2. The erase operation is handled similarly to the read and write operations.

The serial ROM is mapped into the memory space beginning at offset 200H from the CBMA register.² This feature allows the system software to read the CIS data in a simple memory read operation. For example, when a memory read access to address CBMA + 200H is performed, the 21143 returns the data located in address 0 of the serial ROM. This method can be used only if the CIS data is located in the serial ROM (CCIS<2:0>=2). Write and erase operations are not supported in this method.

¹For the 21143–PB, 21143–TB, 21143–PC, and the 21143–TC, only the first eight bytes of the ID block are loaded by the device.

²This feature is not supported on the 21143–PB, 21143–TB, 21143–PC, and the 21143–TC.

Serial ROM

Access to the serial ROM through memory read is not allowed while an access to the serial ROM through CSR9 is ongoing.

For more information about the serial ROM format including the ID and Magic block, see the *DIGITAL Semiconductor 21X4 Serial ROM Format 4.02* at: <http://ftp.digital.com/pub/Digital/info/semiconductor/networks-and-communications/software/dsc-software-nc.html#support>

8.4.1 Read Operation

Read operations consist of three phases:

1. Command phase—3 bits (binary code of 110)
2. Address phase—6 bits for 256-bit to 1Kb ROMs, 8 bits for 2Kb to 4Kb ROMs.
3. Data phase—16 bits

Figure 8–5 and Figure 8–6 show a typical read cycle that describes the action steps that need to be taken by the driver to execute a read cycle. The timing (listed on the right side of the figures) specifies the minimum time that the driver must wait before advancing to the next action.

During both the address phase in Figure 8–5 and the data phase in Figure 8–6, 1 bit is handled during each phase cycle. Therefore, the address phase should be repeated 6 or 8 times depending on the address length and the data phase should be repeated 16 times. Note that the value DX is the current data bit.

Figure 8–5 Read Cycle (Page 1 of 2)

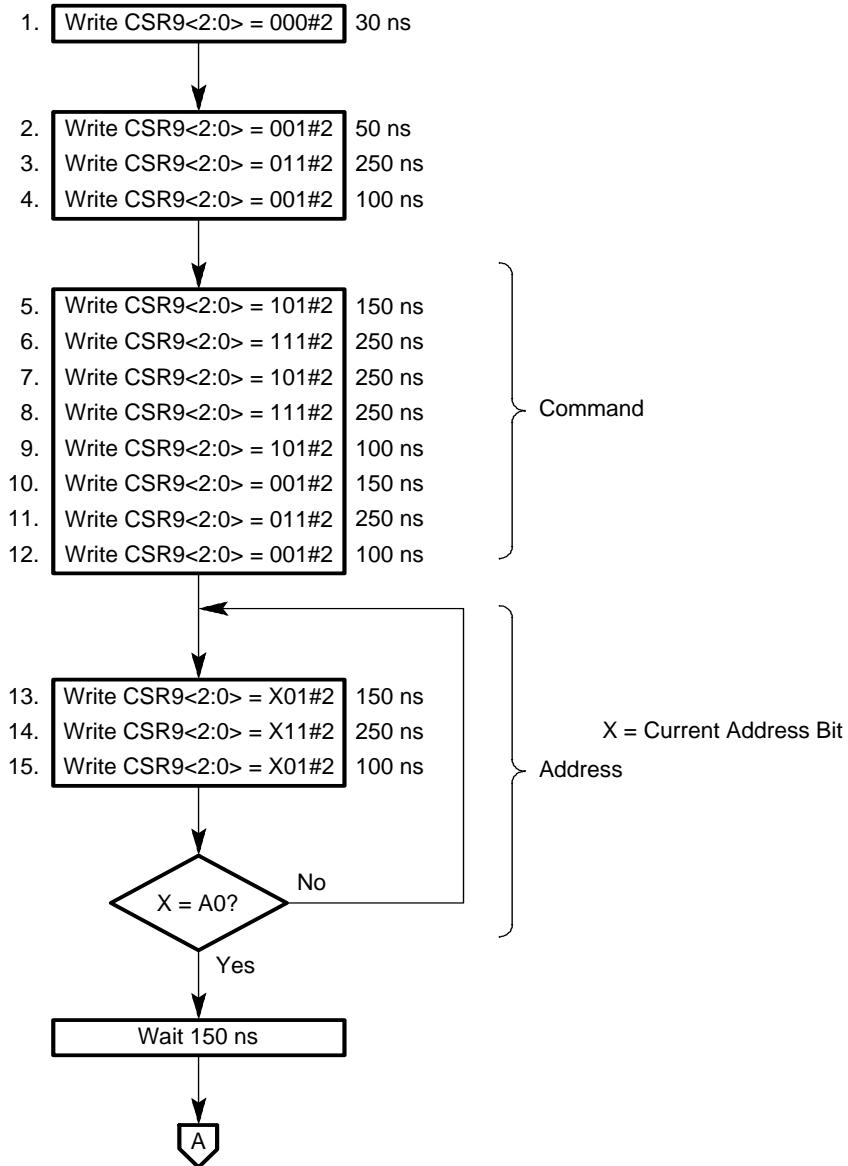

LJ-04049.WMF

Serial ROM

Figure 8–6 Read Cycle (Page 2 of 2)

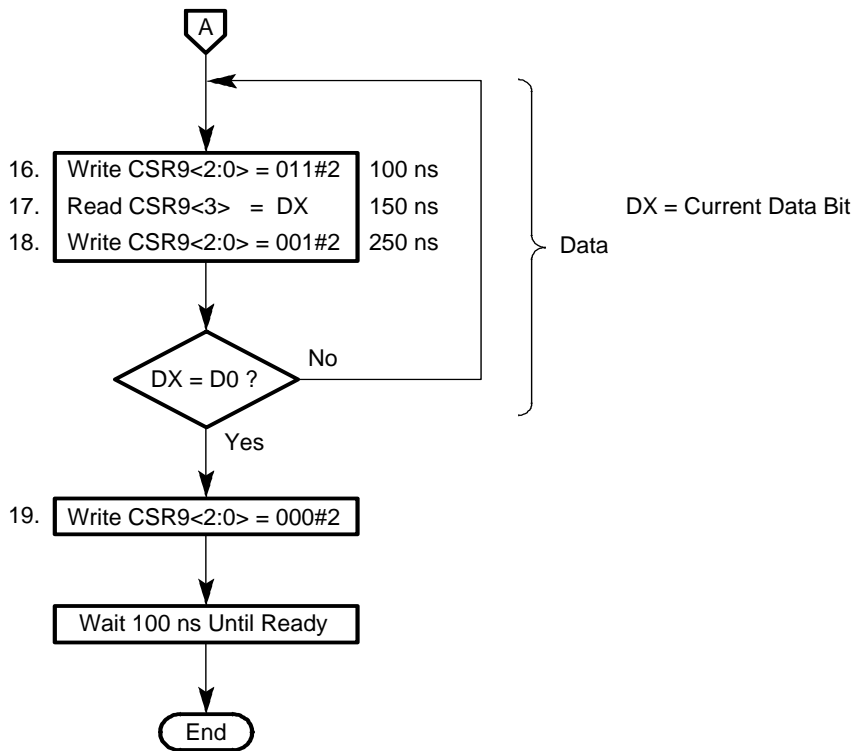

LJ-04050.WMF

Figure 8–7 shows the read operation timing of the address and data.

Figure 8–7 Read Operation



LJ-03994.WMF

8.4.2 Write Operation

Write operations consist of three phases:

1. Command phase—3 bits (binary code of 101)
2. Address phase—6 bits for 256-bit to 1Kb ROMs, 8 bits for 2Kb to 4Kb ROMs.
3. Data phase—16 bits

Figure 8–8 and Figure 8–9 show a typical write cycle that describes the action steps that need to be taken by the driver to execute a write cycle. The timing (listed on the right side of the figures) specifies the minimum time that the driver must wait before advancing to the next action.

During both the address phase in Figure 8–8 and the data phase in Figure 8–9, 1 bit is handled during each phase cycle. Therefore, the address phase should be repeated 6 or 8 times depending on the address length and the data phase should be repeated 16 times.

Serial ROM

Figure 8–8 Write Cycle (Page 1 of 2)

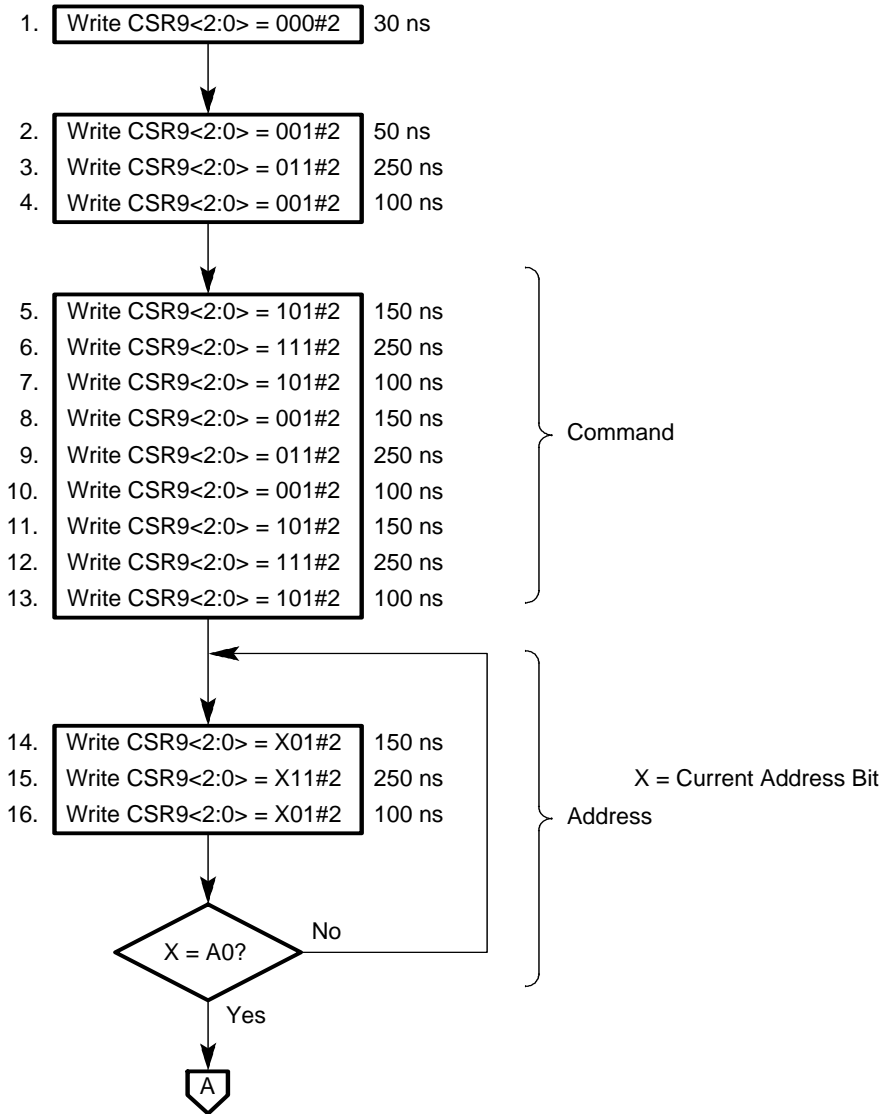

LJ-04052.WMF

Figure 8–9 Write Cycle (Page 2 of 2)

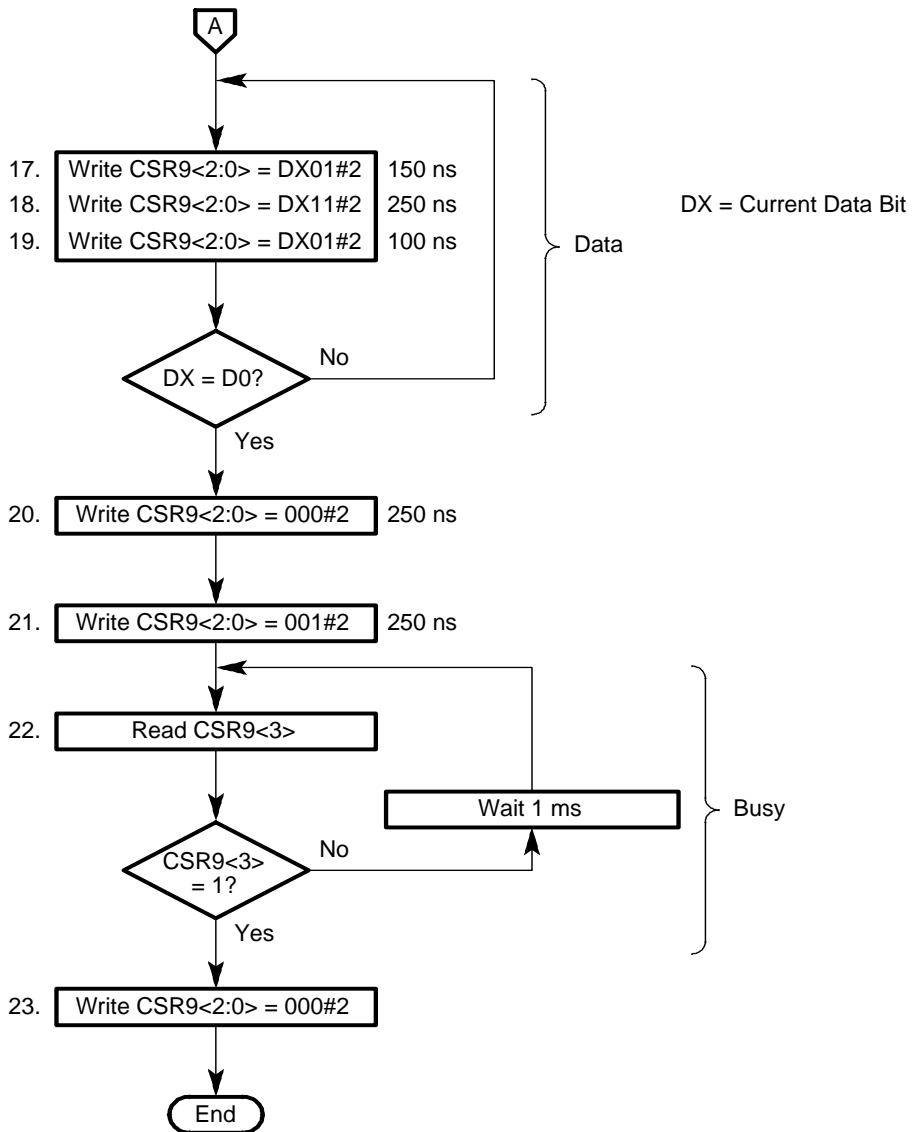

LJ-04053.WMF

External Register Operation

Figure 8–10 shows the write operation timing of the address and data. The time period indicated by **twp** is the actual write cycle time.

Figure 8–10 Write Operation

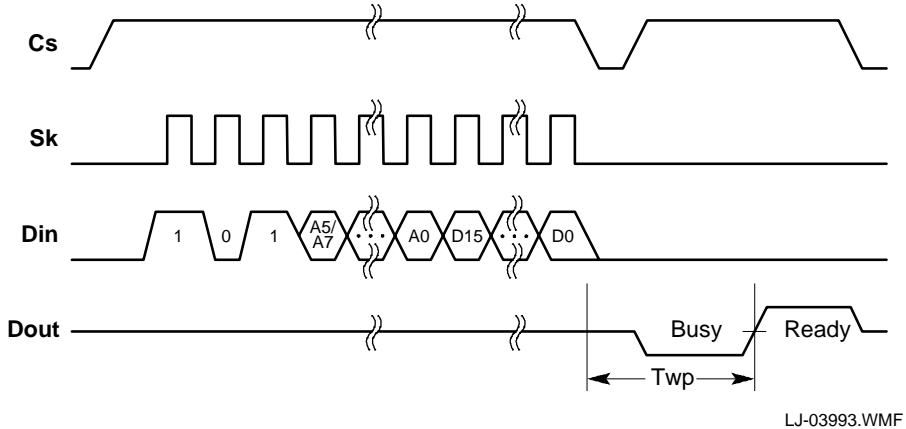

LJ-03993.WMF

8.5 External Register Operation

The 21143 provides the ability to connect an external 8-bit register to the boot ROM port. Figure 8–1 illustrates the signals for this connection. For a detailed description of external register connection, refer to *Using the Digital Semiconductor 21143 Boot ROM, Serial ROM, and External Register: An Application Note*.

Note: CSR10 must be 0 before any external register access is done.

To read from the external register, the driver should set the read command (CSR9<14>) and select the external register (CSR9<10> =1). The 21143 performs the same steps as described in Section 8.3.1. The only differences are that now the 21143 drives 1 on both the **we_1** and **oe_1** boot ROM inputs and drives 0 on **br_a<0>/cb_pads_1**. This, together with the assertion of **br_ce_1**, performs the actual read operation. The data is sampled by the 21143 and is placed in CSR9<7:0>.

Note: Consecutive accesses to the external register should be separated by at least 20 PCI clock cycles. Accessing the serial ROM after access to the external register can be done only after at least 20 PCI clock cycles.

To write to the external register, the driver should set the write command (CSR9<13>), select the external register (CSR9<10>=1), and write the data to CSR9<7:0>. The 21143 performs the same steps as described in Section 8.3.2. The only differences are that now the 21143 drives 1 on both the **we_1** and **oe_1** boot ROM inputs and drives 1 on **br_a<0>/cb_pads_1**. This, together with the assertion of **br_ce_1**, performs the actual write operation.

8.6 General-Purpose Port and LEDs

The 21143 contains a 4-bit port (**gep<3:0>**) that can be used as either as a general-purpose port or for network event LEDs. Each of the four pins can be programmed to be either a general-purpose port pin or for an LED/control pin. Each general-purpose port pin can be programmed to be either an input pin or an output pin. When programmed as an input pin, **gep<1:0>** can generate an interrupt when the pin changes its state either from 1 to 0 or 0 to 1. Refer to Section 3.2.2.18 (CSR15<30:16>) for a detailed programming description. Table 8–1 provides a description of the pin connections for 10BASE2 mode selection and LED indicators.

Table 8–1 Mode Selection and LED Indicator Pin Descriptions

(Sheet 1 of 2)

Signal	Pin Number	Description
au1_bnc	100	This pin is used to enable the external BNC transceiver in 10BASE2 mode.
activ	101	This pin provides the receive and transmit activity indication. A stretcher circuit implemented on this pin enables a direct connection of the pin to the LED. ¹
rcv_match	102	A receive packet passed address recognition.

General-Purpose Port and LEDs

Table 8–1 Mode Selection and LED Indicator Pin Descriptions

(Sheet 2 of 2)

link ²	103	Link and activity indications. This pin provides link indication for the 10BASE-T or 100BASE-TX SYM ports. ³ It can also provide combined link and activity indications. If the MiscHwOptions<0> bit in the serial ROM is cleared, this pin provides only the link indication. If the MiscHwOptions<0> bit in the serial ROM is set, this pin provides both the link and activity indications. In this mode, an LED connected to this pin remains lit when a link is present and there is no activity, and blinks when activity is present.
--------------------------	-----	--

¹For the 21143–PB, 21143–TB, 21143–PC, and the 21143–TC, an external stretcher circuit should be implemented between the **activ** pin and the LED.

²On the 21143–PB, 21143–TB, 21143–PC, and the 21143–TC, this pin was called **10bt_link**.

³For the 21143–PB, 21143–TB, 21143–PC, and the 21143–TC, this pin can only provide link indication for the 10BASE-T port. It cannot provide link or activity indication for the 100BASE-TX SYM port.

A

Joint Test Action Group—Test Logic

This appendix describes the joint test action group (JTAG) test logic and the associated registers (instruction, bypass, and boundary scan).

A.1 General Description

JTAG test logic supports testing, observing, and modifying circuit activity during the components normal operation.

As a PCI device, the 21143 supports the IEEE standard 1149.1 *Test Access Port and Boundary Scan Architecture*. The IEEE 1149.1 standard specifies the rules and permissions that govern the design of the 21143 JTAG test logic support. Inclusion of JTAG test logic allows boundary scan to be used to test both the device and the board where it is installed. The JTAG test logic consists of the following four signals to serially interface within the 21143 (Table 2–1):

tck — JTAG clock

tdi — Test data and instructions in

tdo — Test data and instructions out

tms — Test mode select

Note: If JTAG test logic is not implemented, JTAG pins **tms** and **tdi** should be left unconnected and pin **tck** should be connected to ground.

These test pins operate in the same electrical environment as the 21143 PCI I/O buffers.

Registers

The system vendor is responsible for the design and operation of the 1149.1 serial chains (rings) required in the system. Typically, an 1149.1 ring is created by connecting one device's **tdo** pin to another device's **tdi** pin to create a serial chain of devices. In this application, the 21143 receives the same **tck** and **tms** signals as the other devices. The entire 1149.1 ring is connected to either a motherboard test connector for test purposes or to a resident 1149.1 controller.

Note: To understand the description of the 21143 JTAG test logic in this section, the system designer should be familiar with the IEEE 1149.1 standard.

A.2 Registers

In JTAG test logic design, three registers are implemented through the 21143 pads:

Instruction register

Bypass register

Boundary-scan register

A.2.1 Instruction Register

The 21143 JTAG test logic instruction register is a 3-bit (**IR<2:0>**) scan-type register that is used to direct the JTAG machine to the appropriate operating JTAG mode (Table A–1). Its contents are interpreted as test instructions. The test instructions select the boundary-scan registers for serial transfer of test data by using the **tdi** and **tdo** pins. These instructions also control the operation of the selected test features.

Table A–1 Instruction Register

(Sheet 1 of 2)

IR<2>	IR<1>	IR<0>	Description
0	0	0	EXTEST mode (mandatory instruction) allows testing of the 21143 board-level interconnections. Test data is shifted into the boundary-scan register of the 21143 and then is transferred in parallel to the output pins.
0	0	1	Sample-preload mode (mandatory instruction) allows the 21143 JTAG boundary-scan register to be initialized prior to selecting other instructions such as EXTEST. It is also possible to capture data at system pins while the system is running, and to shift that data out for examination.

Table A–1 Instruction Register

(Sheet 2 of 2)

IR<2>	IR<1>	IR<0>	Description
0	1	0	Reserved.
0	1	1	Reserved.
1	0	0	Reserved.
1	0	1	Tristate mode (optional instruction) allows the 21143 to enter power-saving mode. When this occurs, the PCI and serial ROM port pads are tristated. The MII and SRL ports continue to operate normally without any power reduction.
1	1	0	Continuity mode (optional instruction) allows the 21143 continuity test while in production.
1	1	1	Bypass mode (mandatory instruction) allows the test features on the 21143 JTAG test logic to be bypassed. This instruction selects the bypass register to be connected between tdi and tdo . When the bypass mode is selected, the operation of the test logic has no effect on the operation of the system logic. Bypass mode is selected automatically when power is applied.

A.2.2 Bypass Register

The bypass register is a 1-bit shift register that provides a single-bit serial connection between the **tdi** and **tdo** signals when either no other test data register in the 21143 JTAG test logic registers is selected, or the test logic in the 21143 JTAG is bypassed. When power is applied, JTAG test logic resets and then is set to bypass mode.

A.2.3 Boundary-Scan Register

The JTAG boundary-scan register consists of cells located at the PCI, serial ROM, boot ROM, GEP, and MII port pads. This register provides the ability to perform board-level interconnection tests. It also provides additional control and observation of the 21143 pins during the testing phases. For example, the 21143 boundary-scan register can observe the output enable control signals of the I/O pads: **ad_oe**, **cbe_oe**, and so on. When these signals are programmed to be 1 during EXTEST mode, data is applied to the output from the selected boundary-scan cells.

Registers

The following listing contains the order of the boundary-scan register pads for the 21143–PB, 21143–TB, 21143–PC, and the 21143–TC:

```
tdi          -> int_l      -> rst_l      -> pci_clk    -> gnt_l
-> req_l     -> ad<31:24> -> cbe_oe    -> c_be_l<3> -> idsel
-> ad<23:16> -> c_be_l<2> -> frame_oe  -> frame_l   -> irdy_oe
-> irdy_l    -> trdy_oe    -> trdy_l    -> devsel_oe -> devsel_l
-> stop_oe   -> stop_l     -> perr_oe   -> perr_l    -> serr_l
-> ad_oe     -> par_oe     -> par       -> c_be_l<1> -> ad<15:8>
-> c_be_l<0> -> ad<7:0>   -> inter0    -> br_a<0>   -> br_a<1>
-> br_ad<0>  -> br_ad<1>  -> br_ad<2>  -> br_ad<3>  -> br_ad<4>
-> br_ad<5>  -> br_ad_oe  -> br_ad<6>  -> br_ad<7>  -> gep<0>
-> gep0_oe   -> gep<1>    -> gep1_oe   -> gep<2>    -> gep2_oe
-> gep<3>    -> gep3_oe   -> sr_do     -> sr_di     -> sr_ck
-> inter1    -> mii_crs   -> mii_clsn  -> mii_clsn_oe -> mii_txd<3>
-> mii_txd<2> -> mii_txd<1> -> mii_txd<0> -> mii_txd0_oe -> mii_txen
-> mii_txen_oe -> mii_tclk  -> mii_tclk_oe -> mii_rx_err -> sel10_100_oe
-> mii_rclk  -> mii_rclk_oe -> mii_dv    -> mii_dv_oe  -> mii_rxd<0>
-> mii_rxd0_oe -> mii_rxd<1> -> mii_rxd<2> -> mii_rxd<3> -> mii_mdc
-> mii_mdio  -> mii_mdio_oe-> tdo
```

Note: Internal registers `inter0` and `inter1` are part of the ring but unrelated to the boundary-scan register pads.

The following listing contains the order of the boundary-scan register pads for the 21143-PD and the 21143-TD:

```

tdi          -> int_1      -> rst_1      -> pci_clk    -> gnt_1
-> req_1     -> ad<31:24> -> cbe_oe    -> c_be_1<3> -> idsel
-> ad<23:16> -> c_be_1<2> -> frame_oe  -> frame_1   -> irdy_oe
-> irdy_1    -> trdy_oe    -> trdy_1    -> devsel_oe -> devsel_1
-> stop_oe   -> stop_1     -> perr_oe   -> perr_1    -> serr_1
-> ad_oe     -> par_oe     -> par       -> c_be_1<1> -> ad<15:8>
-> c_be_1<0> -> ad<7:0>    -> inter3    -> inter0
-> br_a<0>/cb_pads_1 -> br_a0_oe -> br_a<1>   -> br_ad<0>
-> br_ad<1>  -> br_ad<2>  -> br_ad<3>  -> br_ad<4>  -> br_ad<5>
-> br_ad_oe  -> br_ad<6>  -> br_ad<7>  -> gep<0>    -> gep0_oe
-> gep<1>    -> gep1_oe   -> gep<2>    -> gep2_oe   -> gep<3>
-> gep3_oe   -> sr_do     -> sr_di     -> sr_ck     -> inter1
-> mii_crs   -> mii_clsn   -> mii_clsn_oe -> mii_txd<3> -> mii_txd<2>
-> mii_txd<1> -> mii_txd<0> -> mii_txd0_oe -> mii_txen   -> mii_txen_oe
-> mii_tclk  -> mii_tclk_oe -> mii_rx_err -> sel10_100_oe
-> mii_rclk  -> mii_rclk_oe -> mii_dv     -> mii_dv_oe  -> mii_rxd<0>
-> mii_rxd0_oe -> mii_rxd<1> -> mii_rxd<2> -> mii_rxd<3> -> mii_mdc
-> mii_mdc_oe -> mii_mdio   -> mii_mdio_oe-> tdo

```

Note: Internal registers inter0, inter1, and inter3 are part of the ring but unrelated to the boundary-scan register pads.

A.2.4 Test Access Port Controller

The test access port (TAP) controller interprets IEEE P1149.1 protocols received on the **tms** pin. The TAP controller generates clocks and control signals to control the operation of the test logic. The TAP controller consists of a state machine and control dispatch logic. The 21143 fully implements the TAP state machine as described in the IEEE P1149.1 standard.

DNA CSMA/CD Counters and Events Support

This appendix describes the 21143 features that support the driver when implementing and reporting the specified counters and events¹. CSMA/CD² specified events can be reported by the driver based on these features.

B.1 CSMA/CD Counters

Table B–1 lists the counters and features.

Table B–1 CSMA/CD Counters

(Sheet 1 of 3)

Counter	21143 Feature
Time since creation counter	Supported by the host driver.
Bytes received	Driver must add the frame length (RDES0<29:16>) fields of all successfully received frames.
Bytes sent	Driver must add the buffer 1 size (TDES1<10:0>) and buffer 2 size (TDES1<21:11>) fields of all successfully transmitted buffers.
Frames received	Driver must count the successfully received frames in the receive descriptor list.
Frames sent	Driver must count the successfully transmitted frames in the transmit descriptor list.

¹As specified in the *DNA Maintenance Operations (MOP) Functional Specification*, Version T.4.0.0, 28 January 1988.

²Carrier-sense multiple access with collision detection.

CSMA/CD Counters

Table B–1 CSMA/CD Counters

(Sheet 2 of 3)

Counter	21143 Feature
Multicast bytes received	Driver must add the frame length (RDES0<29:16>) fields of all successfully received frames with multicast frame (RDES0<10>) set.
Multicast frames received	Driver must count the successfully received frames with multicast frame (RDES0<10>) set.
Frames sent, initially deferred	Driver must count the successfully transmitted frames when deferred (TDES0<0>) is set.
Frames sent, single collision	Driver must count the successfully transmitted frames when the collision count (TDES0<6:3>) is equal to 1.
Frames sent, multiple collisions	Driver must count the successfully transmitted frames when the collision count (TDES0<6:3>) is greater than 1.
Send failure, excessive collisions	Driver must count the transmit descriptors when the excessive collisions (TDES0<8>) bit is set.
Send failure, carrier check failed	Driver must count the transmit descriptors when both late collision (TDES0<9>) and loss of carrier (TDES0<11>) are set.
Send failure, short circuit	There were two successive transmit descriptors when the no_carrier flag (TDES0<10>) is set. This indicates a short circuit.
Send failure, open circuit	There were two successive transmit descriptors when the excessive_collisions flag (TDES0<8>) is set. This indicates an open circuit.
Send failure, remote failure to defer	Flagged as a late collision (TDES0<9>) in the transmit descriptors.
Receive failure, block check error	Driver must count the receive descriptors when CRC error (RDES0<1>) is set and dribbling bit (RDES0<2>) is cleared.
Receive failure, framing error	Driver must count the receive descriptors when both CRC error (RDES0<1>) and dribbling bit (RDES0<2>) are set.
Receive failure, frame too long	Driver must count the receive descriptors when frame too long (RDES0<7>) is set.

Table B–1 CSMA/CD Counters

(Sheet 3 of 3)

Counter	21143 Feature
Unrecognized frame destination	Not applicable.
Data overrun	Driver must count the receive descriptors when (RDES0<0>) is set.
System buffer unavailable	Reported in the missed frame counter CSR8<15:0> (Section 3.2.2.11).
User buffer unavailable	Maintained by the driver.
Collision detect check failed	Driver must count the transmit descriptors when heart-beat fail (TDES0<7>) is set.

C

Hash C Routine

This appendix provides examples of a C routine that generates the hash index for a given Ethernet address. The bit position in the hash table is taken from the CRC32 checksum derived from the first 6 bytes.

There are two C routines that follow: the first is for the little endian architecture and the second is for big endian architecture.

C.1 Little Endian Architecture Hash C Routine

```
#define CRC32_POLY  0xEDB88320UL  /* CRC-32 Poly -- Little Endian*/
#define HASH_BITS  9              /* Number of bits in hash */

unsigned
crc32_mhash(
    unsigned char *mca)
{
    u_int idx, bit, data, crc = 0xFFFFFFFFUL;
    for (idx = 0; idx < 6; idx++)
        for (data = *mca++, bit = 0; bit < 8; bit++, data >>= 1)
            crc = (crc >> 1) ^ (((crc ^ data) & 1) ? CRC32_POLY : 0);
    return crc & ((1 << HASH_BITS) - 1) /* return low bits for hash */
}
```

Big Endian Architecture Hash C Routine

C.2 Big Endian Architecture Hash C Routine

```
#include <stdio>
unsigned HashIndex (char *Address);

main (int argc, char *argv[]) {
    int Index;
    char m[6];
    if (argc < 2) {
        printf("usage: hash xx-xx-xx-xx-xx-xx\n");
        return;
    }
    sscanf(argv[1],"%2X-%2X-%2X-%2X-%2X-%2X",
        &m[0],&m[1],&m[2],
        &m[3],&m[4],&m[5]);

    Index = HashIndex(&m[0]);

    printf("hash_index = %d byte: %d bit: %d\n",
        Index,Index/8,Index%8);
}
unsigned HashIndex (char *Address) {
    unsigned Crc = 0xffffffff;
    unsigned const POLY 0x04c11db6
    unsigned Msb;
    int BytesLength = 6;

    unsigned char CurrentByte;
    unsigned Index;
    int Bit;
    int Shift;

    for (BytesLength=0; BytesLength<6; BytesLength++) {
        CurrentByte = Address[BytesLength];
        for (Bit=0; Bit<8 ; Bit++) {
            Msb = Crc >> 31;
            Crc <<= 1;
```

Big Endian Architecture Hash C Routine

```
    if ( Msb ^ (CurrentByte & 1)) {
        Crc ^= POLY;
        Crc |= 0x00000001;
    }
    CurrentByte >>= 1;
}
}

/* the hash index is given by the upper 9 bits of the CRC
 * taken in decreasing order of significance
 * index<0> = crc<31>
 * index<1> = crc<30>
 * ...
 * index<9> = crc<23>
 */

for (Index=0, Bit=23, Shift=8;
     Shift >= 0;
     Bit++, Shift--) {
    Index |= ( (Crc>>Bit) & 1 ) << Shift );
}

return Index;
}
```

Port Selection Procedure

This appendix describes the port selection procedure for selecting one of the following 21143 ports:

MII

SYM

10BASE-T

AUI

These procedures provide the values to which the CSRs should be programmed, and also the order of programming. These procedures are for mode programming after reset, not for changing modes during operation. This appendix does not list all of the programming options. For additional options, refer to Table 3–96 through Table 3–100.

D.1 MII Port Selection

This section describes the MII port selection for both half-duplex and full-duplex modes.

- Half-duplex mode
 - CSR6<18> = 0
 - CSR13 = 0000H
 - CSR14 = 0000H
 - CSR6<18> = 1
- Full-duplex mode
 - CSR6<18> = 0

SYM Port Selection

CSR13 = 0000H

CSR14 = 0000H

CSR6<9> = 1, CSR6<18> = 1

D.2 SYM Port Selection

This section describes SYM port selection for both half-duplex and full-duplex modes.

- Half-duplex mode

CSR6<18> = 0

CSR13 = 0000H

CSR14 = 0000H

CSR6<18> = 1, CSR6<23> = 1, CSR6<24> = 1

- Full-duplex mode

CSR6<18> = 0

CSR13 = 0000H

CSR14 = 0000H

CSR6<9> = 1, CSR6<18> = 1, CSR6<23> = 1, CSR6<24> = 1

D.3 10BASE-T Port Selection

This section describes the 10BASE-T port selection for half-duplex mode, full-duplex mode, and also with autosensing and autonegotiation.

- Half-duplex mode

CSR6<18> = 0

CSR13 = 0000H

CSR14 = 7F3FH

CSR13 = 0001H

- Full-duplex mode

CSR6<9> = 1, CSR6<18> = 0

CSR13 = 0000H

CSR14 = 7F3DH

CSR13 = 0001H

- Autonegotiation advertising 10BASE-T and 100BASE-TX half-duplex and full-duplex ability

CSR6<18> = 0

CSR13 = 0000H

CSR14 = 3FFFFH

CSR13 = 0001H

D.4 AUI Port Selection

This section describes the AUI port selection for both 10BASE5 and 10BASE2 modes.

- 10BASE5 (AUI) mode

CSR6<18> = 0

CSR13 = 0000H

CSR14 = 0705H

CSR15<3> = 1

CSR13 = 0009H

- 10BASE2 (BNC) mode

CSR6<18> = 0

CSR13 = 0000H

CSR14 = 0705H

CSR15<3> = 0

CSR13 = 0009H

General-Purpose Port and LED Programming

This appendix describes the procedure for programming the general-purpose port. The general-purpose port consists of the following pins:

Pin 100—**gep<0>/aui_bnc**

Pin 101—**gep<1>/activ**

Pin 102—**gep<2>/rcv_match/wake**¹

Pin 103—**gep<3>/link**²

Each pin of the general-purpose port may be programmed for one of the following functions:

Input port with interrupt

Input port without interrupt

Output port

LED/Control

The procedures provide the CSR15 values for programming each of these functions. It uses 21143 pin 103 (**gep<1>/activ**) as an example. The CSR values provided in each line should be written in one CSR access.

¹This pin is called **gep<2>/rcv_match** on the 21143–PB, 21143–TB, 21143–PC, and the 21143–TC.

²This pin is called **gep<3>/10bt_link** on the 21143–PB, 21143–TB, 21143–PC, and the 21143–TC.

Input Port Selection with Interrupt

E.1 Input Port Selection with Interrupt

To select the input port with the interrupt function, write the following values:

First write $CSR15\langle 27 \rangle = 1$, $CSR15\langle 25 \rangle = 1$, $CSR15\langle 21 \rangle = 0$, $CSR15\langle 17 \rangle = 0$

Then write $CSR15\langle 27 \rangle = 0$.

E.2 Input Port Selection Without Interrupt

To select the input port without the interrupt function, write the following values:

First write $CSR15\langle 27 \rangle = 1$, $CSR15\langle 25 \rangle = 0$, $CSR15\langle 21 \rangle = 0$, $CSR15\langle 17 \rangle = 0$

Then write $CSR15\langle 27 \rangle = 0$.

E.3 Output Port Selection

To select the output port function, write the following values:

First write $CSR15\langle 27 \rangle = 1$, $CSR15\langle 21 \rangle = 0$, $CSR15\langle 17 \rangle = 1$

Then write $CSR15\langle 27 \rangle = 0$.

E.4 LED/Control Selection

To select the LED/Control function, write the following values:

First write $CSR15\langle 27 \rangle = 1$, $CSR15\langle 21 \rangle = 1$

Then write $CSR15\langle 27 \rangle = 0$.

F

21143 Magic Packet Format

This appendix describes the 21143 Magic Packet format.

Table F–1 shows the structure of a Magic Packet used in the 21143.

Table F–1 Magic Packet Format for the 21143

Physical/Broadcast Destination Address (A) ¹	
Physical/Broadcast Destination Address (B)	
Physical/Broadcast Destination Address (C)	
Physical/Broadcast Destination Address (D)	
Physical/Broadcast Destination Address (E)	
Physical/Broadcast Destination Address (F)	
Source Node Physical Address (6 Bytes)	
Length/Type (2 Bytes)	
Miscellaneous Data (M Bytes)	
SYNCH1 (FFh)	
SYNCH2 (FFh)	
SYNCH3 (FFh)	
SYNCH4 (FFh)	
SYNCH5 (FFh)	
SYNCH6 (FFh)	
Remote Wake-Up-LAN IEEE Address (A)	Wake-Up Addresses A to F Repeated 16 Times
Remote Wake-Up-LAN IEEE Address (B)	
Remote Wake-Up-LAN IEEE Address (C)	
Remote Wake-Up-LAN IEEE Address (D)	
Remote Wake-Up-LAN IEEE Address (E)	
Remote Wake-Up-LAN IEEE Address (F)	
⋮	
SecureON Password (A) ²	
SecureON Password (B) ²	
SecureON Password (C) ²	
SecureON Password (D) ²	
SecureON Password (E) ²	
SecureON Password (F) ²	
Miscellaneous Data (N Bytes)	
CRC (4 Bytes)	

¹Physical Address = Remote Wake-Up-LAN IEEE Address.

²Must be provided if the SecureON feature is enabled.

Note: The match is performed byte by byte. If one address does not match, the 21143 scans the Magic Packet for another synchronization pattern and repeats the match process. The 21143 makes no assumption of the content of the source node physical address. For example, the source node physical address can start with consecutive FF or have FF at any place in the 6-byte address field.

Filtering Setup Frame Buffer Examples

This appendix provides examples of perfect and imperfect filtering setup frame buffers.

Example G–1 shows a perfect filtering setup buffer (fragment).

Example G–1 Perfect Filtering Buffer

Ethernet addresses to be filtered:

```
A8-09-65-12-34-76 ❶  
09-BC-87-DE-03-15  
.  
.  
.
```

Setup frame buffer fragment while in little endian byte ordering:

```
xxxx09A8 ❷  
xxxx1265  
xxxx7634  
xxxxBC09  
xxxxDE87  
xxxx1503  
.  
.  
.
```

Example G–1 Perfect Filtering Buffer (Cont.)

Setup frame buffer fragment while in big endian byte ordering:

```
A809xxxx ③  
6512xxxx  
3476xxxx  
09BCxxxx  
87DExxxx  
0315xxxx  
.  
.  
.
```

① Displays two Ethernet addresses written according to the Ethernet specification for address display.

② Displays two addresses as they would appear in the buffer in little endian format.

③ Displays two addresses as they would appear in the buffer in big endian format.

Example G–2 shows an imperfect filtering setup frame buffer.

Example G–2 Imperfect Filtering Buffer

Ethernet addresses to be filtered:

```
25-00-25-00-27-00 ①  
A3-C5-62-3F-25-87  
D9-C2-C0-99-0B-82  
7D-48-4D-FD-CC-0A  
E7-C1-96-36-89-DD  
61-CC-28-55-D3-C7  
6B-46-0A-55-2D-7E
```

```
A8-12-34-35-76-08 ②
```

Setup frame buffer while in little endian byte ordering:

```
xxxx0000 ③  
xxxx0000  
xxxx0000  
xxxx1000  
xxxx0000  
xxxx0000  
xxxx0000  
xxxx0000  
xxxx0000
```

Example G-2 Imperfect Filtering Buffer (Cont.)

xxxx0000
xxxx0000
xxxx0000
xxxx4000
xxxx0080
xxxx0000
xxxx0000
xxxx0010
xxxx0000
xxxx0000
xxxx0000
xxxx1000
xxxx0000
xxxx0000
xxxx0000
xxxx0000
xxxx0000
xxxx0000
xxxx0000
xxxx0000
xxxx0000
xxxx0001
xxxx0000
xxxx0000
xxxx0000
xxxx0040
xxxxxxxx
xxxxxxxx
xxxxxxxx
xxxxxxxx
xxxxxxxx
xxxxxxxx
xxxxxxxx

④

xxxx12A8
xxxx3534
xxxx0876
xxxxxxxx
xxxxxxxx
xxxxxxxx
xxxxxxxx
xxxxxxxx
xxxxxxxx
xxxxxxxx
xxxxxxxx

Example G-2 Imperfect Filtering Buffer (Cont.)

Setup frame buffer while in big endian byte ordering:

```
0000xxxxx ⑤  
0000xxxxx  
0000xxxxx  
0010xxxxx  
0000xxxxx  
0000xxxxx  
0000xxxxx  
0000xxxxx  
0000xxxxx  
0000xxxxx  
0000xxxxx  
0040xxxxx  
8000xxxxx  
0000xxxxx  
0000xxxxx  
1000xxxxx  
0000xxxxx  
0000xxxxx  
0000xxxxx  
0010xxxxx  
0000xxxxx  
0000xxxxx  
0000xxxxx  
0000xxxxx  
0000xxxxx  
0000xxxxx  
0000xxxxx  
0100xxxxx  
0000xxxxx  
0000xxxxx  
0000xxxxx  
4000xxxxx  
xxxxxxxxx  
xxxxxxxxx  
xxxxxxxxx  
xxxxxxxxx  
xxxxxxxxx  
xxxxxxxxx  
xxxxxxxxx  
  
A812xxxxx ⑥  
3435xxxxx  
7608xxxxx  
xxxxxxxxx  
xxxxxxxxx
```

Example G-2 Imperfect Filtering Buffer (Cont.)

```
xxxxxxxxx  
xxxxxxxxx  
xxxxxxxxx  
xxxxxxxxx  
xxxxxxxxx  
xxxxxxxxx  
xxxxxxxxx
```

- ❶ Displays Ethernet multicast addresses written according to the Ethernet specification for address display.
- ❷ Displays an Ethernet physical address.
- ❸ Displays the first part of an imperfect filter setup frame buffer, in little endian byte ordering, with set bits for the multicast addresses as in ❶.
- ❹ Displays the second part of the buffer with the physical address as in ❷, in little endian byte ordering.
- ❺ Displays the first part of an imperfect filter setup frame buffer, in big endian byte ordering, with set bits for the multicast addresses as in ❶.
- ❻ Displays the second part of the buffer with the physical address as in ❷, in big endian byte ordering.

Wake-Up Frame Filter Register Block Programming Examples

This appendix provides examples of wake-up frame patterns and how the wake-up frame filter register block should be programmed.

Example H-1 describes the frame patterns for a wake-up with Unicast IP to node AB-00-04-01-D9-FA, Ethernet frame format only

Example H-1 Wake-Up upon Unicast IP, Ethernet Frame Format

Wake-up pattern:

Offset (bytes)	Pattern (hex)	
00	AB 00 04 01 D9 FA	Destination MAC Address (Station Address)
12	08 00	Protocol Type (IP)

Frame data:

```

AB 00 04 01 D9 FA
XX XX XX XX XX XX
08 00
:
:
XX XX

```

Wake-up frame filter register's value:

Filter 0 Byte Mask	00000003	Pattern's bytes: 12, 13
Filter 0 Offset	0C	Offset = 12
Filter 0 Command	01	Unicast, Enable_filter
Filter 0 CRC16	7006	CRC16 (08, 00)

Filter 1, Filter 2, and Filter 3 are not being used.

Wake-up frame filter register block program sequence:

write CSR1-PM	00000003	(Filter 0 Byte Mask)
write CSR1-PM	00000000	(Filter 1 Byte Mask)
write CSR1-PM	00000000	(Filter 2 Byte Mask)
write CSR1-PM	00000000	(Filter 3 Byte Mask)
write CSR1-PM	00000001	(Filter 0-3 Command)
write CSR1-PM	0000000C	(Filter 0-3 Offset)
write CSR1-PM	00007006	(Filter 0-1 CRC16)
write CSR1-PM	00000000	(Filter 2-3 CRC16)

Note: The Destination MAC Address is detected by the 21143 address filtering mechanism and not by the frame filter. The address recognition RAM should be loaded with the AB-00-04-01-D9-FA address (for information about the setting of the address recognition RAM, see Section 4.2.3 and Appendix G).

Example H-2 describes the filter formats for frames.

Example H-2 Filter Formats for Frames

Wake-up upon all various frames that are Unicast IPX to node AB-00-04-01-D9-FA. There are four possible formats for these frames:

- Ethernet frame with Ethernet type
- IEEE 802.3/802.2 SNAP frame
- IEEE 802.3/802.2 SAP frame
- IEEE 802.3/802.2 SAP frame with control

In order to wake up on each one of these formats, all four filters of the 21143 should be used (when each filter is programmed to detect one of these formats).

Ethernet frame with Ethernet type

Wake-up pattern:

Offset (bytes)	Pattern (hex)	
00	AB 00 04 01 D9 FA	Destination MAC Address (Station Address)
12	81 37	Protocol Type (IPX)

Frame data:

```
AB 00 04 01 D9 FA
XX XX XX XX XX XX
81 37
:
:
XX XX
```

Wake-up frame filter register's value:

Filter 0 Byte Mask	00000003	Pattern's bytes: 12, 13
Filter 0 Offset	0C	Offset = 12
Filter 0 Command	01	Unicast, Enable_filter
Filter 0 CRC16	3620	CRC16 (81, 37)

IEEE 802.3/802.2 SNAP frame

Wake-up pattern:

Offset (bytes)	Pattern (hex)	
00	AB 00 04 01 D9 FA	Destination MAC Address (Station Address)
14	AA AA 03 00 00 00 81 37	SAP + Protocol Type (IPX)

Frame data:

```
AB 00 04 01 D9 FA
XX XX XX XX XX XX
XX XX
AA AA 03 00 00 00
81 37
:
:
XX XX
```

Wake-up frame filter register's value:

```
Filter 1 Byte Mask  000000FF  Pattern's bytes: 14..21
Filter 1 Offset      0E      Offset = 14
Filter 1 Command    01      Unicast, Enable_filter
Filter 1 CRC16      B3E1     CRC16 (AA..37)
```

IEEE 802.3/802.2 SAP frame

Wake-up pattern:

Offset (bytes)	Pattern (hex)	
00	AB 00 04 01 D9 FA	Destination MAC Address (Station Address)
14	FF FF	Protocol Type (IPX)

Frame data:

```
AB 00 04 01 D9 FA
XX XX XX XX XX XX
XX XX
FF FF
:
:
XX XX
```

Wake-up frame filter register's value:

Filter 2 Byte Mask	00000003	Pattern's bytes: 14, 15
Filter 2 Offset	0E	Offset = 14
Filter 2 Command	01	Unicast, Enable_filter
Filter 2 CRC16	0000	CRC16 (FF, FF)

IEEE 802.3/802.2 SAP frame with control

Wake-up pattern:

Offset (bytes)	Pattern (hex)	
00	AB 00 04 01 D9 FA	Destination MAC Address (Station Address)
14	E0 E0 03	SAP + Control (IPX)

Frame data:

```
AB 00 04 01 D9 FA
XX XX XX XX XX XX
XX XX
E0 E0 03
:
:
XX XX
```

Wake-up frame filter register's value:

Filter 3 Byte Mask	00000007	Pattern's bytes: 14..16
Filter 3 Offset	0E	Offset = 14
Filter 3 Command	01	Unicast, Enable_filter
Filter 3 CRC16	F779	CRC16 (E0, E0, 03)

Wake-up frame filter register block program sequence:

write CSR1-PM	00000003	(Filter 0 Byte Mask)
write CSR1-PM	000000FF	(Filter 1 Byte Mask)
write CSR1-PM	00000003	(Filter 2 Byte Mask)
write CSR1-PM	00000007	(Filter 3 Byte Mask)
write CSR1-PM	01010101	(Filter 0-3 Command)
write CSR1-PM	0E0E0E0C	(Filter 0-3 Offset)

```
write CSR1-PM B3E13620 (Filter 0-1 CRC16)
write CSR1-PM F7790000 (Filter 2-3 CRC16)
```

Note: The Destination MAC Address is detected by the 21143 address filtering mechanism and not by the frame filter. The address recognition RAM should be loaded with the AB-00-04-01-D9-FA address (for information about the setting of the address recognition RAM, see Section 4.2.3 and Appendix G).

Example H-3 describes the filter formats for frames.

Example H-3 Filter Formats for Frames

Wake-up upon IPv6 neighbor solicitation to node 4037.0.0.0.1.800.200E.8C6C, Ethernet frame only.

The pattern of this frame contains 18 bytes, but they do not reside in 31 contiguous bytes. There are two possibilities to detect frames with this format:

- Use two of the 21143 filters with the add previous command for combining the two filters into one longer pattern matching.
- Use only one filter and check only a part of the pattern.

This example shows how the 21143 wake-up frame filter registers should be programmed for each of the two options.

Wake-up pattern:

Offset (bytes)	Pattern (hex)	
00	FF FF FF FF FF FF	Destination MAC Address (Broadcast)
12	08 00	Protocol Type (IP)
38	FF 02 00 00 00 00 00 00 00 00 00 01 20 0E 8C 6C	IP Destination Address (target's solicited-node multicast address)

Frame data:

```
FF FF FF FF FF FF
XX XX XX XX XX XX
08 00
```

```

XX XX XX XX XX XX
XX XX XX XX XX XX
XX XX XX XX XX XX
XX XX XX XX XX XX
FF 02 00 00 00 00 00
00 00 00 01 20 0E 8C 6C
:
:
XX XX

```

Full pattern matching with add previous:

Wake-up frame filter register's value:

Filter 0 Byte Mask	00000003	Pattern's bytes: 12, 13
Filter 0 Offset	0C	Offset = 12
Filter 0 Command	01	Unicast, Enable_filter
Filter 0 CRC16	7006	CRC16 (08, 00)
Filter 1 Byte Mask	0000FFFF	Pattern's bytes: 38..53
Filter 1 Offset	26	Offset = 38
Filter 1 Command	0D	Multicast, And_Previous, Enable_filter
Filter 1 CRC16	6F0E	CRC16 (FF, 02...8C, 6C)

Wake-up frame filter register block program sequence:

write CSR1-PM	00000003	(Filter 0 Byte Mask)
write CSR1-PM	0000FFFF	(Filter 1 Byte Mask)
write CSR1-PM	00000000	(Filter 2 Byte Mask)
write CSR1-PM	00000000	(Filter 3 Byte Mask)
write CSR1-PM	00000D01	(Filter 0-3 Command)
write CSR1-PM	0000260C	(Filter 0-3 Offset)
write CSR1-PM	6F0E7006	(Filter 0-1 CRC16)
write CSR1-PM	00000000	(Filter 2-3 CRC16)

Partial pattern matching with one filter:

Wake-up frame filter register's value:

Filter 0 Byte Mask	0000FFFF	Pattern's bytes: 38..53
Filter 0 Offset	26	Offset = 38
Filter 0 Command	09	Multicast, Enable_filter
Filter 0 CRC16	6F0E	CRC16 (FF, 02...8C, 6C)

Wake-up frame filter register block program sequence:

write CSR1-PM	0000FFFF	(Filter 0 Byte Mask)
write CSR1-PM	00000000	(Filter 1 Byte Mask)
write CSR1-PM	00000000	(Filter 2 Byte Mask)
write CSR1-PM	00000000	(Filter 3 Byte Mask)
write CSR1-PM	00000009	(Filter 0-3 Command)
write CSR1-PM	00000026	(Filter 0-3 Offset)
write CSR1-PM	00006F0E	(Filter 0-1 CRC16)
write CSR1-PM	00000000	(Filter 2-3 CRC16)

Note: The Destination MAC Address is detected by the 21143 address filtering mechanism and not by the frame filter. The 21143 should be programmed to receive broadcast frame.

Support, Products, and Documentation

To view current product update and errata revision information, please visit the DIGITAL Semiconductor World Wide Web Internet site. You may also visit this website for technical support, a *DIGITAL Semiconductor Product Catalog*, or help deciding which documentation best meets your needs:

<http://www.digital.com/semiconductor>

You can also contact the DIGITAL Semiconductor Information Line or the DIGITAL Semiconductor Customer Technology Center for support.

For documentation and general information:

DIGITAL Semiconductor Information Line

United States and Canada: 1-800-332-2717

Outside North America: 1-510-490-4753

Electronic mail address: semiconductor@digital.com

For technical support, product updates, and errata documentation:

DIGITAL Semiconductor Customer Technology Center

Phone (U.S. and international): 1-978-568-7474

Fax: 1-978-568-6698

Electronic mail address: ctc@hlo.mts.dec.com

DIGITAL Semiconductor Products

To order the DIGITAL Semiconductor 21143 PCI/CardBus 10/100-Mb/s Ethernet LAN Controller and for more information about an Evaluation Board kit, contact your local distributor. The following tables list some of the semiconductor products available from DIGITAL Semiconductor.

Note: The following products and order numbers might have been revised. For the latest versions, contact your local distributor.

Chips	Order Number
DIGITAL Semiconductor 21143 PCI/CardBus 10/100-Mb/s Ethernet LAN Controller (MQFP package)	21143-PD
DIGITAL Semiconductor 21143 PCI/CardBus 10/100-Mb/s Ethernet LAN Controller (LQFP package)	21143-TD
DIGITAL Semiconductor 21540 PCI/CardBus 10/100-Mb/s Ethernet LAN Controller with Modem Interface (TQFP package)	21540-TB

Evaluation board kits include an evaluation board, and can include a complete design kit, an installation kit, or an accessories kit.

Evaluation Board Kits	Order Number
DIGITAL Semiconductor 21143 CardBus Evaluation Board Kit	21A43-02
DIGITAL Semiconductor 21143 PCI Evaluation Board Kit	21A43-04
DIGITAL Semiconductor 21140A 10/100BASE-TX Evaluation Board Kit	21A40-TX

DIGITAL Semiconductor Documentation

The following table lists some of the available DIGITAL Semiconductor documentation. To determine which documents apply to a particular device part number, visit the DIGITAL Semiconductor Documentation Library on DIGITAL Semiconductor's World Wide Web Internet site at:
<http://ftp.digital.com/pub/digital/info/semiconductor/literature/dsc-library.html>

Title	Order Number
DIGITAL Semiconductor 21143 PCI/CardBus 10/100-Mb/s Ethernet LAN Controller Product Brief	EC-QWC2B-TE
DIGITAL Semiconductor 21143 PCI/CardBus 10/100-Mb/s Ethernet LAN Controller Data Sheet	EC-QWC3F-TE
CardBus Guidelines for DIGITAL Semiconductor Ethernet Controllers: An Application Note	EC-QZ1XB-TE
DIGITAL Semiconductor 21143 Connection to the Network Using MII-based Physical Layer Devices: An Application Note	EC-QXY7A-TE
Using the DIGITAL Semiconductor 21143 with External Flash ROM, Serial ROM, and External Register: An Application Note	EC-QYZ1B-TE
Power Management in DIGITAL Semiconductor Ethernet LAN Controllers: An Application Note	EC-R96DA-TE
DIGITAL Semiconductor 21140A PCI Fast Ethernet LAN Controller Data Sheet	EC-QN7PF-TE
DIGITAL Semiconductor 21140A PCI Fast Ethernet LAN Controller Hardware Reference Manual	EC-QN7NF-TE
DIGITAL Semiconductor 21140A PCI Fast Ethernet LAN Controller Product Brief	EC-QN7MB-TE
DIGITAL Semiconductor 21540 PCI/CardBus 10/100-Mb/s Ethernet LAN Controller with Modem Interface Product Brief	EC-R77QA-TE

Third-Party Documentation

You can order the following third-party documentation directly from the vendor.

Title	Vendor
PCI Local Bus Specification, Revision 2.1	PCI Special Interest Group
PCI Multimedia Design Guide, Revision 1.0	U.S. 1-800-433-5177
PCI System Design Guide	International 1-503-797-4207
PCI-to-PCI Bridge Architecture Specification, Revision 1.0	Fax 1-503-234-6762
PCI BIOS Specification, Revision 2.1	
Institute of Electrical and Electronics Engineers (IEEE) 802.3 and 1149.1	The Institute of Electrical and Electronics Engineers, Inc.
	U.S. 1-800-701-4333
	International 1-908-981-0060
	Fax 1-908-981-9667

Numerics

- 100BASE-FX
 - implementation, 6–2
- 100BASE-T
 - definition, 6–1
- 100BASE-T4
 - implementation, 6–1
- 100BASE-TX
 - implementation, 6–2
- 100BASE-X
 - implementation, 6–1
- 10BASE-T
 - functions of, 6–5
 - link integrity test, 6–9
 - port select, 3–61, D–2
- 10-MHz clock
 - options, 6–6

A

- ACPI, 7–1, 7–4
- Address filtering, 3–60, 3–63, 3–88, 7–10,
 - H–2
 - bits, 4–21
 - caution, 4–30
 - driver procedure, 7–7
 - frame processing, 4–31
 - hash, 4–18
 - hash only, 4–18
 - ignore destination address, 3–60
 - imperfect, 3–63
 - imperfect mode, 3–62
 - MAC address detected, H–6, H–8

- packet passed, 3–88
- pass bad frame mode, 3–62
- pass Magic Packets, 7–9
- pass unicast frames, 7–5
- Alignment
 - error description, 6–20
- Arbitration
 - bus, 3–37
 - scheme, 4–27
 - timing, 5–7
- Attack-limiter circuit, 7–11
- AUI
 - functions of, 6–5
 - port select, 3–61, D–3
- Autonegotiation
 - arbitration states, 3–79
- Autopolarity detector
 - purpose of, 6–7
- Auxiliary power, 2–13, 7–3, 7–8

B

- Boot ROM
 - byte read, 8–3
 - byte write, 8–4
 - Dword read, 8–5
 - interface, 3–72
 - overview, 8–1
 - pointer, 3–75
 - select, 3–73
- Boot ROM programming address register
 - See* CSR10
- Boot ROM, serial ROM, and MII management
 - register
 - See* CSR9
- Burst length, 3–37

Bus
 commands, 5–2
 error bits, 3–57
 runt frames, 1–1
 unsupported transactions, 5–3
Bus arbitration, 3–37, 3–61, 5–6, 5–7
Bus master, 5–1
 enabling, 3–9
 operations, 5–6
Bus mode register
 See CSR0
Bus slave, 5–1
 operations, 5–2
Byte ordering
 big endian, 3–37
 little endian, 3–37

C

Cache, 3–37, 3–39
Capture effect
 2–0 backoff algorithm, 6–27
 definition, 6–25
 enable, 3–61
 example, 6–25
 resolution, 6–26
 sequence, 6–26
 special enable, 3–59
Carrier-sense multiple access with collision
 detection
 See CSMA/CD
CBER, 3–17
 mapping, 3–17
 ROM enable bit, 3–17, 3–18
CBIO, 3–12
 address, 3–13
CBMA, 3–13
 address, 3–14
CCIS, 3–14
 ROM image, 3–15
 space offset, 3–15
CFCS, 3–7
CFDD, 3–24
CFID, 3–6
CFIT, 3–19
CFLT, 3–11
CFRV, 3–10
Command and status configuration register
 See CFCS
Configuration base I/O address register
 See CBIO
Configuration base memory address register
 See CBMA
Configuration card information structure
 register
 See CCIS
Configuration driver area register
 See CFDD
Configuration ID register
 See CFID
Configuration interrupt register
 See CFI
Configuration latency timer register
 See CFLT
Configuration registers
 enhanced, 3–4
 mapping, 3–4
Configuration revision register
 See CFRV
Control and status register
 See CSR
Conventions, xx
CRC, 2–10, 3–45
 CRC-16, 3–44
 cyclic redundancy check error, 4–9
 disable padding effect, 4–17
 disable to end of frame, 4–17
 error, 6–19
 Ethernet cyclic redundancy check, 4–23
 hacker, 3–90
 See also Frame check sequence
 wake-up frame filter register structure,
 3–41
CSMA/CD
 counters, B–1
CSR

- access to, 3–33
- autoconfiguration, 3–81
- mapping, 3–34
- CSR0, 3–35
- CSR1, 3–39
- CSR10, 3–75
- CSR11, 3–76
 - expired, 3–54
 - value, 3–77
- CSR12, 3–78
- CSR13, 3–81
- CSR14, 3–82
- CSR15, 3–87
- CSR2, 3–46
- CSR3, 3–49
- CSR4, 3–49
- CSR5, 3–51
- CSR6, 3–58
- CSR7, 3–67
- CSR8, 3–71
- CSR9, 3–72
- CWUA1, 3–27
- CWUC, 3–21, 3–23, 3–31
- Cyclic redundancy check
 - See* CRC

D

- Data communications, 4–1
- Descriptor
 - error, 6–20
 - list addresses, 3–49
 - missed frame counter, 3–71
 - skip length, 3–37
- Descriptor list address registers
 - See* CSR3 and CSR4
- Destination address bit 1, 6–18
- Device select
 - timing, 3–8
- Disconnect, 2–12, 3–7, 3–25, 5–11, 5–13, 5–16, 5–17
- DMA
 - programmable burst length, 3–37

- Dribbling bit, 4–8, 6–19

Duplex

- full, 3–62, 3–83, 3–92, 6–1, 6–9, 6–22, 6–23, 6–24
- half, 3–62, 3–83, 3–84, 4–27, 6–9, 6–23, 6–24

E

- Electrical specifications, 4–1

- End of ring, 4–10, 4–17

- Endian, 2–4, 3–36, 3–37

Error

- system, 3–8

Ethernet

- frame format, 6–10

- imperfect filtering, 6–12

- inverse filtering, 6–12

- perfect filtering, 6–12

- promiscuous reception, 6–12

- receive addresses, 6–12

- Expansion ROM base address register

- See* CBER

External register

- operation, 8–14

- select, 3–74

F

Fast transactions

- back-to-back, 3–8

Frame check sequence

- computation, 6–11

Frame format

- description, 6–10

Frame too long

- description, 6–20

- Full-duplex mode, 3–62

- Full-duplex operations, 6–22

G

General-purpose

- port and LEDs, 8–15

General-purpose timer register
See CSR11

H

Half/full-duplex autonegotiation
description, 6–23

Hardware reset

- after, 6–9
- ID block, 8–7
- initiate, 4–25
- lock state, 3–31
- parity checking, 3–9
- port select, 3–61
- power state, 3–3, 7–8
- signal issued, 7–10, 7–11
- sleep mode, 3–25

Hash, 4–23, 4–24

- algorithm, 6–12
- filtering, 4–18
- filtering modes, 3–65
- only filtering, 3–62, 4–18
- only receive filtering, 4–31
- perfect, 3–63, 4–31

Hash C routine

- example, C–1

Heartbeat, 3–60, 3–62, 3–84, 4–14, 4–15
collision pulse fail, 4–15

Host communication

- data buffers, 4–2
- descriptor lists, 4–1
- descriptor ring and chain structures, 4–3
- receive descriptor format, 4–4
- transmit descriptor format, 4–12

I

I/O space

- access to, 3–9

ID

- device, 3–6
- manufacturer, 3–6

IEEE 802.3

signals, 6–2

Input port selection

- with interrupt, E–2
- without interrupt, E–2

Interpacket gap

See IPG

Interrupt

- ETI, 3–55
- mitigation, 3–34, 4–29, 5–20, 7–13

Interrupt enable register

See CSR7

Interrupts

- abnormal, 3–54
- early receive, 3–54
- early receive enable, 3–68
- enabling, 3–67
- multiple events, 4–28
- normal, 3–53
- pin definition, 3–19

IPG

IPS1

- duration, 6–14

IPS2

- duration, 6–14

J

Jabber timeout, 3–54, 4–36, 6–28

Jabber timer

- purpose of, 6–27

Joint test action group

See JTAG, A–1

JTAG

- description, A–1
- registers, A–2
 - boundary scan, A–3
 - bypass, A–3
 - instruction, A–2

L

Late collision, 4–8, 4–14, 6–15, 6–19, 6–28

Latency

- counter, 4–30
- high bus systems, 6–13
- low bus systems, 6–13
- timer, 3–4, 3–11, 3–12

Latency timer

- count, 3–12

LED/control selection, E–2

Link

- fail state, 3–80
- pass state, 3–80
- preventing false detection, 3–90

Link change, 2–14, 3–48, 4–28

- detected, 3–48
- event detected, 5–20
- in power state, 7–6

Link fail

- test fail, 4–15

Loopback modes, 6–20

- driver enters, 6–21
- driver exits, 6–22
- external, 6–21
- internal, 6–20

Loopback operation mode, 3–65

M

MAC, 6–9 to 6–16

Magic Packet, 3–28, 3–32, 7–3, 7–4

- change in power state, 7–6
- detected, 2–7
- enable, 3–48
- overview, 7–8
- received, 3–48
- security, *See* SecureON
- pass address filtering, 7–9

Manchester

- decoder, 6–6
- encoder, 6–6

Master abort, 3–8, 3–57, 5–13, 5–14

Media access control

- See* MAC

Media-independent interface

- See* MII

Memory space

- access to, 3–7, 3–9

Memory write and invalidate enable command, 3–9

MII

- characteristics, 6–2
- error, 4–8
- location, 6–1
- management, 3–72
- port, 6–1
- port select, 3–61
- port selection, D–1
- signals, 6–2

MII/SYM

- operating modes, 6–4

Missed frame counter register

See CSR8

Modes

- descriptor byte ordering, 3–36
- filtering, 3–65
- force collision, 3–61
- imperfect address filtering, 3–62
- inverse filtering, 3–62
- MII programming, 3–92
- pass bad frames, 3–62
- perfect address filtering, 3–63
- promiscuous, 3–62
- receiver operating, 3–82
- SIA programming, 3–91, 3–92, 3–97, 3–99, 3–100, 3–101
- sleep, 3–25
- transmitter operating, 3–82

O

Operation mode register

See CSR6

Output port selection, E–2

P

Packets

- IPG, 6–22

Parity
 disable checking, 3–9
 error detection, 3–8
 generation, 5–18
 report, 5–18
 software reset, 3–57
 status, 3–8
Parking, 5–19
Password protection
 See SecureON
PCI
 purpose, 5–1
PCS
 implementation, 6–1
Peripheral component interconnect
 See PCI
Physical coding sublayer
 See PCS
Physical layer medium dependent
 See PMD
Physical medium attachment
 See PMA
Pinout diagram, 2–1
PMA, 6–1
PMD, 6–2
Port
 data rate, 3–64
Power-saving modes, 4–26
 sleep, 3–25
 snooze, 3–25
Preamble recognition sequence, 6–17

R

RDES0, 4–5
RDES1, 4–9
RDES2, 4–10
RDES3, 4–11
Read cycle
 configuration, 5–5
 memory, 5–8
 slave, 5–3
Receive
 all packets, 3–60
 buffer 1 address, 4–11
 buffer 2 address, 4–11
 data buffer 1
 byte size, 4–10
 data buffer 2
 byte size, 4–10
 data type, 4–7
 descriptor status validity, 4–12
 DMA conditions, 4–26
 end of ring, 4–10
 error summary, 4–6
 first descriptor, 4–7
 frame length, 4–6
 frame too long, 4–7
 frame type, 4–8
 last descriptor, 4–7
 multicast frame, 4–7
 OWN bit, 4–6
 process state, 3–58
 second address chained, 4–10
 start of list, 3–49
Receive descriptor 0
 See RDES0
Receive descriptor 1
 See RDES1
Receive descriptor 2
 See RDES2
Receive descriptor 3
 See RDES3
Receive descriptors, 4–3 to 4–12
 See also specific receive descriptor entries
Receive poll demand register
 See CSR2
Receive process, 4–31 to 4–33
 buffer unavailable, 3–55
 descriptor acquisition, 4–31
 frame processing, 4–31
 start, stop, 3–63
 state transitions, 4–33
 when suspended, 4–32
 window, 4–27
Receiving operation, 6–16 to 6–20

- address matching, 6–18
- data polarity, 3–83
- frame condition, 6–19
- frame decapsulation, 6–18
- initiation, 6–16
- preamble processing, 6–16
- terminating, 6–19

Registers, 3–1 to 3–95

See also specific register entries

Remote wake-up-LAN, 3–90

- CSR15 change
 - HCKR, Hacker, 3–90
 - RMP, Received Magic Packet, 3–90

Reset

- hardware, 4–25
- SIA, 3–81
- software, 4–25

Revision number, 3–10

Runt frame

- size, 6–20

S

SecureON

- overview, 7–8

Security

See SecureON

Serial port autosensing

- description, 6–8

Serial ROM

- interface, 3–72
- overview, 8–1
- read operation, 8–8
- select, 3–73
- write operation, 8–11

Setup frame

- imperfect filtering format, 4–23
- perfect filtering format, 4–22
- size, 4–20

SIA

- driver enable, 3–85

Signal quality

- heartbeat, 3–84

Sleep mode, 3–25, 7–12

Smart squelch

- description of, 6–7

Snooze mode, 3–25, 7–13

SOP0, 3–29

SOP1, 3–30

Specifications

- electrical, 4–1

SSID, 3–16

- subsystem ID, 3–16
- subsystem vendor ID, 3–16

Startup procedure, 4–30

Status

- CSR5, 3–52

Status register

See CSR5

STP, 6–2

Subsystem ID register

See SSID

SYM

- port selection, D–2

System error

- enabling, 3–8

T

Target disconnect

- termination, 5–16

Target retry

- data transaction, 5–17

TDES0, 4–13

TDES1, 4–16

TDES2, 4–19

TDES3, 4–19

Terminations

- master abort, 3–8
- master-initiated, 5–13
- memory-controller, 5–13
- slave-initiated, 5–11
- target abort, 3–8

TP

See Twisted-pair

Transmit

- automatic polling, 3–38
- buffer 1 address, 4–19
- buffer 2 address, 4–19
- collision counter, 4–15
- CRC disable, 4–17
- data buffer 2
 - byte size, 4–17
- data buffer1
 - byte size, 4–17
- defer, 4–15
- descriptor status validity, 4–20
- DMA conditions, 4–26
- end of ring, 4–17
- error summary, 4–14
- filtering types, 4–18
- first segment, 4–16
- interrupt on completion, 4–16
- last segment, 4–16
- OWN bit, 4–14
- padding disable, 4–17
- process state, 3–57
- second address chained, 4–17
- start of list, 3–50
- threshold, 3–64
- Transmit descriptor 0
 - See* TDES0
- Transmit descriptor 1
 - See* TDES1
- Transmit descriptor 2
 - See* TDES2
- Transmit descriptor 3
 - See* TDES3
- Transmit descriptors, 4–12 to 4–20
 - See also specific transmit descriptor entries*
- Transmit jabber timer
 - timeout, 3–55
- Transmit poll demand register
 - See* CSR1
- Transmit process, 4–34 to 4–37
 - buffer unavailable, 3–56
 - frame processing, 4–34
 - polling suspended, 4–35
 - state transitions, 4–36

- window, 4–27
- Transmit threshold
 - 10 Mb/s or 100 Mb/s, 3–60
- Transmitting operation, 6–13 to 6–16
 - collision, 6–14
 - initial deferral, 6–14
 - initiation, 6–13
 - parameters, 6–16
 - termination, 6–15
- Twisted-pair
 - compensation behavior, 3–86
 - interface, 6–6

W

- Wake-up-LAN
 - modes of operation, 7–8
 - network activities, 7–8
 - packet format, F–1
- Wake-up-LAN configuration registers
 - CWUA0, 3–26
 - CWUC, 3–20, 3–23, 3–30
- Watchdog timer
 - line status, 3–55
 - purpose of, 6–27
 - receive, 4–8
- Write cycle
 - memory, 5–9
 - slave, 5–4